

MUD / MUS series



2/2 WAY N.C., N.O. PLUNGER / PISTON TYPE SOLENOID VALVE

mindman

2-WAY normally closed / normally open solenoid valve.
Available fluid: Water, air, steam, light oil, gas & vacuum.



2/2 N.C.

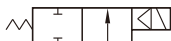

2/2 N.O.

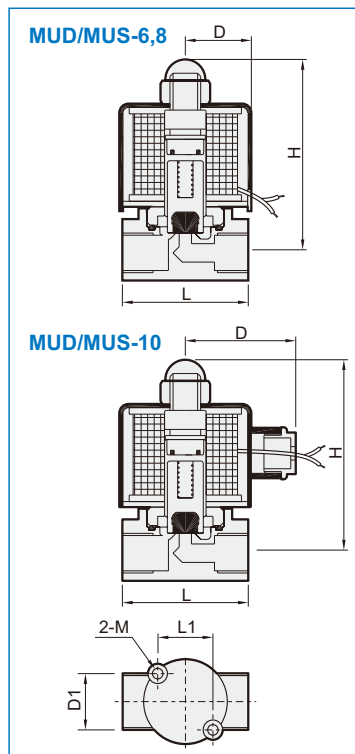

Specification

- Small size & easy assembly.
- Other voltage of AC/DC available when required.
- Installation: Mountable in any position without affecting operation.
- Viton(130°C), Silicon(130°C), PTFE (185°C).
- AC Voltage tolerance: ±10%.
DC Voltage tolerance: ±1%.

Material

Parts name	Material
Body	Forge brass
Coil	Special copper wire (H)
Tube	Stainless steel
Spring	Stainless steel
Fixed steel	Special st. steel
Plug	NBR, Viton, Silicon, PTFE
Disc	NBR, PTFE

Caution

- Pipes must be washed neat and clean before fitted.
- A Y-STRAINER has to be installed in the front of solenoid valve, that is best for long life.
- Prohibition vertical operation.

Not for fluid of

- Liquid when heat, solid when cool.
- Corrosive fluid.
- Viscosity over 20 cst.

Order example

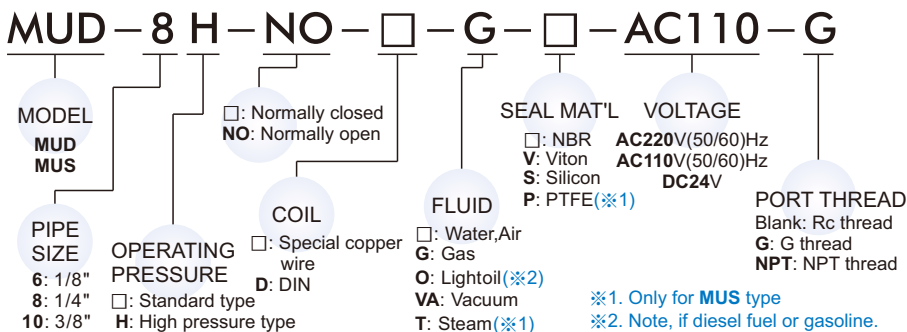

Model	DIN	Pipe size	Cv	Orifice (mm)	Fluid temp	Max. operating pressure diff. MPa					Dimensions (mm)						Weight (kg)	
						Water	Air	Steam	Light oil/ Gas	Vacuum	L	H	D	L1	D1	M		
NC	MUD-6	Rc1/8"	0.23	2.5	-5~+80°C	0~0.7	0~0.7	—	—	0~10 ⁻³ Torr	41	63	21	23	19.3	M4×0.7	0.3	
	MUD-8	Rc1/4"	0.23	2.5	-5~+80°C	0~0.7	0~0.7	—	—	0~10 ⁻³ Torr	41	63	21	23	19.3	M4×0.7	0.3	
	MUD-8	Rc1/4"	0.58	4	-5~+80°C	0~0.3	0~0.3	—	—	0~10 ⁻³ Torr	41	63	21	23	19.3	M4×0.7	0.3	
	MUD-8	Rc1/4"	0.79	6	-5~+80°C	0~0.1	0~0.1	—	—	0~10 ⁻³ Torr	41	63	21	23	19.3	M4×0.7	0.3	
	MUD-8H	Rc1/4"	0.18	1.2	-5~+130°C	0~2	0~2	—	—	0~10 ⁻³ Torr	41	63	21	23	19.3	M4×0.7	0.3	
	MUS-8	Rc1/4"	0.23	2.5	-5~+185°C	—	—	0~0.7	—	—	—	41	63	21	23	19.3	M4×0.7	0.3
	MUD-10	●	Rc3/8"	0.58	4	-5~+80°C	0~1	0~1	—	—	0~10 ⁻³ Torr	53	75	48	20	21	M5×0.8	0.6
	MUD-10		Rc3/8"	0.79	8	-5~+80°C	0~0.3	0~0.5	—	—	0~10 ⁻³ Torr	53	90	48	20	21	M5×0.8	0.8
	MUD-10H		Rc3/8"	0.45	2	-5~+130°C	0~2	0~2	—	—	0~10 ⁻³ Torr	53	75	48	20	21	M5×0.8	0.6
	MUS-10	●	Rc3/8"	0.58	4	-5~+185°C	—	—	0~1	—	—	53	75	48	20	21	M5×0.8	0.6
NO	MUD-6-NO	Rc1/8"	0.23	2.5	-5~+80°C	0~0.7	0~0.7	—	0~0.7	0~10 ⁻³ Torr	41	81	21	23	19.3	M4×0.7	0.4	
	MUD-8-NO	Rc1/4"	0.23	2.5	-5~+80°C	0~0.7	0~0.7	—	0~0.7	0~10 ⁻³ Torr	41	81	21	23	19.3	M4×0.7	0.4	
	MUD-8-NO	Rc1/4"	0.58	4	-5~+80°C	0~0.3	0~0.3	—	0~0.7	0~10 ⁻³ Torr	41	81	21	23	19.3	M4×0.7	0.4	
	MUD-8-NO	Rc1/4"	0.79	6	-5~+80°C	0~0.1	0~0.1	—	0~0.7	0~10 ⁻³ Torr	41	81	21	23	19.3	M4×0.7	0.4	
	MUD-8H-NO	Rc1/4"	0.18	1.2	-5~+130°C	0~2	0~2	—	0~2	0~10 ⁻³ Torr	41	81	21	23	19.3	M4×0.7	0.4	
	MUD-10-NO		Rc3/8"	0.58	4	-5~+80°C	0~1	0~1	—	0~0.7	0~10 ⁻³ Torr	54	106	48	20	21	M5×0.8	0.7

※ The pressure ratings indicated above are based on AC110V/220V. The maximum pressure may vary in case on DC/AC24V.