

MVSI-510 series

ISO-3 SOLENOID VALVE



Mindman

Specification

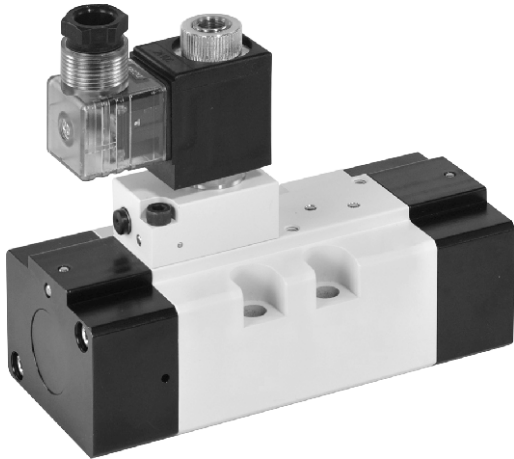

Model	4E1	4E2
No. of port	5	
No. of position	2	
Medium	Air	
Operating pressure range	0.2~0.7 MPa	
Proof pressure	1 MPa	
Effective orifice	65 mm ²	
Response time	60 ms	
Ambient temperature	-5~+50°C (No freezing)	
Voltage	AC110V, 220V (50/60)Hz, DC24V	
Power consumption	AC=13/11VA, DC=10W	
Available voltage range	±10%	
Insulation class	H class	
Weight	1493 g	1778 g

Order example of valve

MVSI - 510 - 4E2 - AC110 - L

MODEL

BODY WIDTH

VOLTAGE

AC220V(50/60)Hz
AC110V(50/60)Hz
DC24V

Blank: DIN connector

L: DIN connector with LED indicator

4: 4 way(5 port)

E1: Single Solenoid
E2: Double Solenoid

Flow features

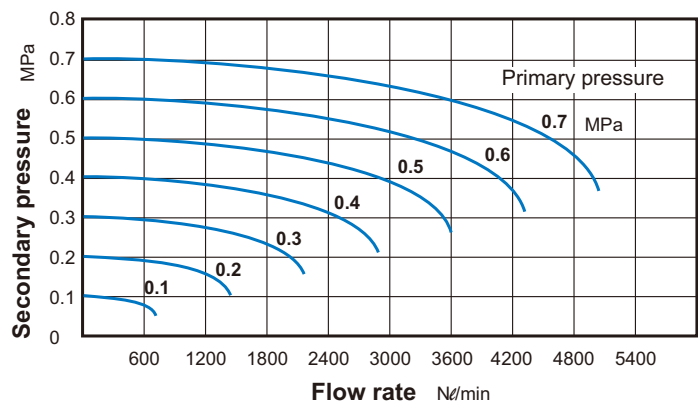

MVSI-510 Dimensions

ISO-3 SOLENOID VALVE



Mindman

MVSI-510-4E1

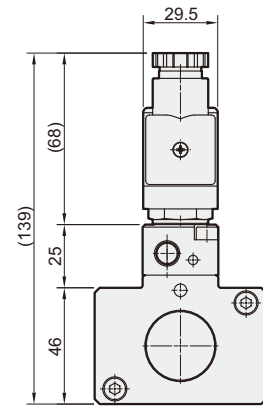
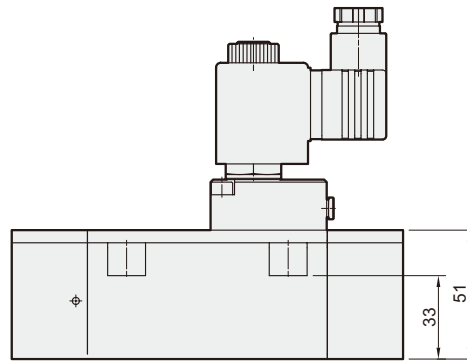
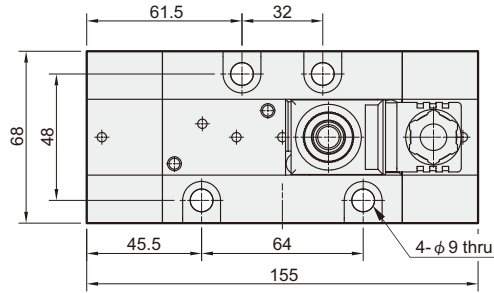
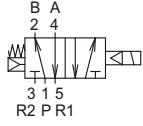

MVSI-510-4E2

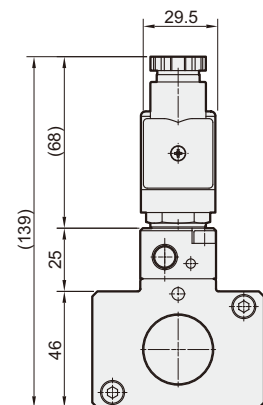
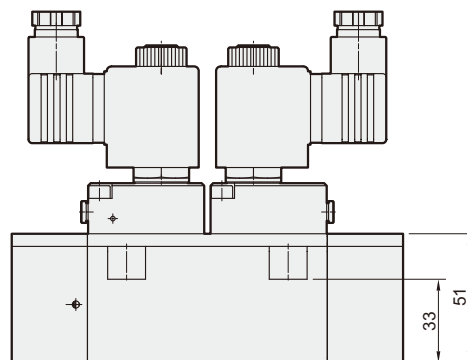
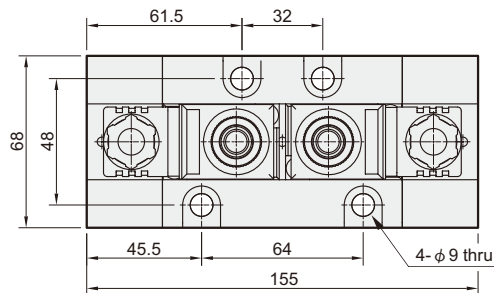
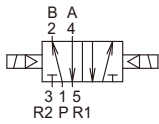

Accessories

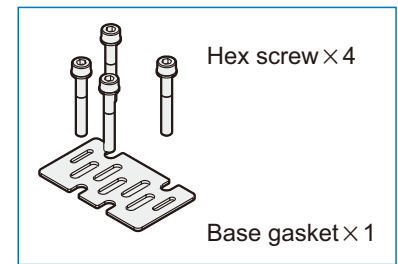

Hex screw × 4

Base gasket × 1