

MVSE-500 series

SOLENOID VALVE

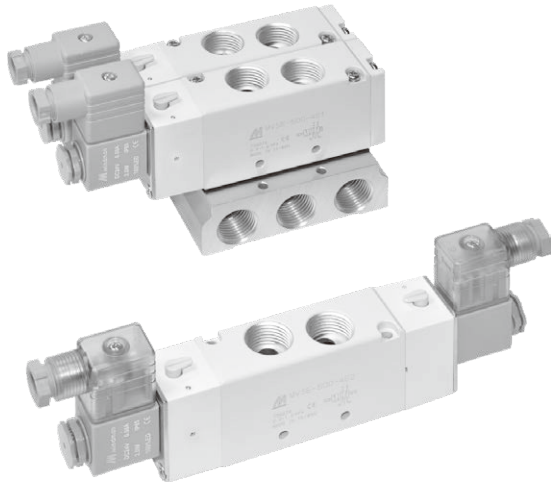

Mindman



Specification

Model	4E1	4E2
Bore No.	15A	
Port size	Rc1/2	
No. of port	5	
No. of position	2	
Medium	Air	
Operating pressure range	0.2~1.2 MPa	
Proof pressure	1.5 MPa	
Effective orifice	41 mm ²	
Response time	50 ms	
Ambient temperature	-5~+50°C (No freezing)	
Voltage	AC110V, 220V (50/60)Hz, DC24V	
Power consumption	AC=6/4.9VA, DC=2W	
Available voltage range	±10%	
Insulation class	F class	
Weight	453 g	554 g

Order example of valve

MVSE — 500 — 4E2 — AC110 — L — G

MODEL

BODY WIDTH

VOLTAGE

AC220V(50/60)Hz
AC110V(50/60)Hz
DC24V

Blank: Din connector

L: Din connector with LED indicator

E: Explosion protection (Table 1)

(E type use black coil)

PORT THREAD

Blank: Rc thread

G: G thread

NPT: NPT thread

4: 4 way (5 port)

E1: Single Solenoid
E2: Double Solenoid

Table 1

Property for explosion-proof type

Anti-explosion class	EEx m II T4
Voltage	AC110V, 220V, (50/60)Hz, DC24V.
Power consumption	AC=4.4VA DC=5W
Available voltage range	±10%
Insulation class	F class

Order example of manifold

MVSE — 500 — 5B3 — G

MODEL

MANIFOLD

5B: 5 port (for body ported type)

MANIFOLD NUMBER

1, 2, 3...

PORT THREAD

Blank: Rc thread

G: G thread

NPT: NPT thread

Flow features

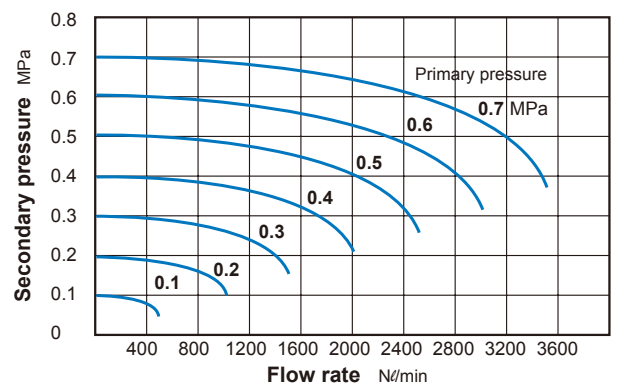

MVSE-500 Dimensions / Manifold

SOLENOID VALVE



MVSE-500-4E1

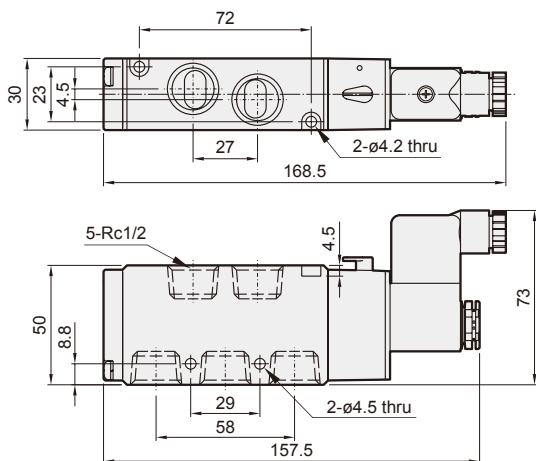
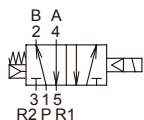

MVSE-500-4E2

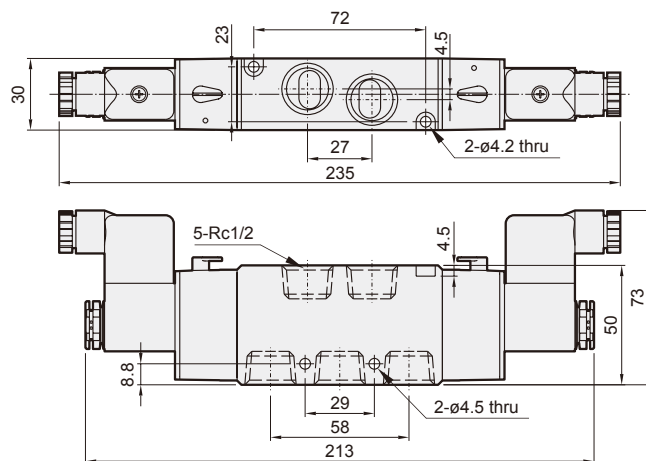
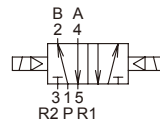

Manifold of solenoid valve

MVSE-500-5B*

5 port (for body ported type)

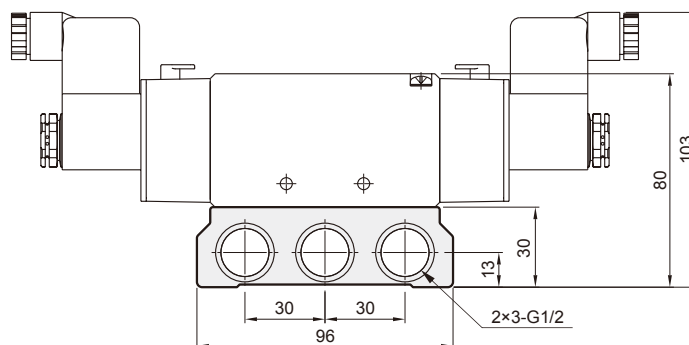
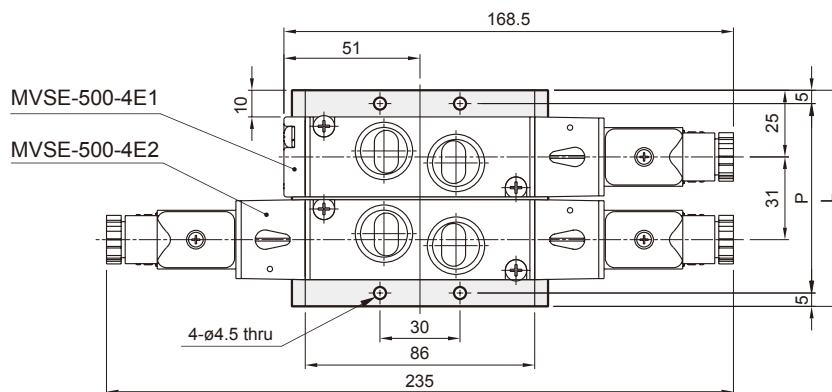

No. of stations	P	L
2	71	81
3	102	112
4	133	143
5	164	174
6	195	205
7	226	236
8	257	267
9	288	298
10	319	329