

MZL112 series

MULTISTAGE VACUUM PUMP

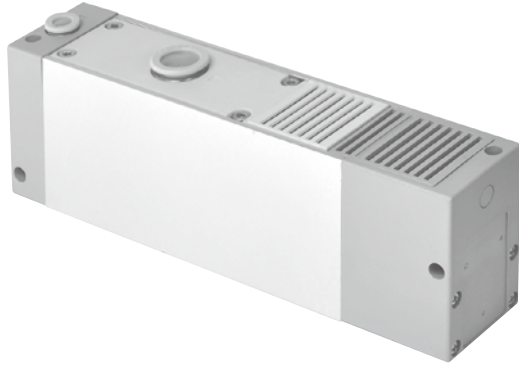

Mindman



Specification

Model	MZL112
Nozzle dia.	1.2 mm
Max. suction flow	100 ℓ/min
Air consumption	63 ℓ/min
Max. vacuum pressure	-84 kPa
Max. operating pressure	0.7 MPa
Supply pressure range	0.2~0.5 MPa
Standard supply pressure	0.4 MPa
Operating temperature range	+5~+50°C
Weight	450 g

Order example

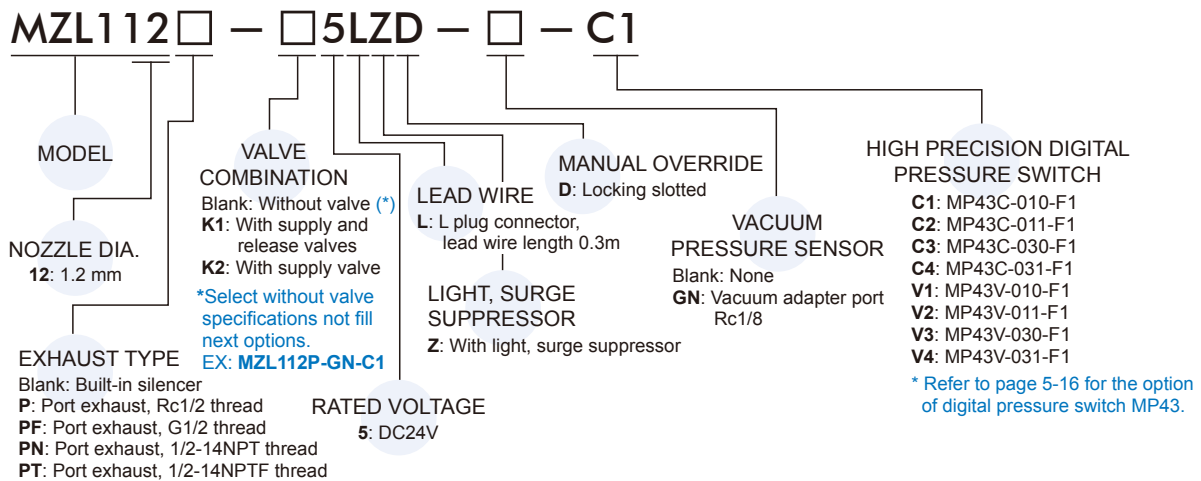

3 stage diffuser construction

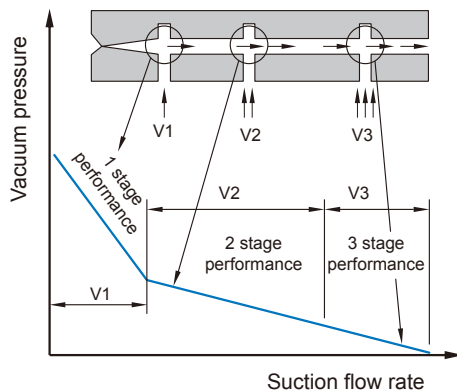

Supply / Release valve specifications

Type of valve actuation	Internal pilot type N.C.
Operating pressure range	0.2~0.5 MPa
Ambient and fluid temperature	-5~+50°C (No freezing)
Response time (for 0.5 MPa)	25ms or less
Max. operating frequency	5Hz
Manual operation	Non-locking push type, slotted locking type
Pilot exhaust type	Pilot valve individual exhaust type, Main valve / Pilot valve common exhaust.
Lubrication	Not required
Mounting position	Unrestricted
Impact / Vibration resistance	150 / 30 m/s ²
Enclosure	Dust proof

MZL112 Dimensions

MULTISTAGE VACUUM PUMP



MZL112

Standard

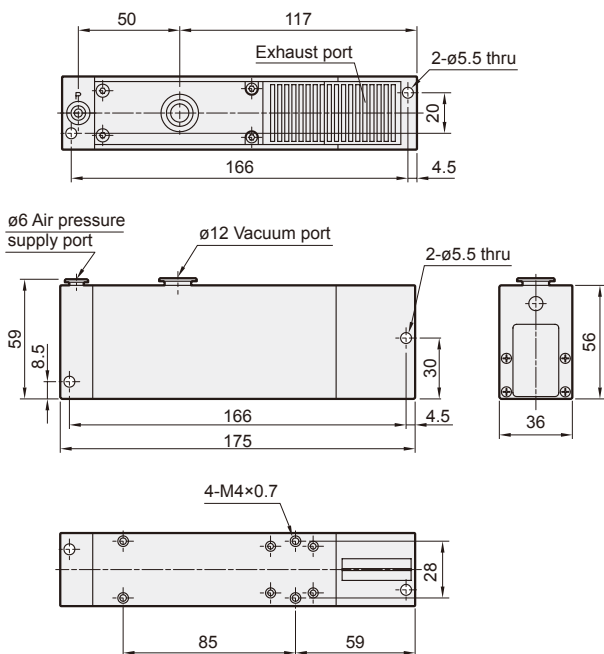

MZL112P

Port exhaust

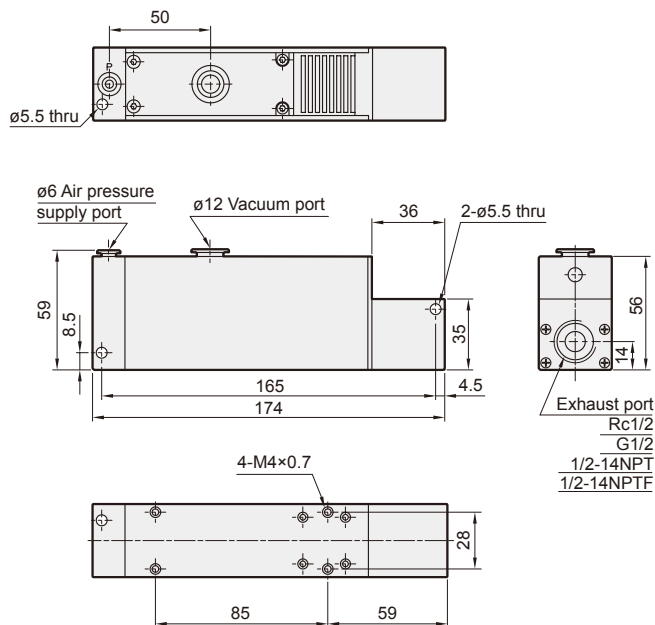

MZL112-GN

With vacuum adapter

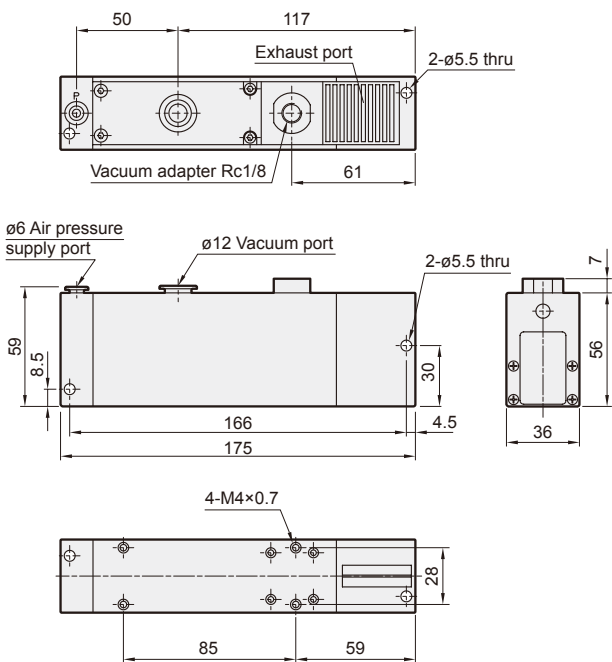

MZL112-GN-C*

With high precision digital pressure switch

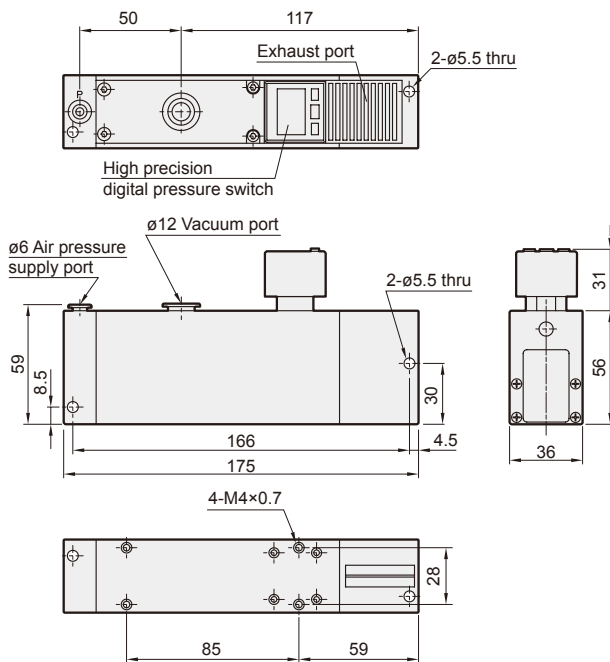

MZL112 Dimensions

MULTISTAGE VACUUM PUMP



MZL112-K1-GN-C*

With supply and release valves

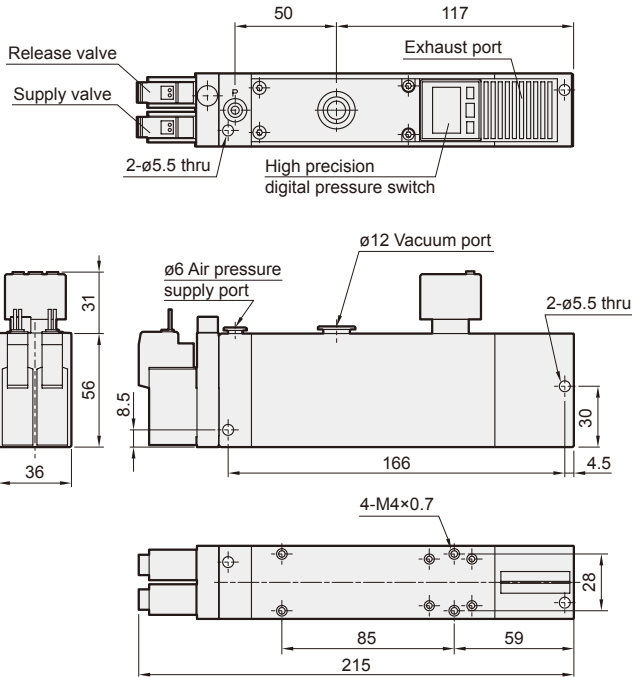

MZL112-K2-GN-C*

With supply valve

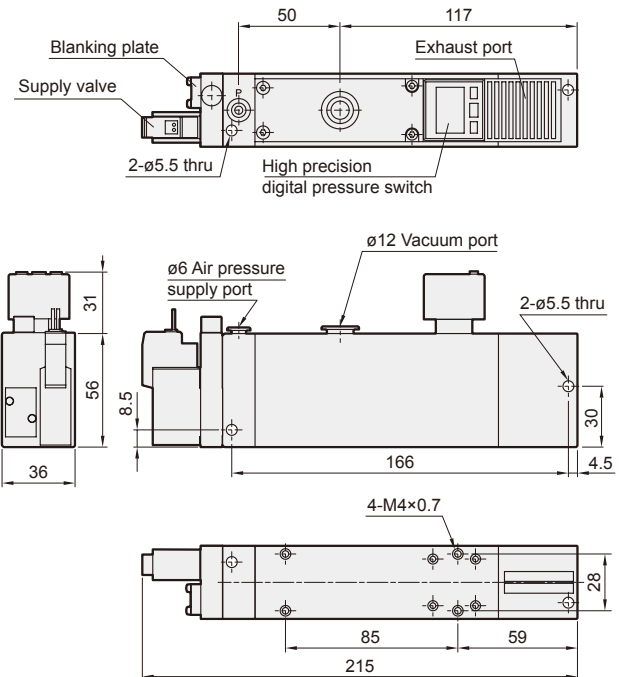

Vacuum flow(ℓ /min) at different vacuum levels (-kPa)

Supply pressure	Air consumption	Vacuum flow(ℓ /min) at different vacuum levels (-kPa)										Max. vacuum level
		0	10	20	30	40	50	60	70	80		
0.4 MPa	63 ℓ /min	0	10	20	30	40	50	60	70	80	-84 kPa	
		100	65	26	20	18.5	13	8	5	2.8		

Evacuation time(s/ ℓ) to reach different vacuum levels (-kPa)

Supply pressure	Air consumption	Evacuation time(s/ ℓ) to reach different vacuum levels (-kPa)										Max. vacuum level
		10	20	30	40	50	60	70	80			
0.4 MPa	63 ℓ /min	10	20	30	40	50	60	70	80	-84 kPa		
		0.05	0.172	0.4	0.67	1.07	1.63	2.46	3.9			

Vacuum characteristics

