

# MVAA-260 series

## PILOT VALVE

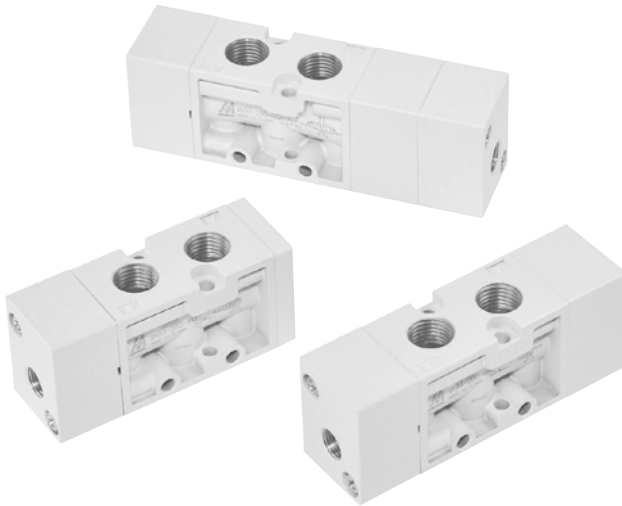

### Specification

Model	4A1	4A2	4A2C.P.R
Bore No.	8A		
Port size	Rc1/4		
No. of port	5		
Medium	Air		
Operating pressure range	0~0.8 MPa		
Proof pressure	1 MPa		
Effective orifice	18 mm <sup>2</sup>		
Pilot pressure range	(0.3×P*+0.1)~0.8 MPa		
Ambient temperature	-5~+60°C (No freezing)		
Weight	153 g	163 g	219 g

\* P: Operating pressure.

### Order example

MVAA – 260 – 4A2C – G

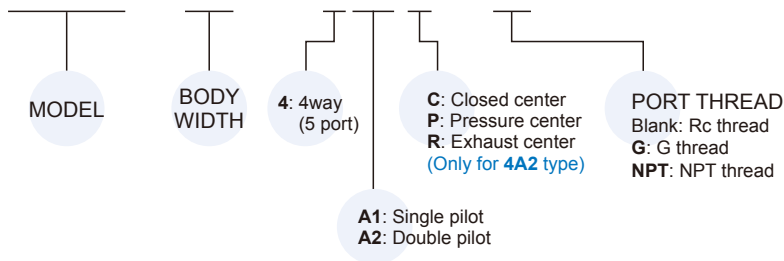

### Flow features

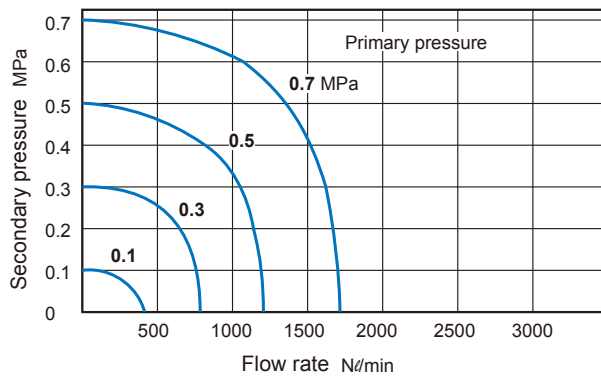

# MVAA-260 Dimensions

PILOT VALVE



## MVAA-260-4A1

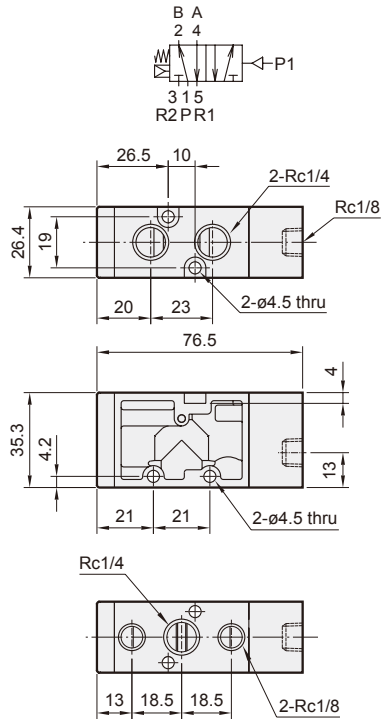

## MVAA-260-4A2

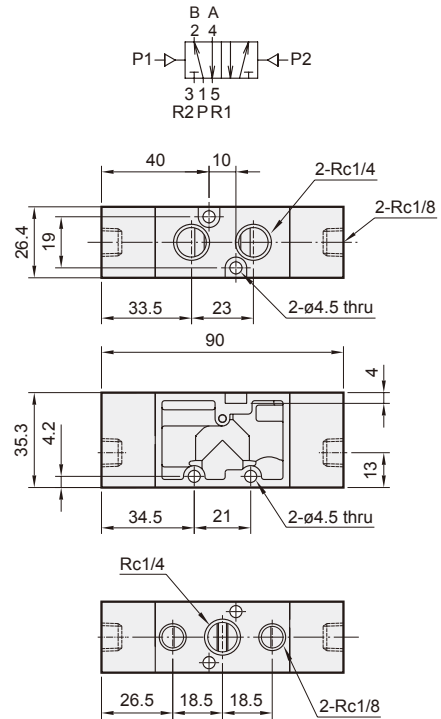

## MVAA-260-4A2C.PR

### MVAA-260-4A2C

### MVAA-260-4A2P

### MVAA-260-4A2R

