

# METSC-10 series

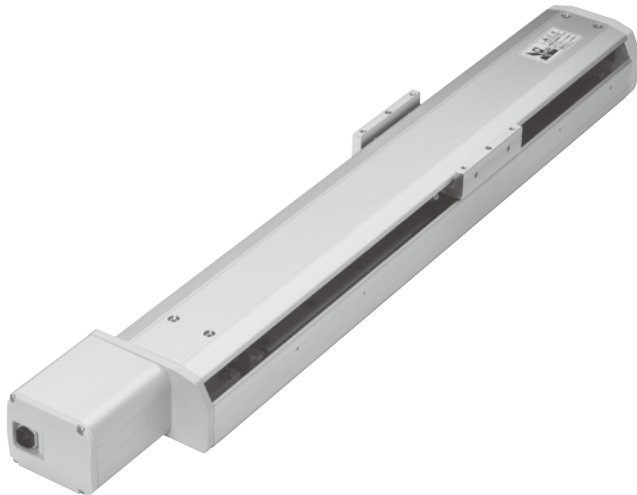

## SLIDER ELECTRIC CYLINDER - BALL SCREW DRIVE (WITH MOTOR)

Mindman



### Specification

Model	METSC-10			
Repeatability (mm)	±0.01			
Ball screw lead (mm)	5	10	20	
Maximum speed (mm/s) (*1)	≤250	≤500	≤1000	
Maximum payload	Horizontal (kg)	≤50	≤30	≤15
	Vertical (kg)	≤12	≤8	≤4
Rated thrust (N)	565	283	141	
Stroke / pitch (mm) (*2)	50~1050 / 50 Pitch			
Motor dimension (mm)	□42			
Ball screw spec (mm)	C7ø16			

\*1. The maximum speed shown here is when software speed setting is 100%. When the stroke is over 750mm, the run-out of the ball screw will occur.

\*2. We recommend to low down the working speed under this circumstances.

### Order example of cylinder

**METSC-10 — L05 — 100 — M — TC100 — 03 — A0001**

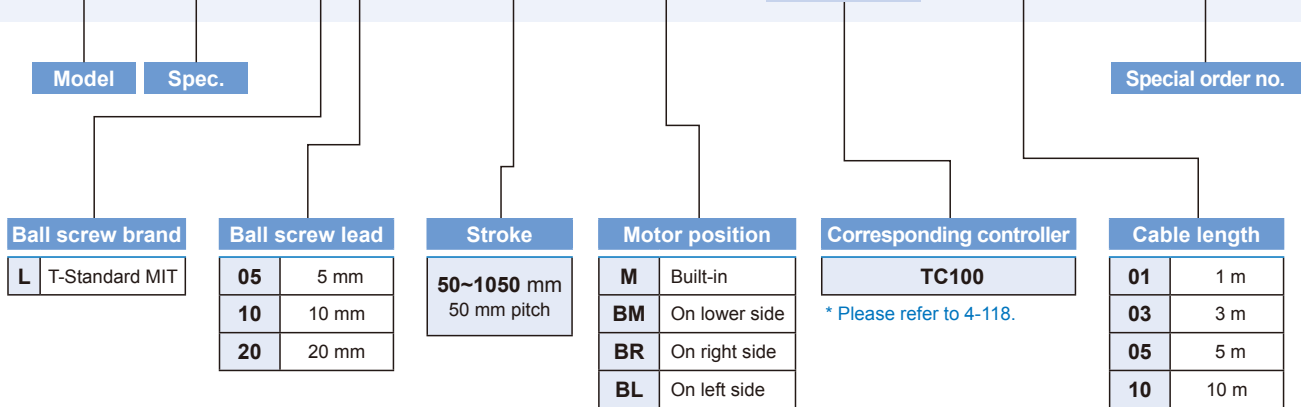

### Order example of controller

**TC100 — 03**

Controller	Cable length
TC100	Blank No cable
	01 1 m
	03 3 m
	05 5 m
	10 10 m

\* Standard: 3 m

### Speed-payload curve diagram

Horizontal

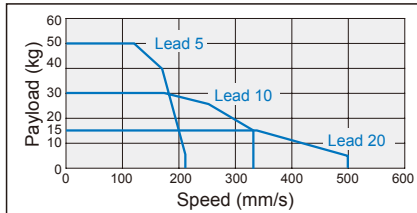

Vertical

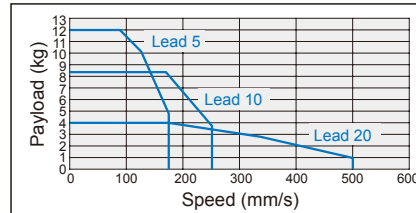

### Allowable overhang

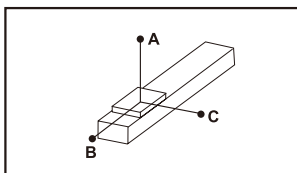

Unit: mm

Horizontal installation	Payload (kg)	Unit: mm		
		A	B	C
Lead 5	10kg	900	55	55
	30kg	680	40	40
	50kg	420	23	23
Lead 10	10kg	650	75	75
	20kg	450	60	60
	30kg	350	40	40
Lead 20	5kg	550	130	120
	10kg	400	90	90
	15kg	300	70	65

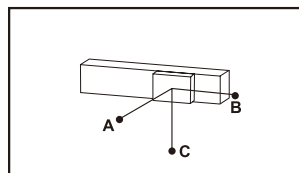

Unit: mm

Wall installation	Payload (kg)	Unit: mm		
		A	B	C
Lead 5	10kg	65	65	1000
	30kg	55	55	900
	50kg	45	45	750
Lead 10	10kg	80	80	700
	20kg	60	60	500
	30kg	40	40	350
Lead 20	5kg	60	60	280
	10kg	40	45	185
	15kg	30	30	140

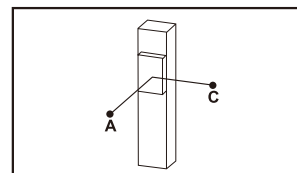

Unit: mm

Vertical installation	Payload (kg)	Unit: mm	
		A	C
Lead 5	8kg	200	200
	10kg	160	160
	12kg	130	130
Lead 10	4kg	300	300
	6kg	200	200
	8kg	160	160
Lead 20	2kg	520	520
	3kg	350	350
	4kg	250	250

### Static loading moment

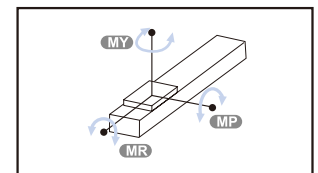

Unit: N.m

MY	110
MP	110
MR	120

# METSC-10 Dimensions



## SLIDER ELECTRIC CYLINDER - BALL SCREW DRIVE (WITH MOTOR)

mindman

**M**

Motor built-in

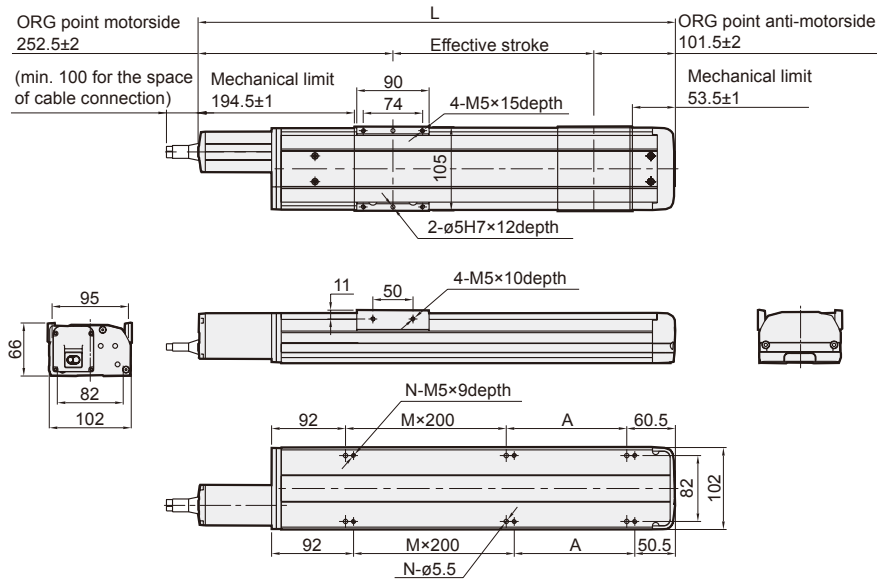

Unit: mm

Stroke	50	100	150	200	250	300	350	400	450	500	550	600	650	700	750	800	850	900	950	1000	1050
<b>L</b>	394	444	494	544	594	644	694	744	794	844	892	944	994	1044	1094	1144	1194	1244	1294	1344	1394
<b>A</b>	150	200	50	100	150	200	50	100	150	200	50	100	150	200	50	100	150	200	50	100	150
<b>M</b>	0	0	1	1	1	1	2	2	2	2	3	3	3	3	4	4	4	4	5	5	5
<b>N</b>	4	4	6	6	6	6	8	8	8	8	10	10	10	10	12	12	12	12	14	14	14
<b>KG</b>	5.06	5.44	5.82	6.21	6.59	6.98	7.36	7.75	8.13	8.52	8.9	9.29	9.67	10.06	10.44	10.83	11.21	11.6	11.98	12.37	12.75

**BM**

Motor on lower side

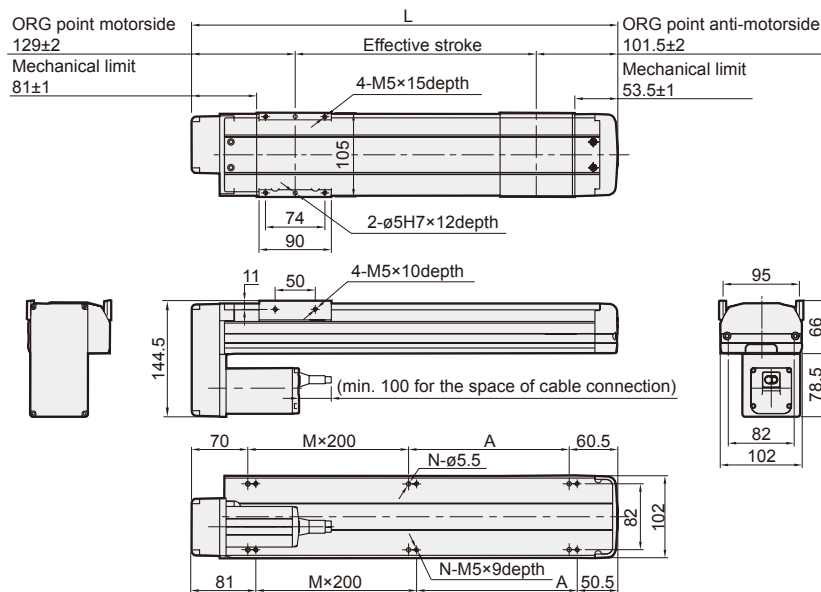

Unit: mm

Stroke	50	100	150	200	250	300	350	400	450	500	550	600	650	700	750	800	850	900	950	1000	1050
<b>L</b>	280.5	330.5	380.5	430.5	480.5	530.5	580.5	630.5	680.5	730.5	780.5	830.5	880.5	930.5	980.5	1030.5	1080.5	1130.5	1180.5	1230.5	1280.5
<b>A</b>	150	200	50	100	150	200	50	100	150	200	50	100	150	200	50	100	150	200	50	100	150
<b>M</b>	0	0	1	1	1	1	2	2	2	2	3	3	3	3	4	4	4	4	5	5	5
<b>N</b>	4	4	6	6	6	6	8	8	8	8	10	10	10	10	12	12	12	12	14	14	14
<b>KG</b>	5.27	5.66	6.05	6.43	6.82	7.2	7.59	7.97	8.36	8.74	9.13	9.51	9.9	10.28	10.67	11.05	11.44	11.82	12.21	12.59	12.98

# METSC-10 Dimensions



## SLIDER ELECTRIC CYLINDER - BALL SCREW DRIVE (WITH MOTOR)

mindman

**BL**

Motor on left side

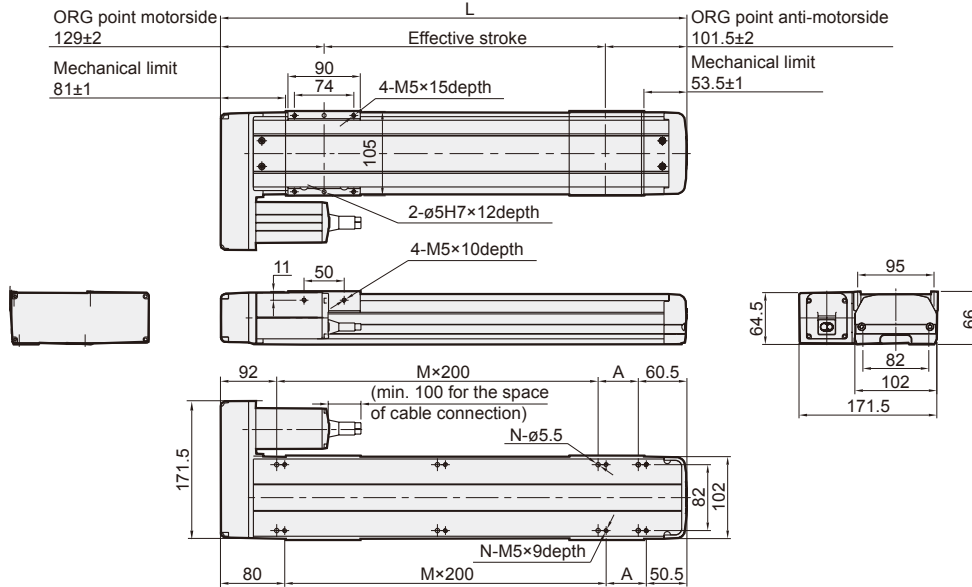

Unit: mm

Stroke	50	100	150	200	250	300	350	400	450	500	550	600	650	700	750	800	850	900	950	1000	1050
<b>L</b>	394	444	494	544	594	644	694	744	794	844	892	944	994	1044	1094	1144	1194	1244	1294	1344	1394
<b>A</b>	150	200	50	100	150	200	50	100	150	200	50	100	150	200	50	100	150	200	50	100	150
<b>M</b>	0	0	1	1	1	1	2	2	2	2	3	3	3	3	4	4	4	4	5	5	5
<b>N</b>	4	4	6	6	6	6	8	8	8	8	10	10	10	10	12	12	12	12	14	14	14
<b>KG</b>	5.06	5.44	5.82	6.21	6.59	6.98	7.36	7.75	8.13	8.52	8.9	9.29	9.67	10.06	10.44	10.83	11.21	11.6	11.98	12.37	12.75

**BR**

Motor on right side

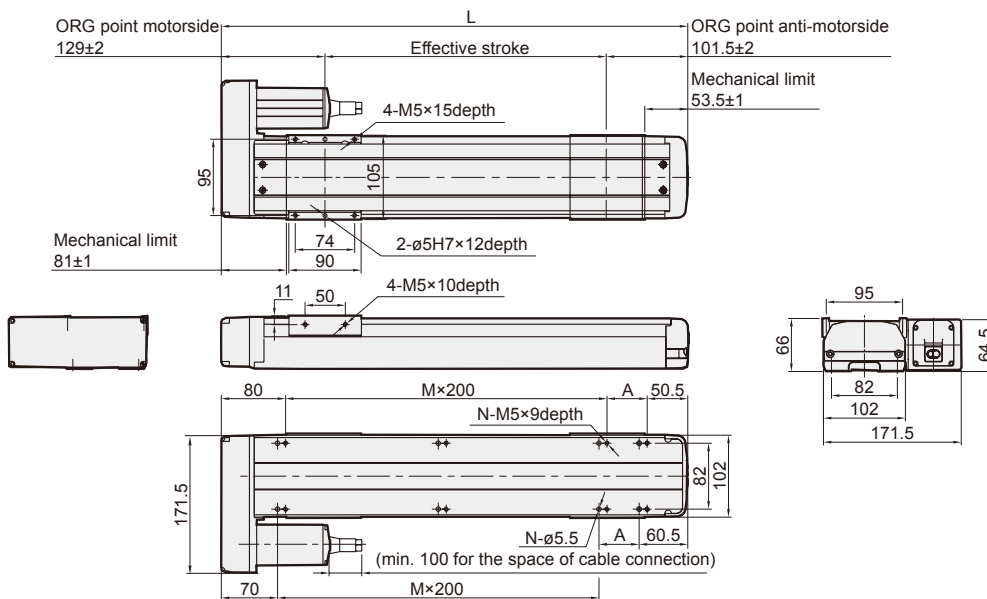

Unit: mm

Stroke	50	100	150	200	250	300	350	400	450	500	550	600	650	700	750	800	850	900	950	1000	1050
<b>L</b>	280.5	330.5	380.5	430.5	480.5	530.5	580.5	630.5	680.5	730.5	780.5	830.5	880.5	930.5	980.5	1030.5	1080.5	1130.5	1180.5	1230.5	1280.5
<b>A</b>	150	200	50	100	150	200	50	100	150	200	50	100	150	200	50	100	150	200	50	100	150
<b>M</b>	0	0	1	1	1	1	2	2	2	2	3	3	3	3	4	4	4	4	5	5	5
<b>N</b>	4	4	6	6	6	6	8	8	8	8	10	10	10	10	12	12	12	12	14	14	14
<b>KG</b>	5.27	5.66	6.05	6.43	6.82	7.2	7.59	7.97	8.36	8.74	9.13	9.51	9.9	10.28	10.67	11.05	11.44	11.82	12.21	12.59	12.98