

METS-22 series



SLIDER ELECTRIC CYLINDER - BALL SCREW DRIVE (WITHOUT MOTOR)

Mindman



Specification

Model	METS-22				
Repeatability (mm)	±0.01				
Belt lead (mm)	5	10	25	40	
Max. speed	250	500	1250	2000	
Servo motor	750W				
Max. payload (kg)	Horizontal	150	150	120	60
	Vertical	55	45	20	10
Rated thrust (N)	2563	1281	640	320	
Stroke (mm)	100~1500 / 50 pitch				
Ball screw ø (mm)	C7ø25	C7ø25	C7ø25	C7ø20	
High rigidity linear guide (mm)	W23×H18				
Coupling (mm)	17×19			12×19	
Home sensor	Outside	EE-SX672 (NPN)			
	Built in	EE-SX674 (NPN)			

Sensor layout

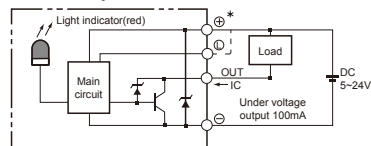

Order example

METS-22 - L10 - 100 - M - M75B - C4 - 0001

Model

Spec.

Stroke

100~1500 mm

50 mm pitch

Special order no.

Ball screw brand

L	T-Standard MIT
---	----------------

Ball screw lead

Spec.	Lead
05	5 mm
10	10 mm
25	25 mm
40	40 mm

Motor position

M	Built-in
BC	Exposed
BM	On lower side
BR	On right side
BL	On left side

Motor brand, power output, brakes

Brand	Power	Brake
M	Mitsubishi	75 750W B
P	Panasonic	
Y	Yaskawa	
T	Delta	

* Need not show B with no brake.

Home sensor

In side	
A	Motor side
B	Opposite motor side
Out side	
C	Motor side
D	Opposite motor side
No sensor	
E	None

Limit sensor

In side	
1	1 Pc
2	2 Pcs
Out side	
3	1 Pc
4	2 Pcs
No sensor	
5	None

Allowable overhang

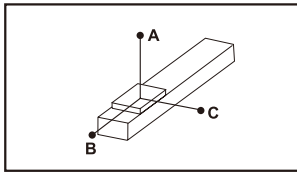

Unit: mm

Horizontal installation		A	B	C
Lead 5	60kg	3672	653	866
	100kg	3000	370	497
	150kg	2493	273	363
Lead 10	60kg	2652	899	994
	100kg	1775	526	593
	150kg	1396	317	267
Lead 25	50kg	2862	956	1191
	80kg	2412	581	773
	120kg	2025	373	556
Lead 40	10kg	4010	4010	3460
	30kg	3011	2003	1911
	60kg	2453	730	980

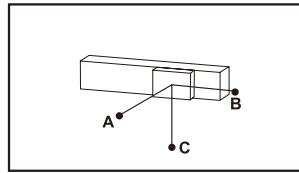

Unit: mm

Wall installation		A	B	C
Lead 5	60kg	795	525	3657
	100kg	416	248	2993
	150kg	290	159	2479
Lead 10	60kg	982	815	2573
	100kg	569	442	1680
	150kg	337	232	1258
Lead 25	50kg	1207	879	2862
	80kg	779	504	2412
	120kg	515	295	2025
Lead 40	10kg	3057	4113	4113
	30kg	2112	2108	3387
	60kg	1020	668	2461

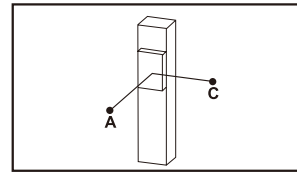

Unit: mm

Vertical installation		A	C
Lead 5	30kg	2688	2688
	50kg	1893	1893
	70kg	1640	1640
Lead 10	20kg	2297	2297
	30kg	1518	1518
	45kg	999	999
Lead 25	15kg	2767	2767
	20kg	2100	2100
	25kg	1702	1702
Lead 40	-	-	-
	-	-	-
	-	-	-

Static loading moment

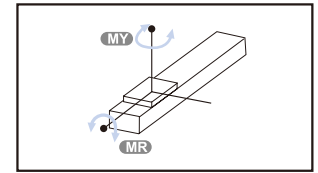

Unit: N.m

MY	2052
MP	2052
MR	1810

Standard servo motors

Brand	Mark	Brake	Watt	AC-Voltage	Motor model	Compatible driver model
Mitsubishi	M	No brake(Horizontal type)	750	220	HF-KP73	MR-J3-70A
		With brake(Vertical type)	750	220	HF-KP73B	MR-J3-70A
Panasonic	P	No brake(Horizontal type)	750	220	MHMD082P1S	MADDT3520
		With brake(Vertical type)	750	220	MHMD082P1T	MADDT3520
Delta	T	No brake(Horizontal type)	750	220	ECMA-C20807ES	ASD-B20721-B
		With brake(Vertical type)	750	220	ECMA-C20807FS	ASD-B20721-B

METS-22 Dimensions – Servo motor 750W



SLIDER ELECTRIC CYLINDER - BALL SCREW DRIVE (WITHOUT MOTOR)

mindman

BC

Motor exposed

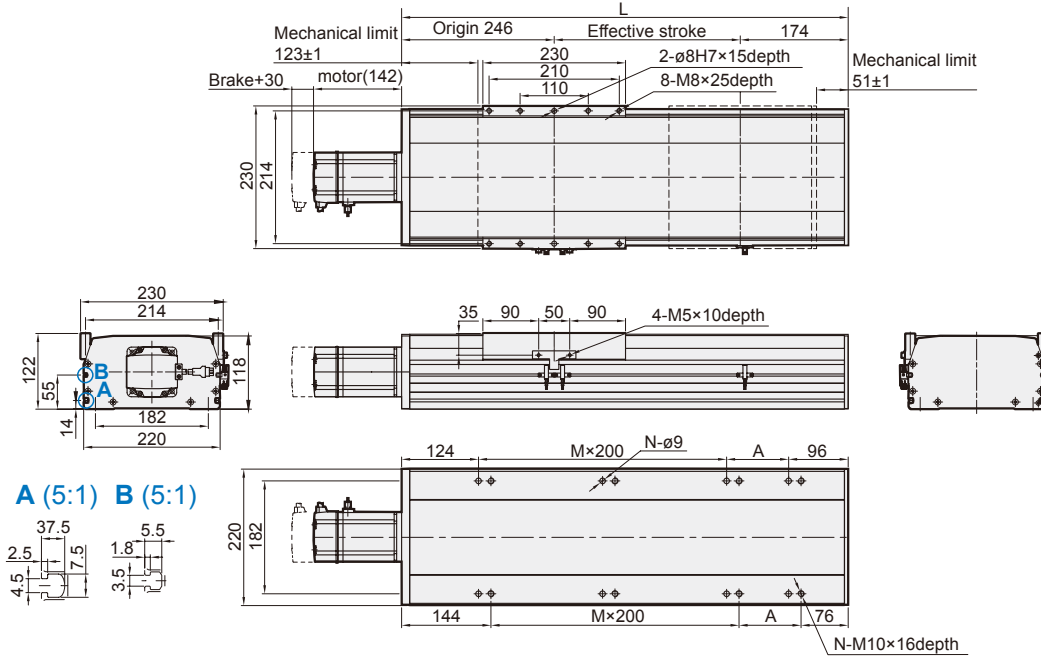

Unit: mm

Stroke	100	150	200	250	300	350	400	450	500	550	600	650	700	750	800	850	900	950	1000	1050	1100	1150	1200	1250	1300	1350	1400	1450	1500
L	520	570	620	670	720	770	820	870	920	970	1020	1070	1120	1170	1220	1270	1320	1370	1420	1470	1520	1570	1620	1670	1720	1770	1820	1870	1920
A	100	150	200	50	100	150	200	50	100	150	200	50	100	150	200	50	100	150	200	50	100	150	200	50	100	150	200	50	100
M	1	1	1	2	2	2	2	3	3	3	3	3	4	4	4	4	5	5	5	6	6	6	6	7	7	7	7	8	8
N	6	6	6	8	8	8	8	10	10	10	10	12	12	12	12	14	14	14	14	16	16	16	16	18	18	18	18	20	20
KG	26.86	28.32	29.78	31.24	32.7	34.16	35.62	37.08	38.54	40	41.46	42.92	44.38	45.84	47.3	48.76	50.22	51.68	53.14	54.6	56.06	57.52	58.98	60.44	61.9	63.36	64.82	66.28	67.74

M

Motor built-in

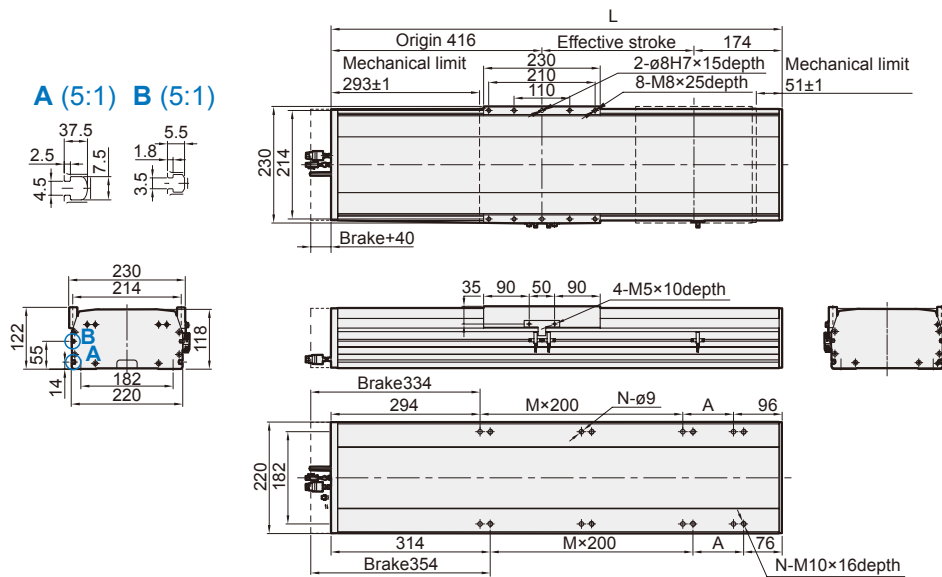

Unit: mm

Stroke	100	150	200	250	300	350	400	450	500	550	600	650	700	750	800	850	900	950	1000	1050	1100	1150	1200	1250	1300	1350	1400	1450	1500
L	690	740	790	840	890	940	990	1040	1090	1140	1190	1240	1290	1340	1390	1440	1490	1540	1590	1640	1690	1740	1790	1840	1890	1940	1990	2040	2090
A	100	150	200	50	100	150	200	50	100	150	200	50	100	150	200	50	100	150	200	50	100	150	200	50	100	150	200	50	100
M	1	1	1	2	2	2	2	3	3	3	3	4	4	4	4	5	5	5	5	6	6	6	6	7	7	7	7	8	8
N	6	6	6	8	8	8	8	10	10	10	10	12	12	12	12	14	14	14	14	16	16	16	16	18	18	18	18	20	20
KG	29.32	30.79	32.26	33.73	35.2	36.67	38.14	39.61	41.08	42.55	44.02	45.49	46.96	48.43	49.9	51.37	52.84	54.31	55.78	57.25	58.72	60.19	61.66	63.13	64.6	66.07	67.54	69.01	70.48

METS-22 Dimensions – Servo motor 750W



SLIDER ELECTRIC CYLINDER - BALL SCREW DRIVE (WITHOUT MOTOR)

Mindman

BL

Motor on left side

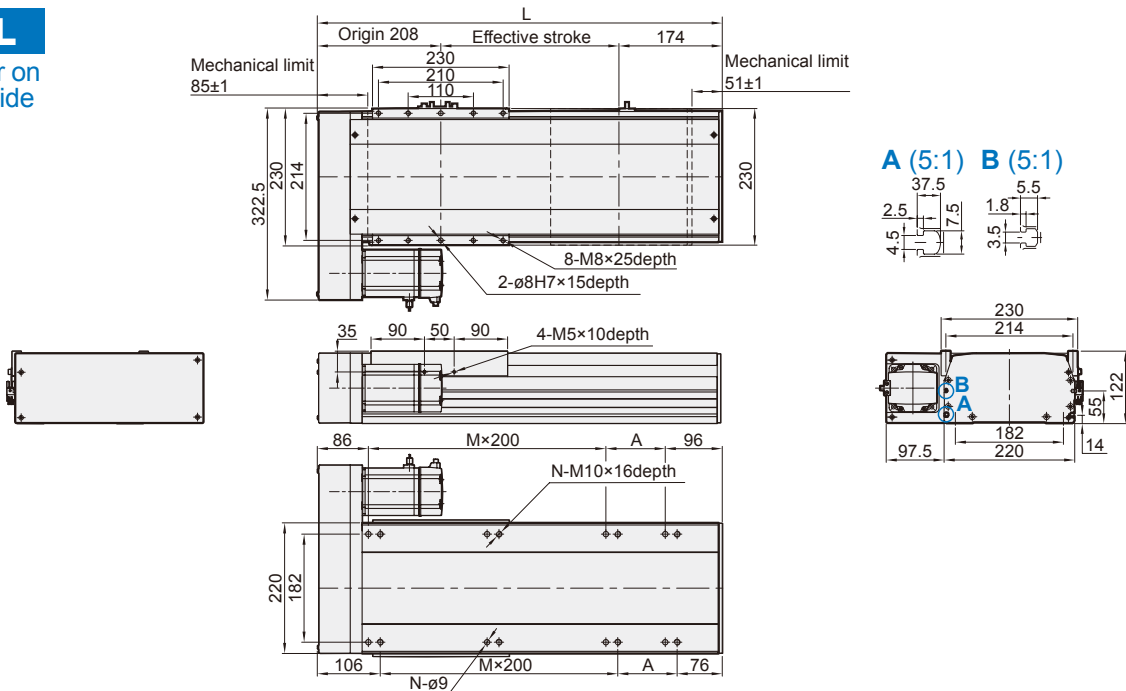

Unit: mm

Stroke	100	150	200	250	300	350	400	450	500	550	600	650	700	750	800	850	900	950	1000	1050	1100	1150	1200	1250	1300	1350	1400	1450	1500
L	482	532	582	632	682	732	782	832	882	932	982	1032	1082	1132	1182	1232	1282	1332	1382	1432	1482	1532	1582	1632	1682	1732	1782	1832	1882
A	100	150	200	50	100	150	200	50	100	150	200	50	100	150	200	50	100	150	200	50	100	150	200	50	100	150	200	50	100
M	1	1	1	2	2	2	2	3	3	3	3	4	4	4	4	5	5	5	5	6	6	6	6	7	7	7	7	8	8
N	6	6	6	8	8	8	8	10	10	10	10	12	12	12	12	14	14	14	14	16	16	16	16	18	18	18	18	20	20
KG	25.66	27.12	28.58	30.04	31.5	32.96	34.42	35.88	37.34	38.8	40.26	41.72	43.18	44.64	46.1	47.56	49.02	50.48	51.94	53.4	54.86	56.32	57.78	59.24	60.7	62.16	63.62	65.08	66.54

BR

Motor on right side

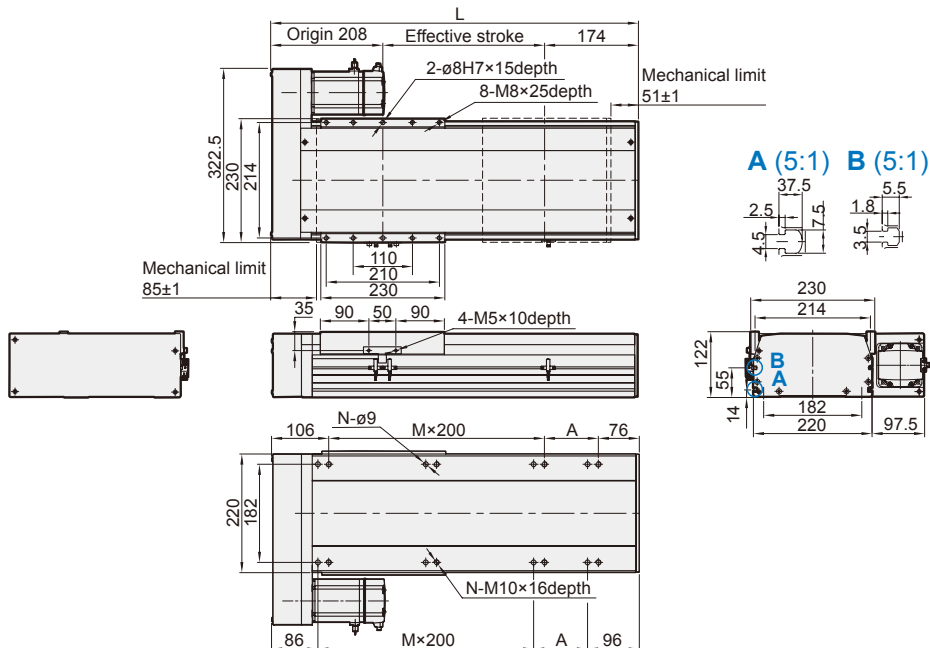

Unit: mm

Stroke	100	150	200	250	300	350	400	450	500	550	600	650	700	750	800	850	900	950	1000	1050	1100	1150	1200	1250	1300	1350	1400	1450	1500
L	482	532	582	632	682	732	782	832	882	932	982	1032	1082	1132	1182	1232	1282	1332	1382	1432	1482	1532	1582	1632	1682	1732	1782	1832	1882
A	100	150	200	50	100	150	200	50	100	150	200	50	100	150	200	50	100	150	200	50	100	150	200	50	100	150	200	50	100
M	1	1	1	2	2	2	2	3	3	3	3	4	4	4	4	5	5	5	5	6	6	6	6	7	7	7	7	8	8
N	6	6	6	8	8	8	8	10	10	10	10	12	12	12	12	14	14	14	14	16	16	16	16	18	18	18	18	20	20
KG	25.66	27.12	28.58	30.04	31.5	32.96	34.42	35.88	37.34	38.8	40.26	41.72	43.18	44.64	46.1	47.56	49.02	50.48	51.94	53.4	54.86	56.32	57.78	59.24	60.7	62.16	63.62	65.08	66.54

METS-22 Dimensions – Servo motor 750W



SLIDER ELECTRIC CYLINDER - BALL SCREW DRIVE (WITHOUT MOTOR)

Mindman

BM

Motor on lower side

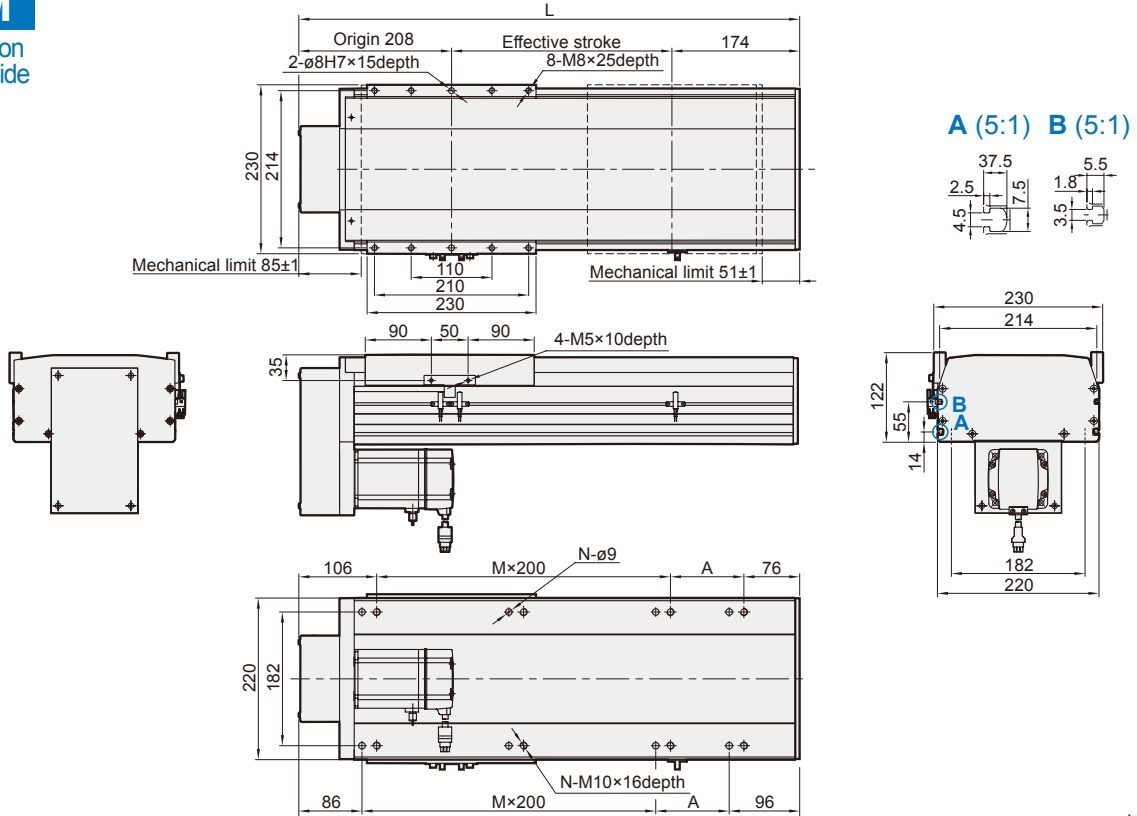

Unit: mm

Stroke	100	150	200	250	300	350	400	450	500	550	600	650	700	750	800	850	900	950	1000	1050	1100	1150	1200	1250	1300	1350	1400	1450	1500
L	482	532	582	632	682	732	782	832	882	932	982	1032	1082	1132	1182	1232	1282	1332	1382	1432	1482	1532	1582	1632	1682	1732	1782	1832	1882
A	100	150	200	50	100	150	200	50	100	150	200	50	100	150	200	50	100	150	200	50	100	150	200	50	100	150	200	50	100
M	1	1	1	2	2	2	2	3	3	3	3	4	4	4	4	5	5	5	5	6	6	6	6	7	7	7	7	8	8
N	6	6	6	8	8	8	8	10	10	10	10	12	12	12	12	14	14	14	14	16	16	16	16	18	18	18	18	20	20
KG	25.66	27.12	28.58	30.04	31.5	32.96	34.42	35.88	37.34	38.8	40.26	41.72	43.18	44.64	46.1	47.56	49.02	50.48	51.94	53.4	54.86	56.32	57.78	59.24	60.7	62.16	63.62	65.08	66.54