

METS-17 series



SLIDER ELECTRIC CYLINDER - BALL SCREW DRIVE (WITHOUT MOTOR)

Mindman



Sensor layout

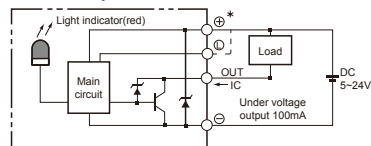

Specification

Model	METS-17				
Repeatability (mm)	±0.01				
Belt lead (mm)	5	10	20	40	
Max. speed (mm/s)	250	500	1000	2000	
Stroke (mm)	100~1250 / 50 pitch				
Ball screw Ø (mm)	C7Ø20				
High rigidity linear guide (mm)	W20×H15				
Home sensor	Outside	EE-SX672 (NPN)			
	Built in	EE-SX674 (NPN)			
Servo motor		400 W			
Max. payload (kg)	Horizontal	120	110	75	35
	Vertical	40	30	14	7
Rated thrust (N)		1388	694	347	174
Coupling (mm)	12×14				
Servo motor		750 W			
Max. payload (kg)	Horizontal	120	120	83	50
	Vertical	50	40	25	10
Rated thrust (N)		2563	1281	640	320
Coupling (mm)	12×19				

Order example

METS-17 - L05 - 100 - M - M40B - C4 - 0001

Model Spec. Stroke Special order no.

100~1250 mm
50 mm pitch

Ball screw brand	Ball screw lead	Motor position	Motor brand, power output, brakes	Home sensor	Limit sensor
L T-Standard MIT	05 5 mm	M ^{*1} Built-in	M Mitsubishi	In side	In side
	10 10 mm	BC Exposed	P Panasonic 40: 400W	A Motor side	1 1 Pc
	20 20 mm	BM On lower side	Y Yaskawa 75: 750W	B Opposite motor side	2 2 Pcs
	40 40 mm	BR On right side	T Delta	Out side	Out side
		BL On left side		C Motor side	3 1 Pc
				D Opposite motor side	4 2 Pcs
				No sensor	No sensor
				E None	5 None

*1. METS-17 / 75W is not applicable motor installation "M".

*2 Need not show B with no brake.

Allowable overhang

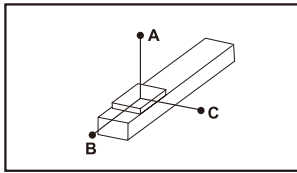

Unit: mm

Horizontal installation		A	B	C
Lead 5	60kg	2980	435	577
	100kg	2000	207	331
	110kg	1846	202	269
Lead 10	60kg	2440	428	570
	75kg	2010	253	336
	90kg	1851	207	274
Lead 20	30kg	2652	899	994
	50kg	1775	526	593
	75kg	1396	317	267
Lead 40	10kg	3545	2738	2003
	20kg	2545	1360	1185
	35kg	2640	664	739

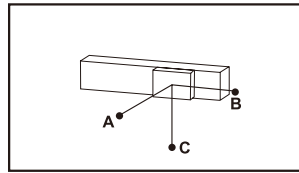

Unit: mm

Wall installation		A	B	C
Lead 5	60kg	530	350	2438
	100kg	277	165	1995
	110kg	215	118	1836
Lead 10	60kg	533	353	2441
	75kg	293	179	2010
	90kg	230	133	1851
Lead 20	30kg	982	815	2573
	50kg	569	442	1680
	75kg	337	232	1258
Lead 40	10kg	2020	2671	3500
	20kg	1200	1281	2480
	35kg	755	591	2518

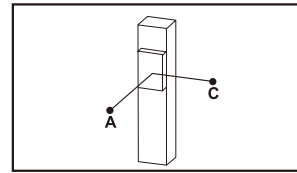

Unit: mm

Vertical installation		A	C
Lead 5	20kg	1510	1220
	30kg	1210	990
	40kg	992	962
Lead 10	15kg	1778	1778
	25kg	1050	1050
	30kg	750	750
Lead 16	5kg	1700	1700
	10kg	2202	2202
	14kg	1485	1485
Lead 20	7kg	650	650
	-	-	-
	-	-	-

Static loading moment

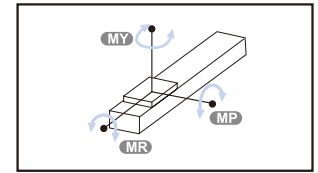

Unit: N.m

MY	1032
MP	1034
MR	908

Standard servo motors

Brand	Mark	Brake	Watt	AC-Voltage	Motor model	Compatible driver model
Mitsubishi	M	No brake(Horizontal type)	400	220	HF-KP43	MR-J3-40A
			750	220	HF-KP73	MR-J3-70A
		With brake(Vertical type)	400	220	HF-KP43B	MR-J3-40A
			750	220	HF-KP73B	MR-J3-70A
Panasonic	P	No brake(Horizontal type)	400	220	MHMD042P1S	MADDT2210
			750	220	MHMD082P1S	MADDT3520
		With brake(Vertical type)	400	220	MHMD042P1T	MADDT2210
			750	220	MHMD082P1T	MADDT3520
Delta	T	No brake(Horizontal type)	400	220	ECMA-C20604ES	ASD-B20421-B
			750	220	ECMA-C20807ES	ASD-B20721-B
		With brake(Vertical type)	400	220	ECMA-C20604FS	ASD-B20421-B
			750	220	ECMA-C20807FS	ASD-B20721-B

METS-17 Dimensions – Servo motor 400W



SLIDER ELECTRIC CYLINDER - BALL SCREW DRIVE (WITHOUT MOTOR)

BC

Motor exposed

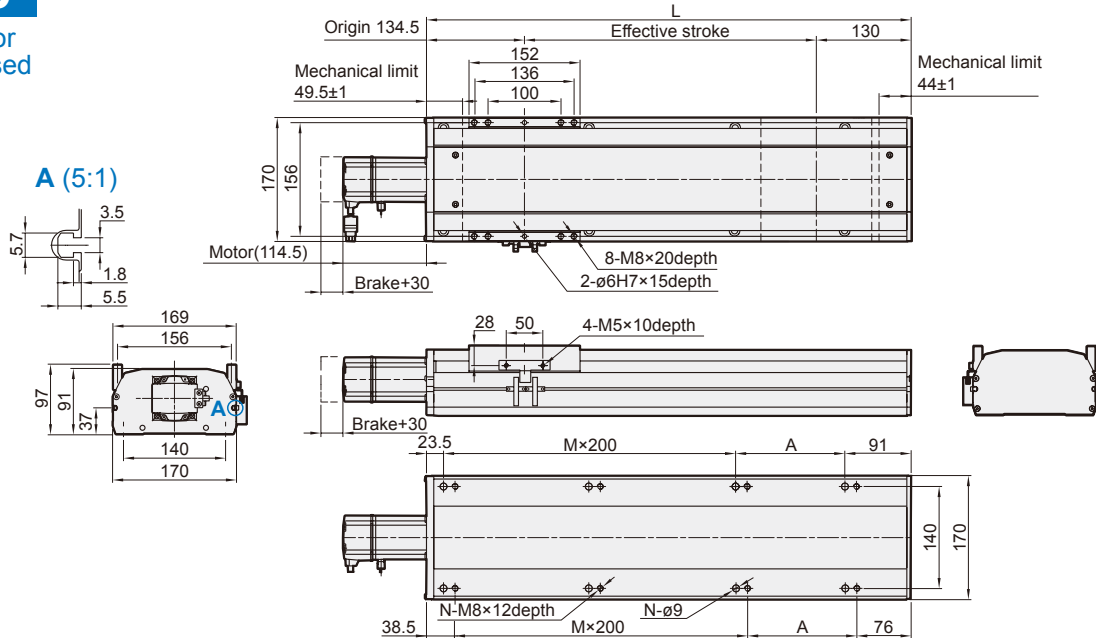

Unit: mm

Stroke	100	150	200	250	300	350	400	450	500	550	600	650	700	750	800	850	900	950	1000	1050	1100	1150	1200	1250
L	364.5	414.5	464.5	514.5	564.5	614.5	664.5	714.5	764.5	814.5	864.5	914.5	964.5	1014.5	1064.5	1114.5	1164.5	1214.5	1264.5	1314.5	1364.5	1414.5	1464.5	1514.5
A	50	100	150	200	50	100	150	200	50	100	150	200	50	100	150	200	50	100	150	200	50	100	150	200
M	1	1	1	1	2	2	2	2	3	3	3	3	4	4	4	4	5	5	5	5	6	6	6	6
N	6	6	6	6	8	8	8	8	10	10	10	10	12	12	12	12	14	14	14	14	16	16	16	16
KG	10.02	10.79	11.57	12.34	13.11	13.88	14.65	15.42	16.19	16.96	17.73	18.5	19.28	20.5	20.82	21.59	22.36	23.13	23.9	24.67	25.44	26.21	26.98	27.75

M

Motor built-in

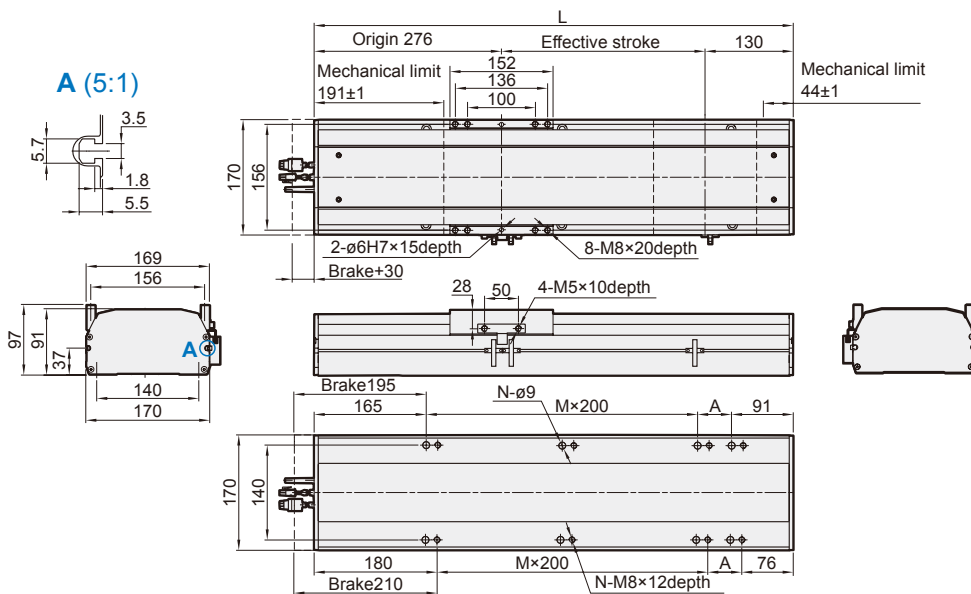

Unit: mm

Stroke	100	150	200	250	300	350	400	450	500	550	600	650	700	750	800	850	900	950	1000	1050	1100	1150	1200	1250
L	506	556	606	656	706	756	806	856	906	956	1006	1056	1106	1156	1206	1256	1306	1356	1406	1456	1506	1556	1606	1656
A	50	100	150	200	50	100	150	200	50	100	150	200	50	100	150	200	50	100	150	200	50	100	150	200
M	1	1	1	1	2	2	2	2	3	3	3	3	4	4	4	4	5	5	5	5	6	6	6	6
N	6	6	6	6	8	8	8	8	10	10	10	10	12	12	12	12	14	14	14	14	16	16	16	16
KG	10.89	11.67	12.45	13.22	14	14.78	15.55	16.33	17.11	17.88	18.66	19.44	20.22	20.99	21.77	22.55	23.33	24.1	24.88	25.66	26.44	27.21	27.99	28.77

METS-17 Dimensions – Servo motor 400W



SLIDER ELECTRIC CYLINDER - BALL SCREW DRIVE (WITHOUT MOTOR)

mindman

BL

Motor on left side

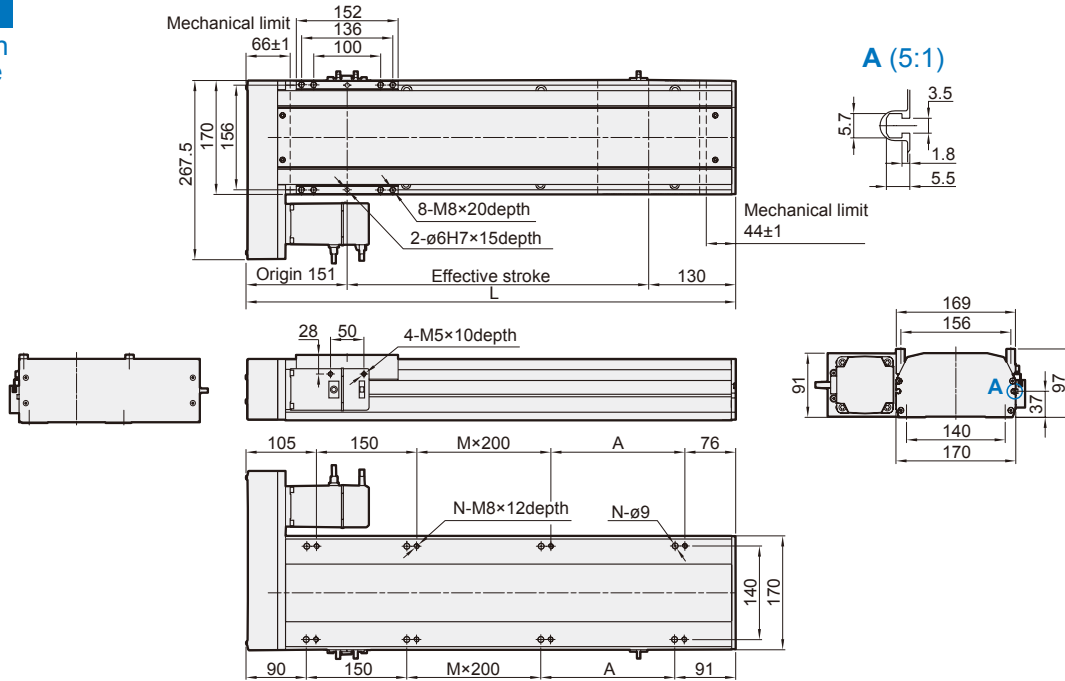

Unit: mm

Stroke	100	150	200	250	300	350	400	450	500	550	600	650	700	750	800	850	900	950	1000	1050	1100	1150	1200	1250
L	381	431	481	531	581	631	681	731	781	831	881	931	981	1031	1081	1131	1181	1231	1281	1331	1381	1431	1481	1531
A	50	100	150	200	50	100	150	200	50	100	150	200	50	100	150	200	50	100	150	200	50	100	150	200
M	0	0	0	0	1	1	1	1	2	2	2	3	3	3	3	4	4	4	4	4	5	5	5	5
N	6	6	6	6	8	8	8	8	10	10	10	10	12	12	12	12	14	14	14	14	16	16	16	16
KG	10.3	11.07	11.84	12.61	13.38	14.15	14.92	15.69	16.47	17.24	18.01	18.78	19.55	20.32	21.09	21.86	22.63	23.4	24.18	24.95	25.72	26.49	27.26	28.03

BR

Motor on right side

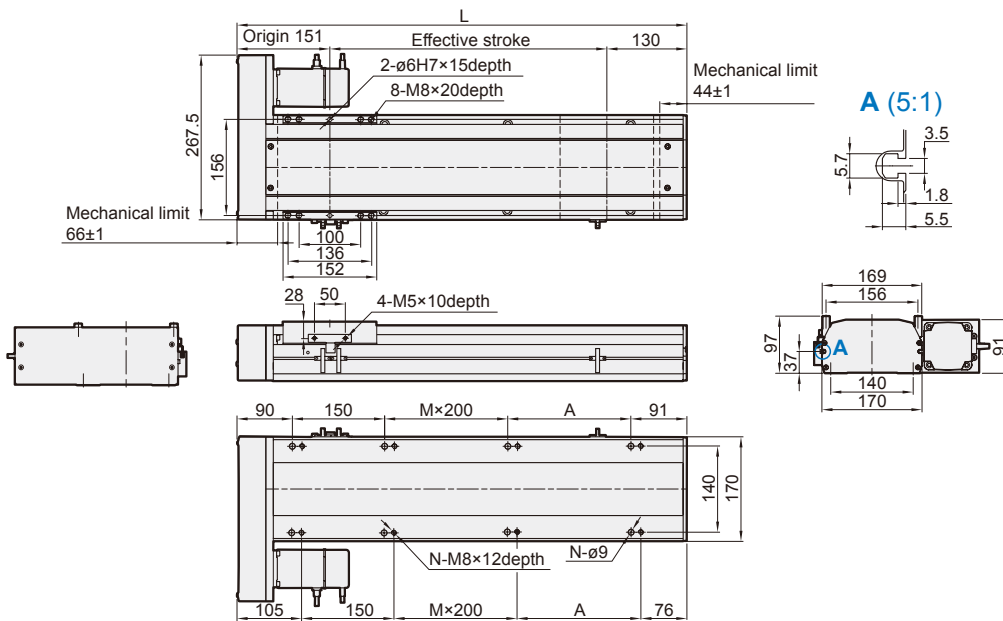

Unit: mm

Stroke	100	150	200	250	300	350	400	450	500	550	600	650	700	750	800	850	900	950	1000	1050	1100	1150	1200	1250
L	381	431	481	531	581	631	681	731	781	831	881	931	981	1031	1081	1131	1181	1231	1281	1331	1381	1431	1481	1531
A	50	100	150	200	50	100	150	200	50	100	150	200	50	100	150	200	50	100	150	200	50	100	150	200
M	0	0	0	0	1	1	1	1	2	2	2	2	3	3	3	3	4	4	4	4	5	5	5	5
N	6	6	6	6	8	8	8	8	10	10	10	10	12	12	12	12	14	14	14	14	16	16	16	16
KG	10.3	11.07	11.84	12.61	13.38	14.15	14.92	15.69	16.47	17.24	18.01	18.78	19.55	20.32	21.09	21.86	22.63	23.4	24.18	24.95	25.72	26.49	27.26	28.03

METS-17 Dimensions – Servo motor 400W



SLIDER ELECTRIC CYLINDER - BALL SCREW DRIVE (WITHOUT MOTOR)

Mindman

BM

Motor on lower side

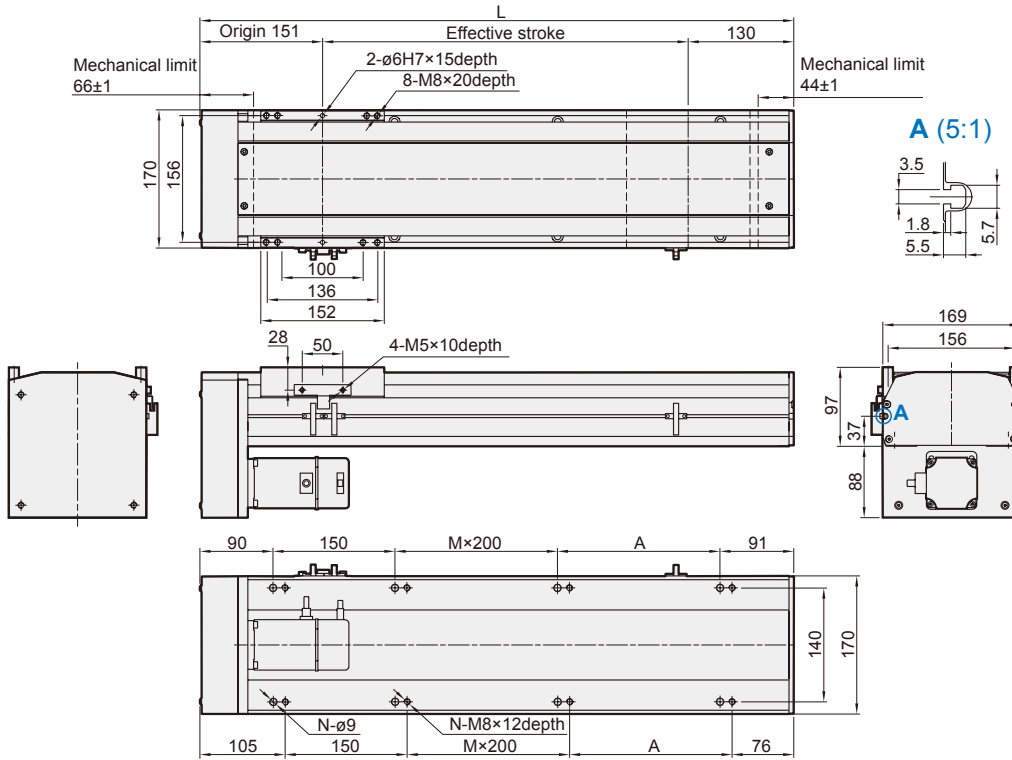

Unit: mm

Stroke	100	150	200	250	300	350	400	450	500	550	600	650	700	750	800	850	900	950	1000	1050	1100	1150	1200	1250
L	381	431	481	531	581	631	681	731	781	831	881	931	981	1031	1081	1131	1181	1231	1281	1331	1381	1431	1481	1531
A	50	100	150	200	50	100	150	200	50	100	150	200	50	100	150	200	50	100	150	200	50	100	150	200
M	0	0	0	0	1	1	1	1	2	2	2	2	3	3	3	3	4	4	4	4	5	5	5	5
N	6	6	6	6	8	8	8	8	10	10	10	10	12	12	12	12	14	14	14	14	16	16	16	16
KG	10.3	11.07	11.84	12.61	13.38	14.15	14.92	15.69	16.47	17.24	18.01	18.78	19.55	20.32	21.09	21.86	22.63	23.4	24.18	24.95	25.72	26.49	27.26	28.03

METS-17 Dimensions – Servo motor 750W



SLIDER ELECTRIC CYLINDER - BALL SCREW DRIVE (WITHOUT MOTOR)

BC

Motor exposed

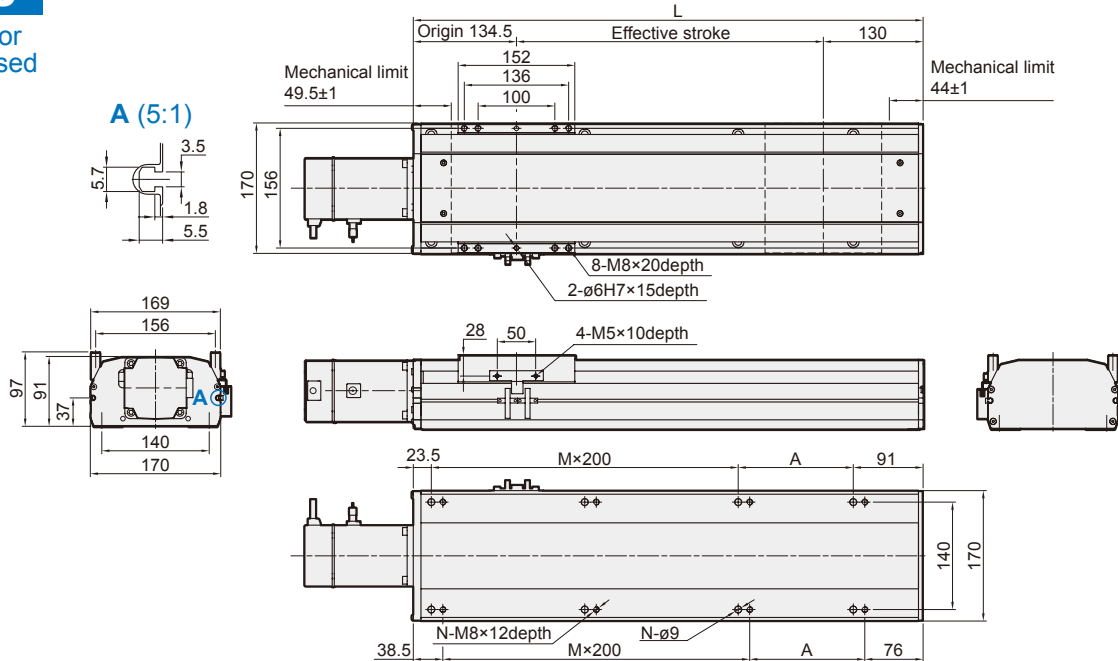

Unit: mm

Stroke	100	150	200	250	300	350	400	450	500	550	600	650	700	750	800	850	900	950	1000	1050	1100	1150	1200	1250
L	364.5	414.5	464.5	514.5	564.5	614.5	664.5	714.5	764.5	814.5	864.5	914.5	964.5	1014.5	1064.5	1114.5	1164.5	1214.5	1264.5	1314.5	1364.5	1414.5	1464.5	1514.5
A	50	100	150	200	50	100	150	200	50	100	150	200	50	100	150	200	50	100	150	200	50	100	150	200
M	1	1	1	1	2	2	2	2	3	3	3	3	4	4	4	4	5	5	5	5	6	6	6	6
N	6	6	6	6	8	8	8	8	10	10	10	10	12	12	12	12	14	14	14	14	16	16	16	16
KG	10.02	10.79	11.57	12.34	13.11	13.88	14.65	15.42	16.19	16.96	17.73	18.5	19.28	20.5	20.82	21.59	22.36	23.13	23.9	24.67	25.44	26.21	26.98	27.75

BM

Motor built-in

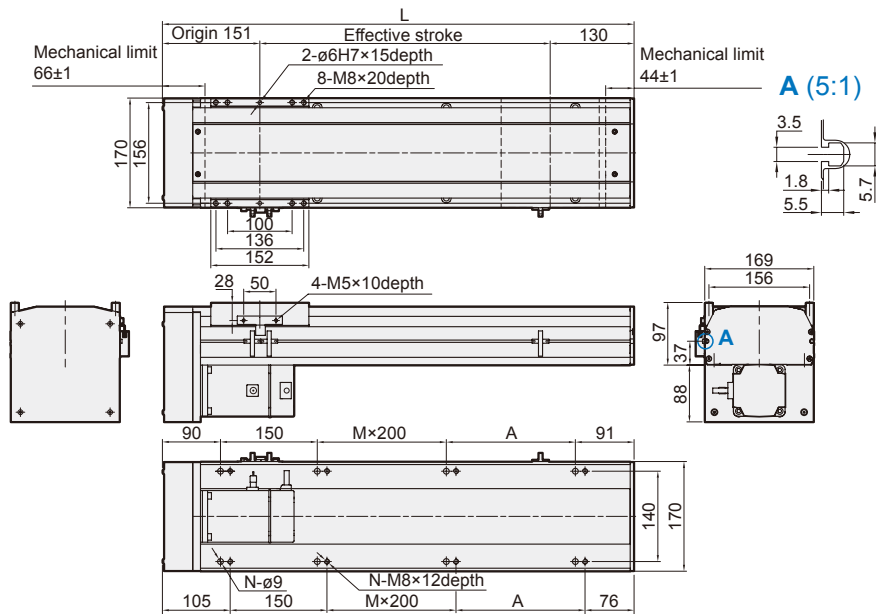

Unit: mm

Stroke	100	150	200	250	300	350	400	450	500	550	600	650	700	750	800	850	900	950	1000	1050	1100	1150	1200	1250
L	381	431	481	531	581	631	681	731	781	831	881	931	981	1031	1081	1131	1181	1231	1281	1331	1381	1431	1481	1531
A	50	100	150	200	50	100	150	200	50	100	150	200	50	100	150	200	50	100	150	200	50	100	150	200
M	0	0	0	0	1	1	1	1	2	2	2	2	3	3	3	3	4	4	4	4	5	5	5	5
N	6	6	6	6	8	8	8	8	10	10	10	10	12	12	12	12	14	14	14	14	16	16	16	16
KG	10.3	11.07	11.84	12.61	13.38	14.15	14.92	15.69	16.47	17.24	18.01	18.78	19.55	20.32	21.09	21.86	22.63	23.4	24.18	24.95	25.72	26.49	27.26	28.03

METS-17 Dimensions – Servo motor 750W



SLIDER ELECTRIC CYLINDER - BALL SCREW DRIVE (WITHOUT MOTOR)

mindman

BL

Motor on left side

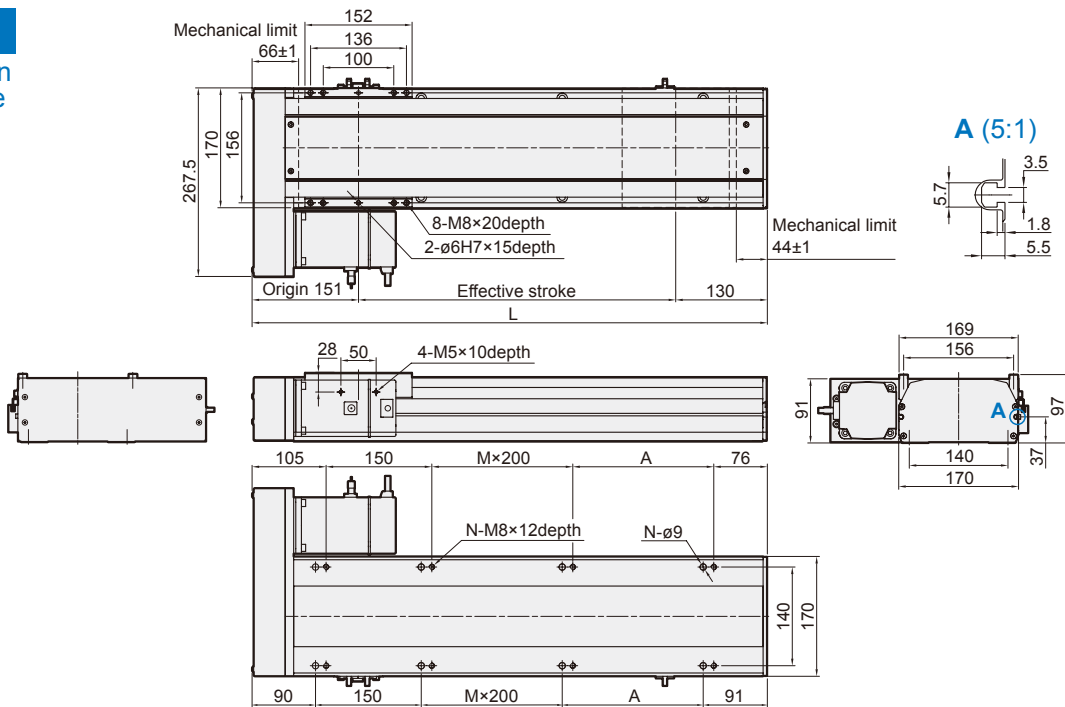

Unit: mm

Stroke	100	150	200	250	300	350	400	450	500	550	600	650	700	750	800	850	900	950	1000	1050	1100	1150	1200	1250
L	381	431	481	531	581	631	681	731	781	831	881	931	981	1031	1081	1131	1181	1231	1281	1331	1381	1431	1481	1531
A	50	100	150	200	50	100	150	200	50	100	150	200	50	100	150	200	50	100	150	200	50	100	150	200
M	0	0	0	0	1	1	1	1	2	2	2	2	3	3	3	3	4	4	4	4	5	5	5	5
N	6	6	6	6	8	8	8	8	10	10	10	10	12	12	12	12	14	14	14	14	16	16	16	16
KG	10.3	11.07	11.84	12.61	13.38	14.15	14.92	15.69	16.47	17.24	18.01	18.78	19.55	20.32	21.09	21.86	22.63	23.4	24.18	24.95	25.72	26.49	27.26	28.03

BR

Motor on right side

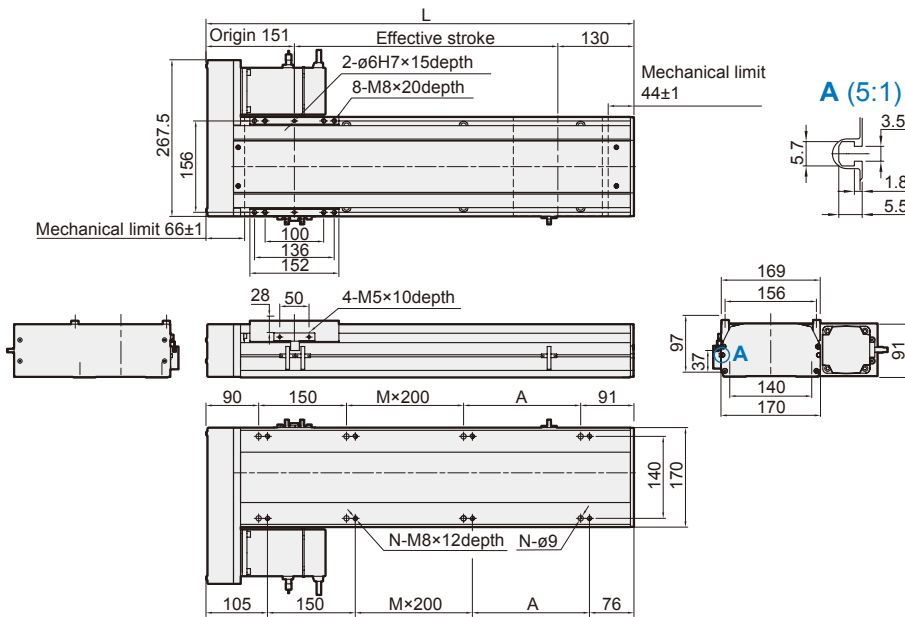

Unit: mm

Stroke	100	150	200	250	300	350	400	450	500	550	600	650	700	750	800	850	900	950	1000	1050	1100	1150	1200	1250
L	381	431	481	531	581	631	681	731	781	831	881	931	981	1031	1081	1131	1181	1231	1281	1331	1381	1431	1481	1531
A	50	100	150	200	50	100	150	200	50	100	150	200	50	100	150	200	50	100	150	200	50	100	150	200
M	0	0	0	0	1	1	1	1	2	2	2	2	3	3	3	3	4	4	4	4	5	5	5	5
N	6	6	6	6	8	8	8	8	10	10	10	10	12	12	12	12	14	14	14	14	16	16	16	16
KG	10.3	11.07	11.84	12.61	13.38	14.15	14.92	15.69	16.47	17.24	18.01	18.78	19.55	20.32	21.09	21.86	22.63	23.4	24.18	24.95	25.72	26.49	27.26	28.03