

METS-13 series



SLIDER ELECTRIC CYLINDER - BALL SCREW DRIVE (WITHOUT MOTOR)

Mindman



Specification

Model	METS-13				
Repeatability (mm)	±0.01				
Belt lead (mm)	5	10	16	20	
Max. speed	250	500	800	1000	
Servo motor	200W				
Max. payload (kg)	Horizontal	70	47	30	24
	Vertical	17	12	6	4
Rated thrust (N)	683	341	213	174	
Stroke (mm)	100~1050 / 50 pitch				
Ball screw ϕ (mm)	C7 ϕ 16				
High rigidity linear guide (mm)	W15×H12.5				
Coupling (mm)	10×14				
Home sensor	Outside	EE-SX672 (NPN)			
	Built in	EE-SX674 (NPN)			

Sensor layout

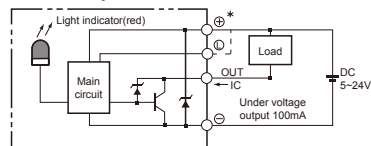

Order example

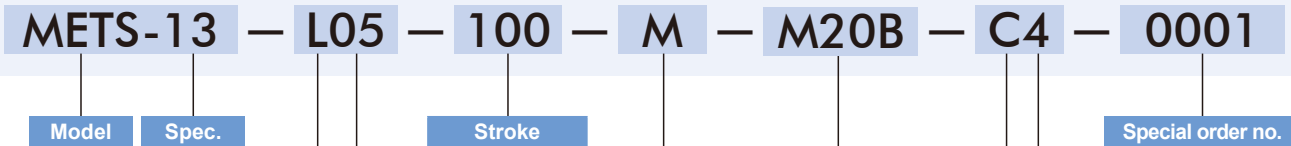

Ball screw brand	Ball screw lead	Motor position	Motor brand, power output, brakes	Home sensor	Limit sensor
L T-Standard MIT	05 5 mm	M Built-in	200W SERVO motor	In side	In side
	10 10 mm	BC Exposed	M Mitsubishi	A Motor side	1 1 Pc
	16 16 mm	BM On lower side	P Panasonic	B Opposite motor side	2 2 Pcs
	20 20 mm	BR On right side	Y Yaskawa	Out side	Out side
		BL On left side	T Delta	C Motor side	3 1 Pc
			20 200W B	D Opposite motor side	4 2 Pcs
				No sensor	No sensor
				E None	5 None

* Need not show B with no brake.

Allowable overhang

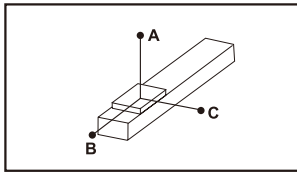

Unit: mm

Horizontal installation		A	B	C
Lead 5	40kg	2448	316	322
	55kg	2197	247	257
	70kg	2005	207	219
Lead 10	25kg	1958	370	490
	35kg	1660	370	333
	47kg	1725	247	243
Lead 16	10kg	1800	1400	800
	20kg	1100	700	450
	30kg	1047	445	324
Lead 20	5kg	2105	1351	960
	15kg	1170	455	420
	24kg	1300	250	305

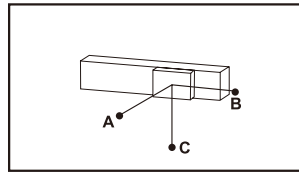

Unit: mm

Wall installation		A	B	C
Lead 5	40kg	204	112	1394
	55kg	130	57	1115
	70kg	85	24	895
Lead 10	25kg	414	333	1277
	35kg	235	157	929
	47kg	129	57	751
Lead 16	10kg	461	372	1410
	20kg	264	178	1027
	30kg	148	69	832
Lead 20	5kg	1041	965	1560
	15kg	400	271	770
	24kg	220	108	685

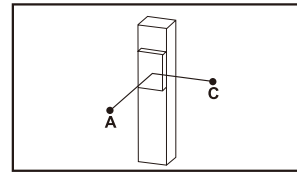

Unit: mm

Vertical installation		A	C
Lead 5	5kg	762	614
	10kg	607	489
	12kg	498	493
Lead 10	4kg	1365	1101
	6kg	901	727
	8kg	674	543
Lead 16	1kg	1067	1217
	2kg	997	805
	6kg	747	603
Lead 20	1kg	580	580
	2kg	1155	1155
	4kg	1130	885

Static loading moment

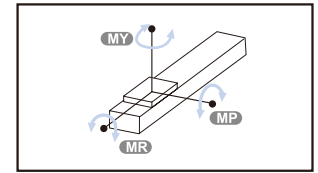

Unit: N.m

MY	174
MP	174
MR	153

Standard servo motors

Brand	Mark	Brake	Watt	AC-Voltage	Motor model	Compatible driver model
Mitsubishi	M	No brake(Horizontal type)	200	220	HF-KP23	MR-J3-20A
		With brake(Vertical type)	200	220	HF-KP23B	MR-J3-20A
Panasonic	P	No brake(Horizontal type)	200	220	MHMD022P1S	MADDT1207
		With brake(Vertical type)	200	220	MHMD022P1T	MADDT1207
Delta	T	No brake(Horizontal type)	200	220	ECMA-C20602ES	ASD-B20221-B
		With brake(Vertical type)	200	220	ECMA-C20602FS	ASD-B20221-B

METS-13 Dimensions – Servo motor 200W



SLIDER ELECTRIC CYLINDER - BALL SCREW DRIVE (WITHOUT MOTOR)

BC

Motor exposed

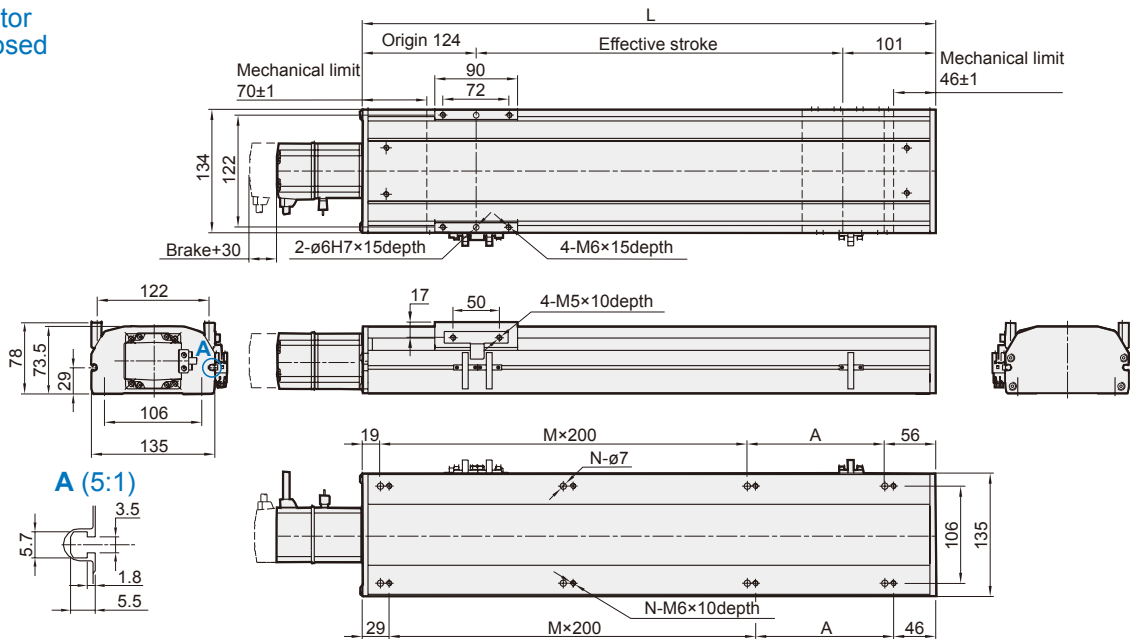

Unit: mm

Stroke	100	150	200	250	300	350	400	450	500	550	600	650	700	750	800	850	900	950	1000	1050
L	325	375	425	475	525	575	625	675	725	775	825	875	925	975	1025	1075	1125	1175	1225	1275
A	50	100	150	200	50	100	150	200	50	100	150	200	50	100	150	200	50	100	150	200
M	1	1	1	1	2	2	2	2	3	3	3	3	4	4	4	4	5	5	5	5
N	6	6	6	6	8	8	8	8	10	10	10	10	12	12	12	12	14	14	14	14
KG	7.96	8.52	9.08	9.64	10.2	10.76	11.32	11.88	12.44	13	13.56	14.12	14.68	15.24	15.8	16.36	16.92	17.48	18.04	18.6

M

Motor built-in

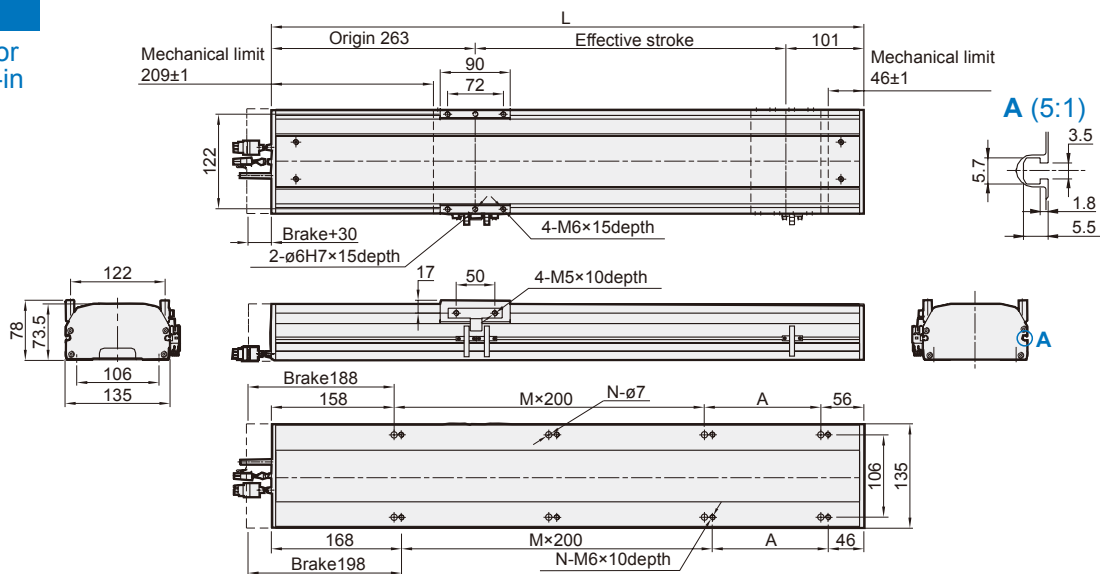

Unit: mm

Stroke	100	150	200	250	300	350	400	450	500	550	600	650	700	750	800	850	900	950	1000	1050
L	464	514	564	614	664	714	764	814	864	914	964	1014	1064	1114	1164	1214	1264	1314	1364	1414
A	50	100	150	200	50	100	150	200	50	100	150	200	50	100	150	200	50	100	150	200
M	1	1	1	1	2	2	2	2	3	3	3	3	4	4	4	4	5	5	5	5
N	6	6	6	6	8	8	8	8	10	10	10	10	12	12	12	12	14	14	14	14
KG	8.86	9.42	9.98	10.54	11.1	11.66	12.22	12.78	13.34	13.9	14.46	15.02	15.58	16.14	16.7	17.26	17.82	18.38	18.94	19.5

METS-13 Dimensions – Servo motor 200W



SLIDER ELECTRIC CYLINDER - BALL SCREW DRIVE (WITHOUT MOTOR)

mindman

BL

Motor on left side

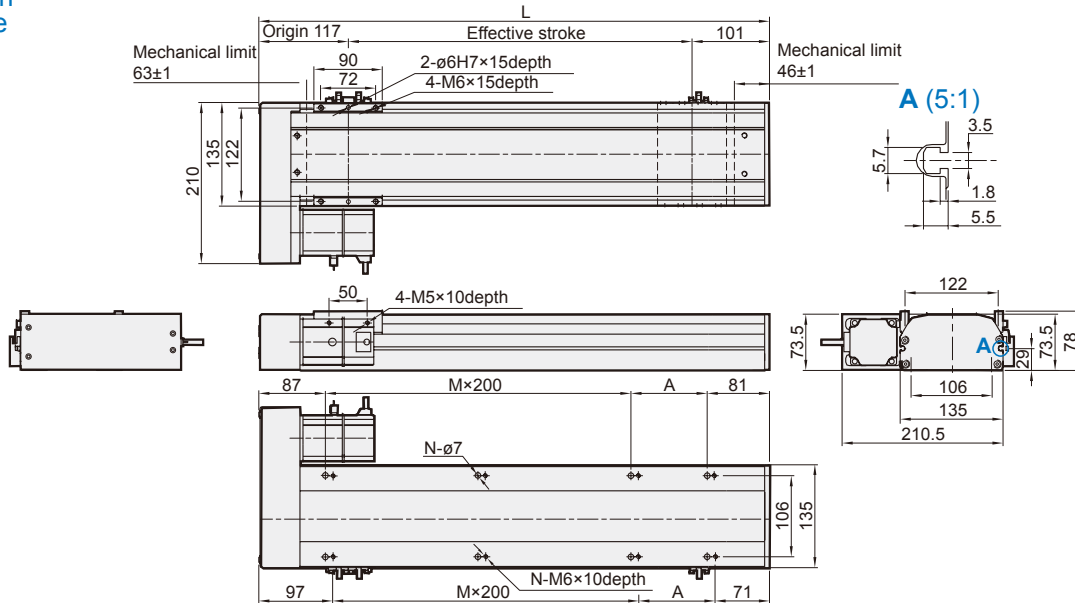

Unit: mm

Stroke	100	150	200	250	300	350	400	450	500	550	600	650	700	750	800	850	900	950	1000	1050
L	318	368	418	468	518	568	618	668	718	768	818	868	918	968	1018	1068	1118	1168	1218	1268
A	150	200	50	100	150	200	50	100	150	200	50	100	150	200	50	100	150	200	50	100
M	0	0	1	1	1	1	2	2	2	2	3	3	3	3	4	4	4	4	5	5
N	4	4	6	6	6	6	8	8	8	8	10	10	10	10	12	12	12	12	14	14
KG	8.5	9.06	9.62	10.18	10.74	11.3	11.86	12.42	12.98	13.54	14.1	14.66	15.22	15.78	16.34	16.9	17.46	18.02	18.58	19.14

BR

Motor on right side

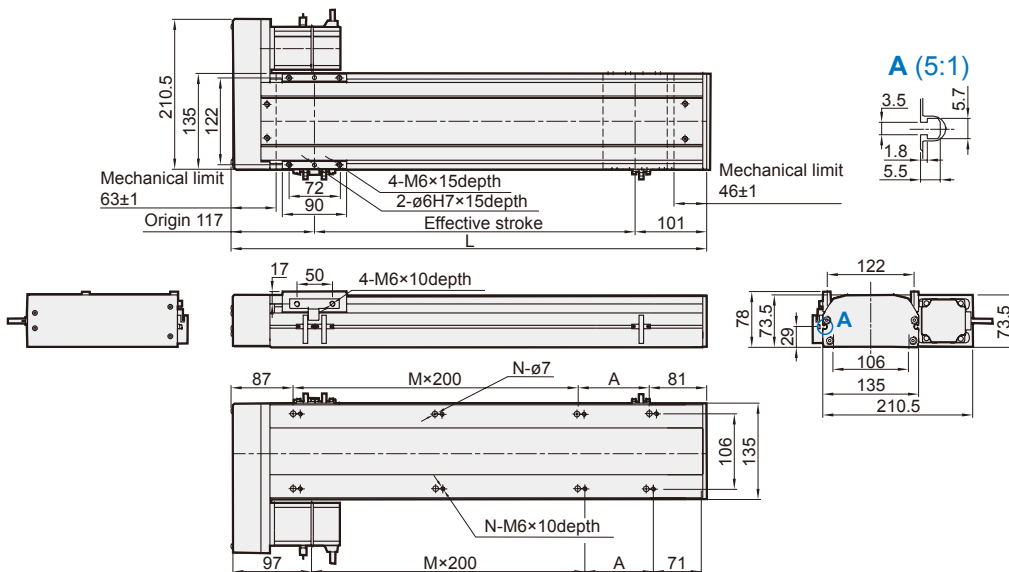

Unit: mm

Stroke	100	150	200	250	300	350	400	450	500	550	600	650	700	750	800	850	900	950	1000	1050
L	318	368	418	468	518	568	618	668	718	768	818	868	918	968	1018	1068	1118	1168	1218	1268
A	150	200	50	100	150	200	50	100	150	200	50	100	150	200	50	100	150	200	50	100
M	0	0	1	1	1	1	2	2	2	2	3	3	3	3	4	4	4	4	5	5
N	4	4	6	6	6	6	8	8	8	8	10	10	10	10	12	12	12	12	14	14
KG	8.5	9.06	9.62	10.18	10.74	11.3	11.86	12.42	12.98	13.54	14.1	14.66	15.22	15.78	16.34	16.9	17.46	18.02	18.58	19.14

METS-13 Dimensions – Servo motor 200W



SLIDER ELECTRIC CYLINDER - BALL SCREW DRIVE (WITHOUT MOTOR)

Mindman

BM

Motor on lower side

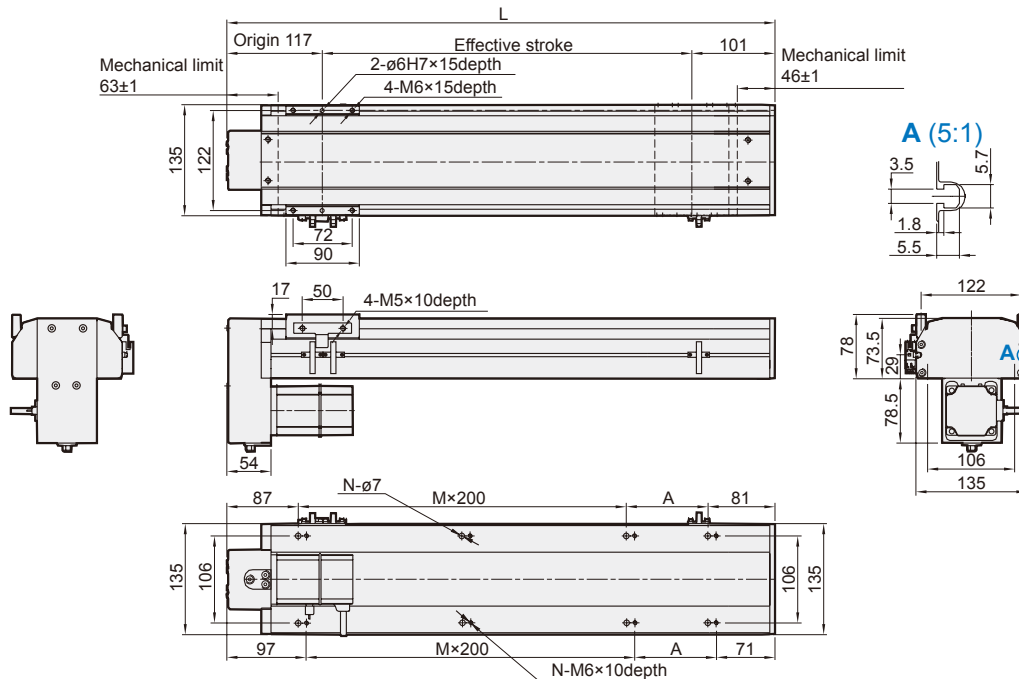

Unit: mm

Stroke	100	150	200	250	300	350	400	450	500	550	600	650	700	750	800	850	900	950	1000	1050
L	318	368	418	468	518	568	618	668	718	768	818	868	918	968	1018	1068	1118	1168	1218	1268
A	150	200	50	100	150	200	50	100	150	200	50	100	150	200	50	100	150	200	50	100
M	0	0	1	1	1	1	2	2	2	2	3	3	3	3	4	4	4	4	5	5
N	4	4	6	6	6	6	8	8	8	8	10	10	10	10	12	12	12	12	14	14
KG	8.5	9.06	9.62	10.18	10.74	11.3	11.86	12.42	12.98	13.54	14.1	14.66	15.22	15.78	16.34	16.9	17.46	18.02	18.58	19.14