

METS-10 series



SLIDER ELECTRIC CYLINDER - BALL SCREW DRIVE (WITHOUT MOTOR)

Mindman



Specification

Model	METS-10				
Repeatability (mm)	±0.01				
Belt lead (mm)	5	10	16	20	
Max. speed (mm/s)	250	500	800	1000	
Servo motor	100W				
Max. payload (kg)	Horizontal	50	30	22	18
	Vertical	12	8	5	3
Rated thrust (N)	341	170	106	85	
Stroke (mm)	100~1050 / 50 pitch				
Ball screw ϕ (mm)	C7 ϕ 16				
High rigidity linear guide (mm)	W20×H18				
Coupling (mm)	10×8				
Home sensor	Outside	EE-SX672 (NPN)			
	Built in	EE-SX674 (NPN)			

Sensor layout

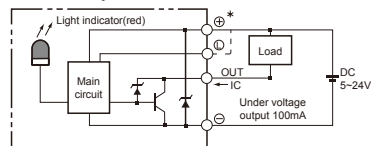

Order example

METS-10 — **L05** — **100** — **M** — **M10B** — **C4** — **0001**

Model Spec. Stroke Special order no.

100~1050 mm
50 mm pitch

Ball screw brand	Ball screw lead	Motor position	Motor brand, power output, brakes	Home sensor	Limit sensor
L T-Standard MIT	05 5 mm	M Built-in	100W SERVO motor	In side	In side
	10 10 mm	BC Exposed	M Mitsubishi	A Motor side	1 1 Pc
	16 16 mm	BM On lower side	P Panasonic	B Opposite motor side	2 2 Pcs
	20 20 mm	BR On right side	Y Yaskawa	Out side	Out side
		BL On left side	T Delta	C Motor side	3 1 Pc
			10 100W B	D Opposite motor side	4 2 Pcs
				No sensor	No sensor
				E None	5 None

* Need not show B with no brake.

Allowable overhang

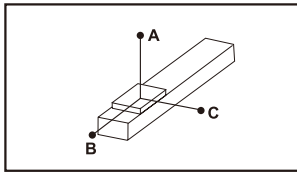

Unit: mm

Horizontal installation		A	B	C
Lead 5	30kg	424	24	25
	50kg	0	0	0
	-	-	-	-
Lead 10	15kg	394	76	79
	25kg	184	22	25
	30kg	111	-	-
Lead 16	5kg	937	282	259
	10kg	487	121	116
	22kg	236	40	44
Lead 20	5kg	940	285	264
	10kg	490	125	120
	15kg	240	45	48

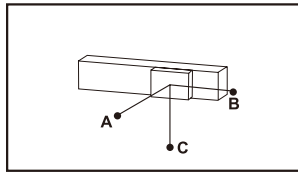

Unit: mm

Wall installation		A	B	C
Lead 5	10kg	105	50	1400
	20kg	22	0	538
	30kg	0	0	0
Lead 10	10kg	100	50	545
	20kg	20	0	221
	30kg	0	0	0
Lead 16	5kg	116	58	605
	10kg	24	0	253
	22kg	0	0	0
Lead 20	5kg	251	211	903
	10kg	97	49	436
	15kg	23	0	153

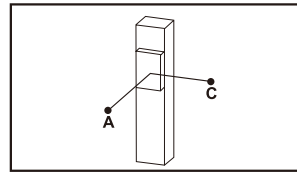

Unit: mm

Vertical installation		A	C
Lead 5	5kg	100	145
	10kg	50	90
	12kg	23	63
Lead 10	5kg	335	375
	6kg	140	180
	8kg	100	140
Lead 16	1kg	620	620
	2kg	680	680
	5kg	310	350
Lead 20	1kg	580	580
	2kg	645	645
	3kg	310	350

Static loading moment

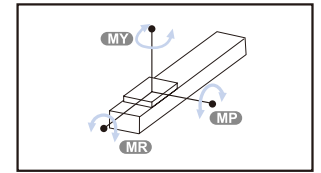

Unit: N.m

MY	110
MP	110
MR	120

Standard servo motors

Brand	Mark	Brake	Watt	AC-Voltage	Motor model	Compatible driver model
Mitsubishi	M	No brake(Horizontal type)	100	220	HP-KP13	MR-J3-10A
		With brake(Vertical type)	100	220	HP-KP13B	MR-J3-10A
Panasonic	P	No brake(Horizontal type)	100	220	MSMD012P1S	MADDT1205
		With brake(Vertical type)	100	220	MSMD012P1T	MADDT1205
Delta	T	No brake(Horizontal type)	100	220	ECMA-C20401ES	ASD-B20121-B
		With brake(Vertical type)	100	220	ECMA-C20401FS	ASD-B20121-B

METS-10 Dimensions – Servo motor 100W



SLIDER ELECTRIC CYLINDER - BALL SCREW DRIVE (WITHOUT MOTOR)

BC
Motor exposed

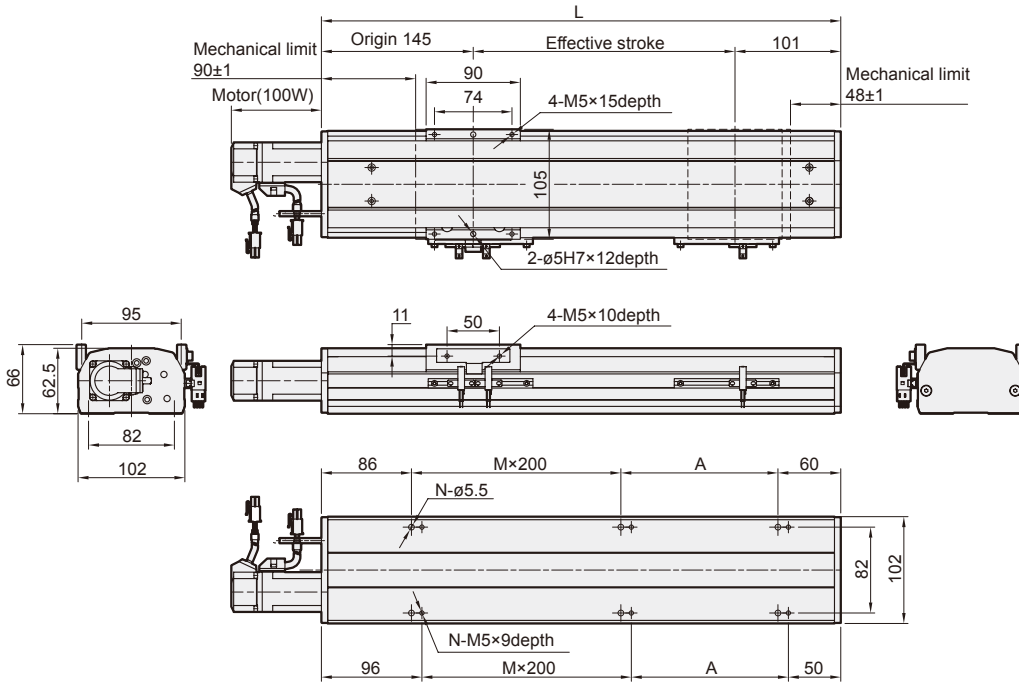

Unit: mm

Stroke	100	150	200	250	300	350	400	450	500	550	600	650	700	750	800	850	900	950	1000	1050
L	346	396	446	496	546	596	646	696	746	796	846	896	946	996	1046	1096	1146	1196	1246	1296
A	200	50	100	150	200	50	100	150	200	50	100	150	200	50	100	150	200	50	100	150
M	0	1	1	1	1	2	2	2	2	3	3	3	3	4	4	4	4	5	5	5
N	4	6	6	6	6	8	8	8	8	10	10	10	10	12	12	12	12	14	14	14
KG	4.64	5.02	5.41	5.79	6.18	6.56	6.95	7.33	7.72	8.1	8.49	8.87	9.26	9.64	10.03	10.41	10.8	11.18	11.57	11.95

M
Motor built-in

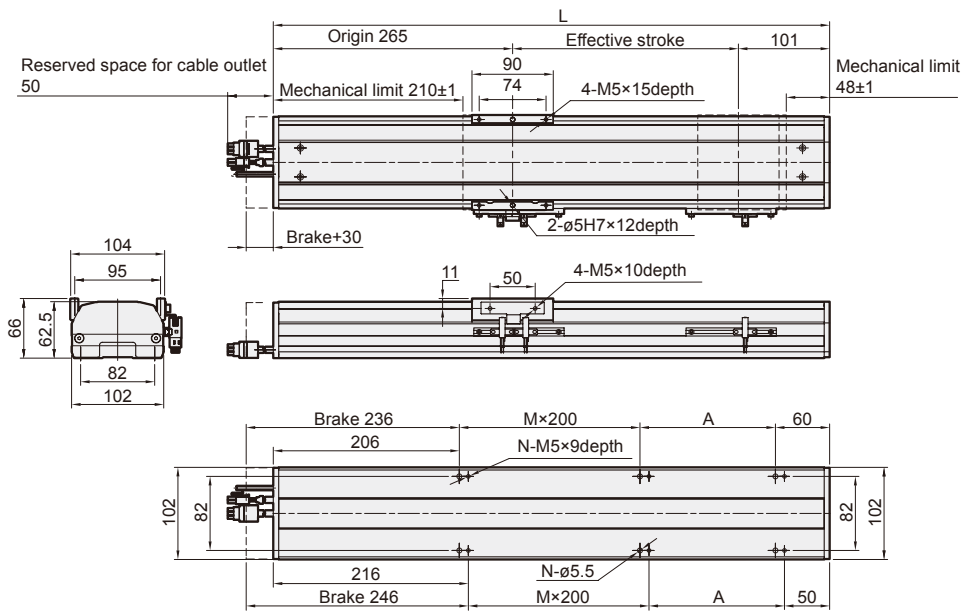

Unit: mm

Stroke	100	150	200	250	300	350	400	450	500	550	600	650	700	750	800	850	900	950	1000	1050
L	466	516	566	616	666	716	766	816	866	916	966	1016	1016	1166	1166	1216	1226	1316	1366	1416
A	200	50	100	150	200	50	100	150	200	50	100	150	200	50	100	150	200	50	100	150
M	0	1	1	1	1	2	2	2	2	3	3	3	3	4	4	4	4	5	5	5
N	4	6	6	6	6	8	8	8	8	10	10	10	10	12	12	12	12	14	14	14
KG	4.98	5.36	5.75	6.13	6.52	6.9	7.29	7.67	8.06	8.44	8.83	9.21	9.6	9.98	10.37	10.75	11.14	11.52	11.91	12.29

METS-10 Dimensions – Servo motor 100W



SLIDER ELECTRIC CYLINDER - BALL SCREW DRIVE (WITHOUT MOTOR)

mindman

BL

Motor on left side

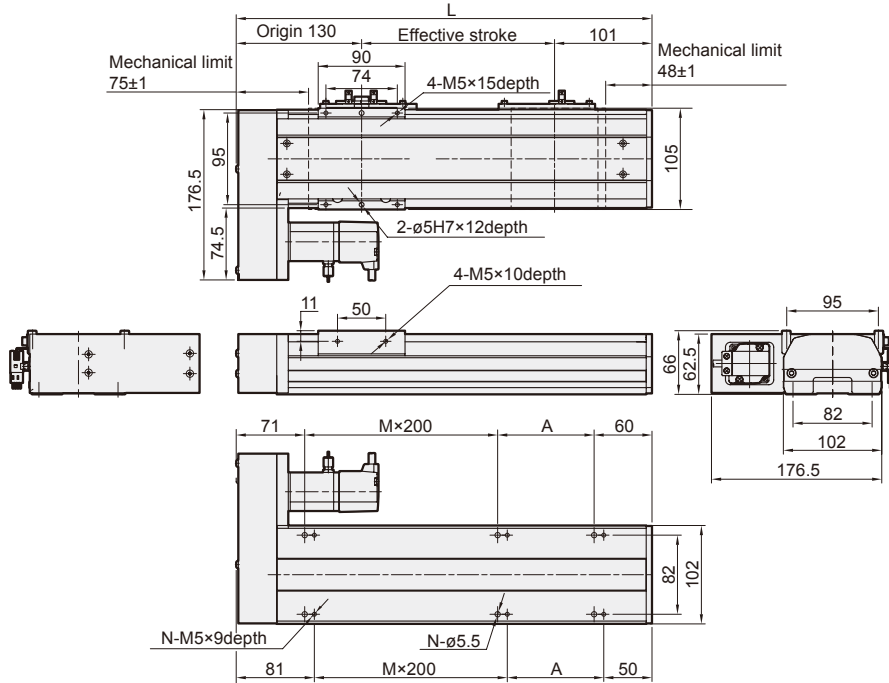

Unit: mm

Stroke	100	150	200	250	300	350	400	450	500	550	600	650	700	750	800	850	900	950	1000	1050
L	331	381	431	481	531	581	631	681	731	781	831	881	931	981	1031	1081	1131	1181	1231	1281
A	200	50	100	150	200	50	100	150	200	50	100	150	200	50	100	150	200	50	100	150
M	0	1	1	1	1	2	2	2	2	3	3	3	3	4	4	4	4	5	5	5
N	4	6	6	6	6	8	8	8	8	10	10	10	10	12	12	12	12	14	14	14
KG	4.86	5.25	5.63	6.02	6.4	6.79	7.17	7.56	7.94	8.33	8.71	9.1	9.48	9.87	10.25	10.64	11.02	11.41	11.79	12.18

BR

Motor on right side

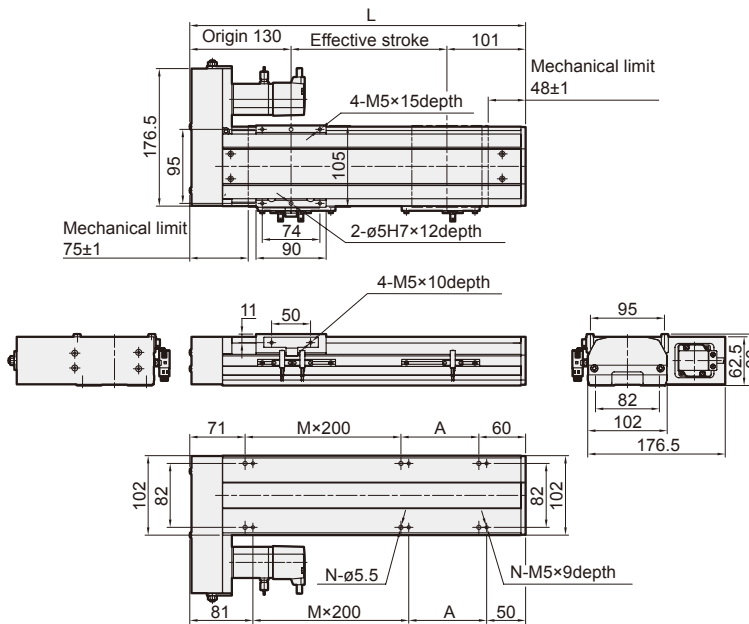

Unit: mm

Stroke	100	150	200	250	300	350	400	450	500	550	600	650	700	750	800	850	900	950	1000	1050
L	331	381	431	481	531	581	631	681	731	781	831	881	931	981	1031	1081	1131	1181	1231	1281
A	200	50	100	150	200	50	100	150	200	50	100	150	200	50	100	150	200	50	100	150
M	0	1	1	1	1	2	2	2	2	3	3	3	3	4	4	4	4	5	5	5
N	4	6	6	6	6	8	8	8	8	10	10	10	10	12	12	12	12	14	14	14
KG	4.86	5.25	5.63	6.02	6.4	6.79	7.17	7.56	7.94	8.33	8.71	9.1	9.48	9.87	10.25	10.64	11.02	11.41	11.79	12.18

METS-10 Dimensions – Servo motor 100W



SLIDER ELECTRIC CYLINDER - BALL SCREW DRIVE (WITHOUT MOTOR)

Mindman

BM

Motor on lower side

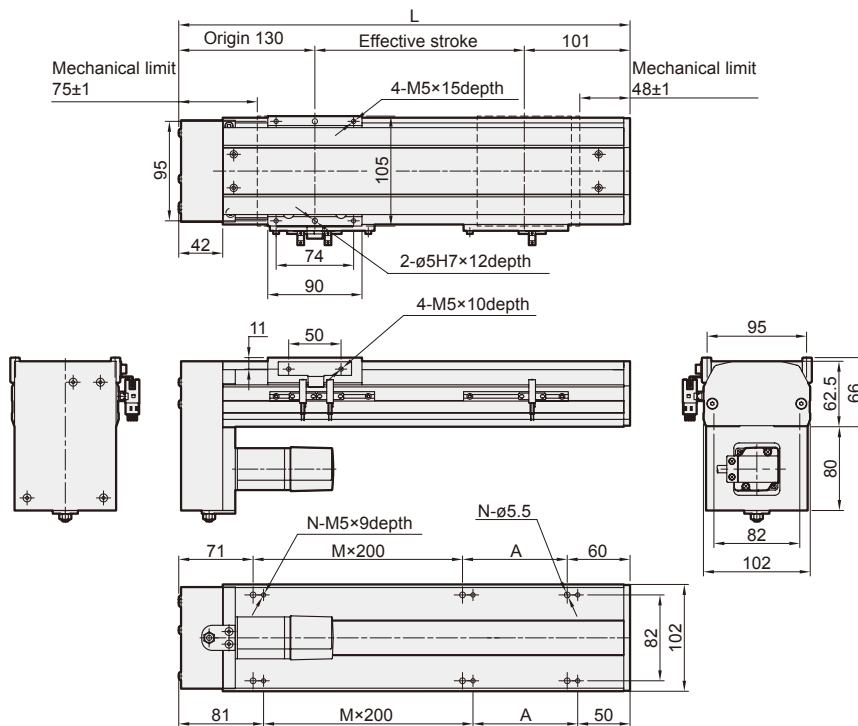

Unit: mm

Stroke	100	150	200	250	300	350	400	450	500	550	600	650	700	750	800	850	900	950	1000	1050
L	331	381	431	481	531	581	631	681	731	781	831	881	931	981	1031	1081	1131	1181	1231	1281
A	200	50	100	150	200	50	100	150	200	50	100	150	200	50	100	150	200	50	100	150
M	0	1	1	1	1	2	2	2	2	3	3	3	3	4	4	4	4	5	5	5
N	4	6	6	6	6	8	8	8	8	10	10	10	10	12	12	12	12	14	14	14
KG	4.86	5.25	5.63	6.02	6.4	6.79	7.17	7.56	7.94	8.33	8.71	9.1	9.48	9.87	10.25	10.64	11.02	11.41	11.79	12.18