

End lock type

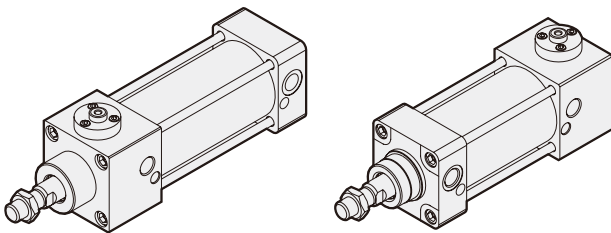

R: Rod cover

H: Head cover

Table for standard stroke

Tube I.D.	Stroke (mm)
ø63,80	50,75,100,125,150,175,200,250,300,350,400,450,500,600

- Stroke out of specification is also available.
- Please consult us if stroke out of specification.

Order example

MCQV2L — 11 — 63 — 100M — R

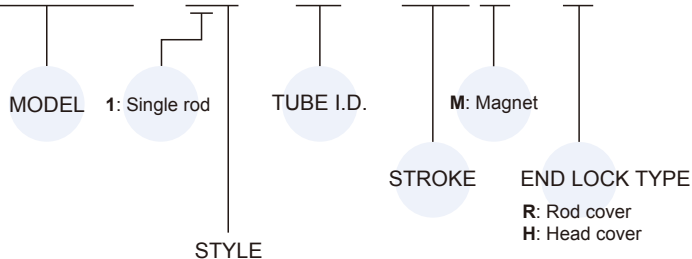

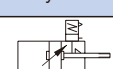
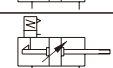
Code	Symbol	Description
1 1		Rod cover
		Head cover

* Order example for Rc or NPT thread please consult us.

Features

■ Non lubrication

Special housing and bushing enables self lubrication of piston rod.

■ High quality long service life

Hard anodised aluminium cylinder tubes offer a high resistance to corrosion and low internal friction.

■ ISO-VDMA standard specification

Conforms to ISO-6431 and VDMA 24562 specification enabling worldwide interchangeability.

Specification

Model	MCQV2L	
Tube I.D. (mm)	63	80
Medium	Air	
Operating perssure range	0.15~1 MPa	
Proof pressure	1.5 MPa	
Ambient temperature	-5~+60°C (No freezing)	
Available speed range	50~500 mm/sec	
Sensor switch (*)	RCA	
Sensor switch holder	HV2	HV3





* RCA specification, please refer to page 8-6.

Mounting accessories

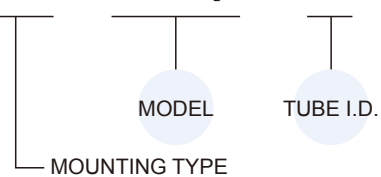
* Use the same accessories with MCQV.

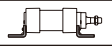
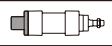
FAC — MCQV — 63

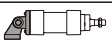
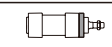
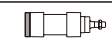
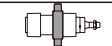
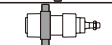
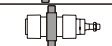

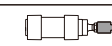
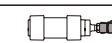
	LB
	CA
	CB
	CDB (+CB+PIN)
	FAC
	FBC
	TA
	TB
	TC
	Y
	I
	YS (Y+Floating+Pin)

END LOCK CYLINDER

Use recommended air pressure circuit

- The circuit layout must be settled properly. The recommended circuit design is shown below.

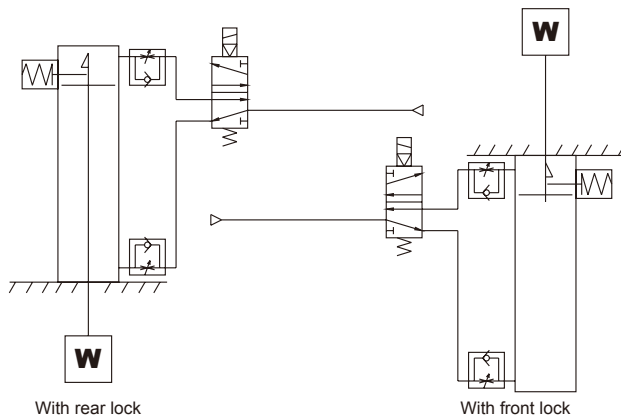

Maintains the cylinder's original position even if the air supply is interrupted.

Prevention of dropping at the rising end

With rear lock

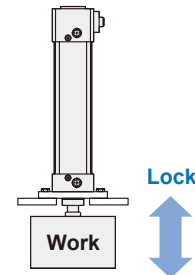

Locking of door With front lock

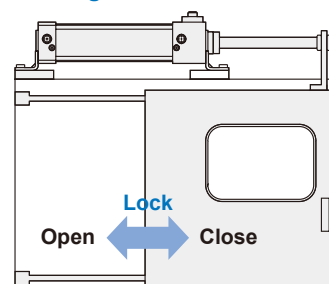

Precautions

- Do not use 3-way solenoid valves. The cylinder cannot be locked when compressed air is trapped in the lock side port. And the lock may be released due to the air leakage of solenoid valve, even it was locked successfully.
- Do not adjust or mount the cylinder when the lock is on.
- The operation load do not exceed 50% of the cylinder maximum output.
- Do not operate a workpiece with multiple end-lock cylinders simultaneously.
- Use an one-way speed control valve with meter-out circuit layout design. The lock cannot be released when the circuit layout is meter-in design.
- Operate the lock only when the cylinder is at the either end-position of stroke.
- The air supply must be higher than 0.15 MPa to operate the lock.
- The lock will be on when automatically when the pressure of the lock is lower than 0.1 MPa or less.
- There are many conditions that will cause the exhaust speed to reduce. The examples are shown below.
 - When the exhausting route length is too long.
 - When the one-way speed control valve is too far from cylinder port.
 - When the silencer of the solenoid valve is blocked or clogged.
- When the cushion needle is fully closed, the piston rod may not be able to reach the end of its stroke. When the cushion needle is fully closed and the cylinder is locked, the lock may not be able to be released.

END LOCK CYLINDER

Manual Lock Releasing

- 1 Install a bolt into the locking rod and pull it up by hands. When your hands release, the locking rod will move back by spring force and continue locking.

The bolt size, inner spring pulling force and the stroke of locking rod are listed below.

MODEL	Thread size	Pulling force	Stroke (mm)
MCQV2L-63	M6×1.0×20 ℓ	24.5 N	4
MCQV2L-80	M6×1.0×20 ℓ	24.5 N	5

- 2 The bolt must be uninstalled after manual lock releasing, or the weight of bolt may cause some performance problems of the lock.

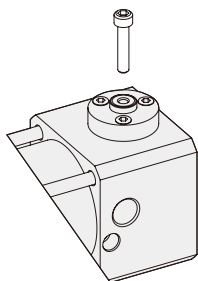

Installation of sensor switch

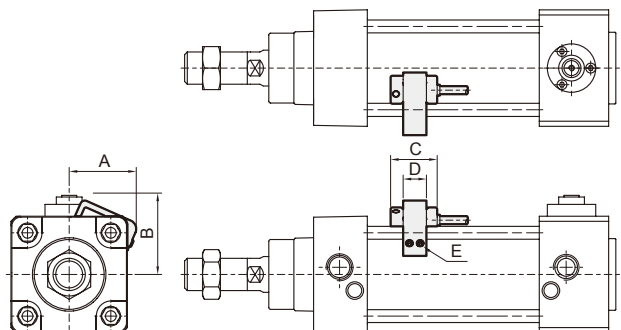
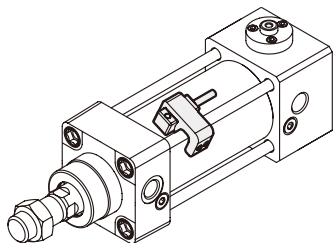

Code Tube I.D.	Sensor switch	Hold	A	B	C	D	E
63	RCA	HV2	42.5	50	26	13	M4×10L
80	RCA	HV3	49.5	60	26	13	M4×10L

Working Principle

- Both front locking type and rear locking type have the same mechanism. The pictures below shows that how a rear locking type cylinder works.

- 1 When the air pressure is input from front cap, the piston will move backward. After the piston nears the end of the stroke, the slope of chamfered rod (the position of *mark) will touch the locking rod.

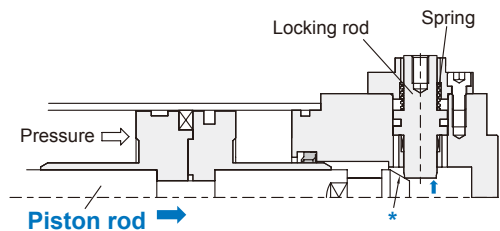

- 2 The locking rod will be guided with the slope and keeps moving upward.

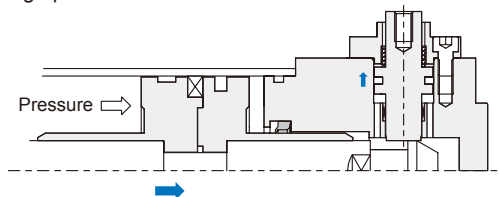

- 3 The locking rod will be pushed into the locking slot of the piston rod by the spring force. At this time, the cylinder is locked.

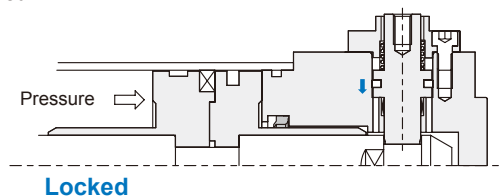

- 4 When the air pressure is input from rear cap, the piston will start moving forward. At the same time, the locking rod will be pushed up by the compressed air and make the piston rod unlocked.

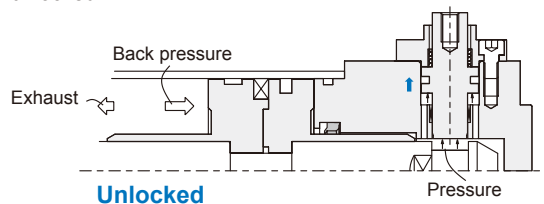

- 5 As the locking rod is no longer locking the piston rod, the cylinder can move forward.

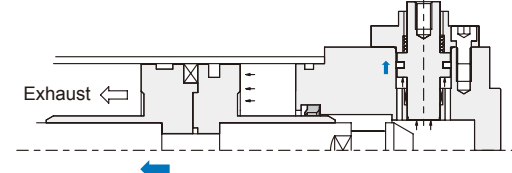

R

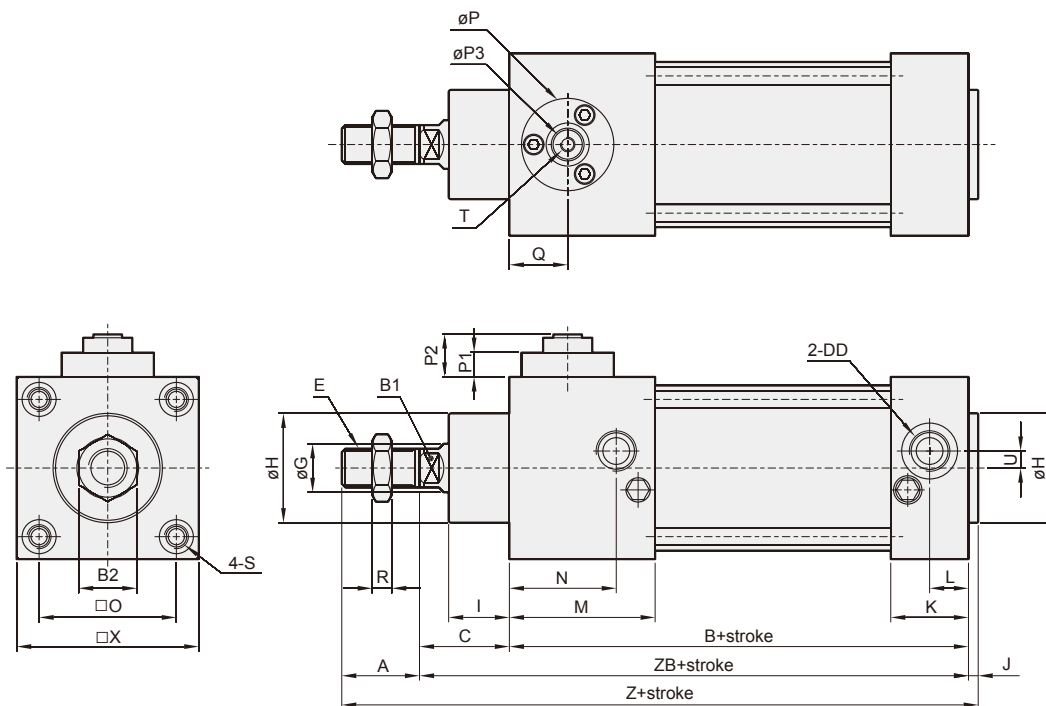

H

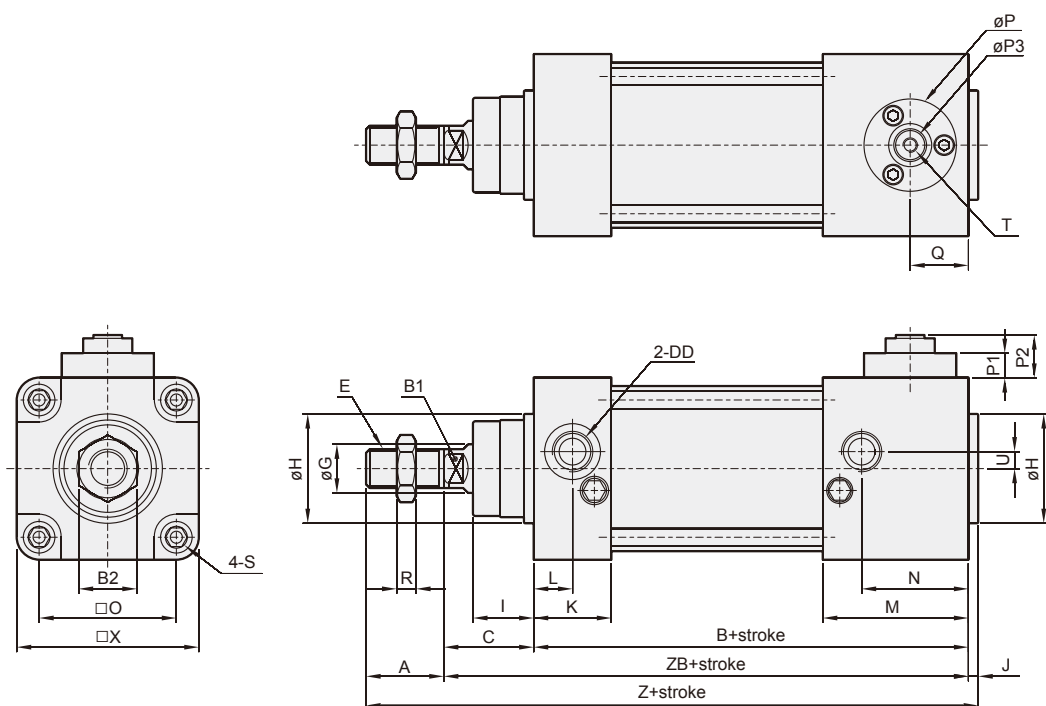

Code Tube I.D.	A	B	B1	B2	C	DD	E	G	H	I	J	K	L	M	N	O	P	P1	P2	P3	Q	R
63	32	149	16	24	37	G3/8	M16×1.5	20	45	26	4	33	16	61	44	56.5	40	14	24	12	24	8
80	40	168	21	30	46	G3/8	M20×1.5	25	45	32.5	4	35.5	20.5	75.5	60.5	72	50	12	16	14	26	10

Code Tube I.D.	S	T	U	X	Z	ZB
63	M8×1.25	M6×1.0	8	78	222	186
80	M10×1.5	M6×1.0	9	95	258	214