



Table for standard stroke

Unit: mm

Tube I.D.	Standard type	End-plain
ø6	5, 10, 15, 20, 25	5, 10, 15, 20
ø10	5, 10, 15, 20, 25, 30	5, 10, 15, 20
ø16	5, 10, 15, 20, 25, 30, 40	5, 10, 15, 20, 25



* It can't be supplied if the stroke is out of the maximum of above table.

Order example

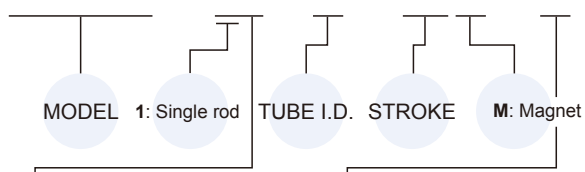

MCMJP — 11 — 6 — 10M — E



STYLE

Code	Symbol	Description
1 1		Double acting / Male thread
1 8		Double acting / Threadless

TYPE

Code	Symbol	Description
Blank		Standard type
E		End-plain

Features

- Space saving, compact design enables simple mounting.
- Flush fitting sensor switch.

Specification

Model	MCMJP		
Acting type	Double acting		
Tube I.D. (mm)	6	10	16
Port size	M3×0.5		M5×0.8
Medium	Air		
Max. operating pressure	0.7 MPa		
Min. operating pressure	0.12 MPa	0.06 MPa	
Proof pressure	1 MPa		
Lubrication	Not required		
Ambient temperature	-5~+60°C (No freezing)		
Available speed range	50~500 mm/sec		
Max. allowable kinetic energy	0.012J	0.025J	0.05J
Sensor switch (*)	RDF, RDGV		



* RDF, RDGV specification, please refer to page 8-15, 16.

Mounting accessories

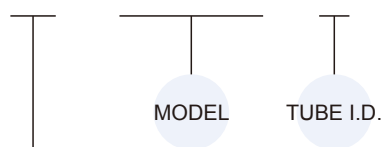
FA — MCMJP — 6



MOUNTING TYPE

	LB
	FA
	SDB

Installation of sensor switch

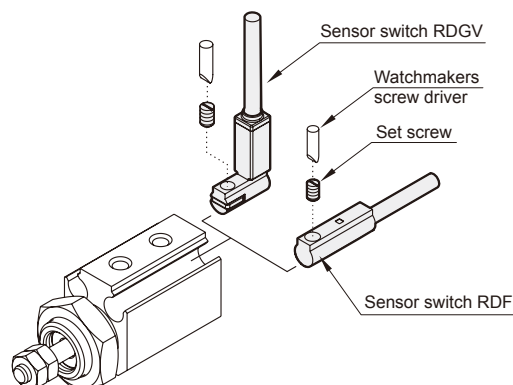

PEN CYLINDER

$\phi 6, \phi 10$

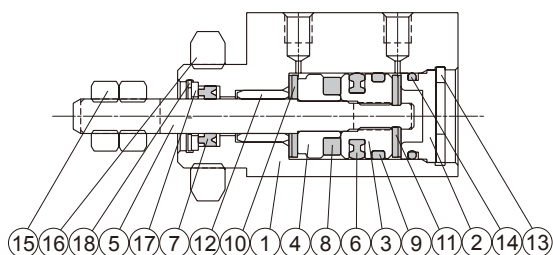

$\phi 16$

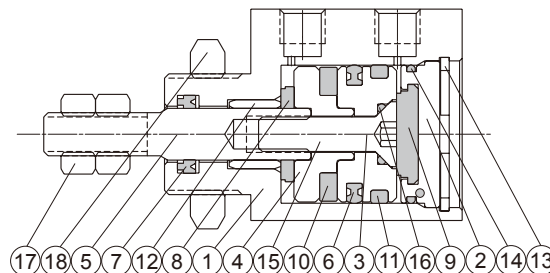

Material

No.	Part name	Material	Note
1	Body	Aluminum alloy	
2	End cover	Aluminum alloy	
3	Piston	Aluminum alloy	
4	Piston	Aluminum alloy	for with magnet
5	Piston rod	Stainless steel	
6	Piston packing	NBR	
7	Rod packing	NBR	
8	Magnet ring	Magnet material	for with magnet
9	Wear ring	Teflon	
10	Cushion	NBR	
11	Cushion	NBR	
12	Rod bush	Copper	
13	Stop ring	Carbon steel	
14	Cover ring	NBR	
15	Rod front nut	Copper	
16	Tie nut	Carbon steel	
17	Fixed ring	Aluminum alloy	
18	Stop ring	Carbon steel	

No.	Part name	Material	Note
1	Body	Aluminum alloy	
2	End cover	Aluminum alloy	
3	Piston	Aluminum alloy	
4	Piston	Aluminum alloy	for with magnet
5	Piston rod	Stainless steel	
6	Piston packing	NBR	
7	Rod packing	NBR	
8	Cushion	NBR	
9	Cushion	NBR	
10	Magnet ring	Magnet material	for with magnet
11	Wear ring	Teflon	
12	Rod bush	Copper	
13	Stop ring	Carbon steel	
14	Cover ring	NBR	
15	Piston bolt	SCM	
16	Piston gasket	NBR	
17	Rod front nut	Copper	
18	Tie nut	Carbon steel	

Cylinder weight

Unit: g

Stroke (mm)	11: Male thread			18: Threadless		
	$\phi 6$	$\phi 10$	$\phi 16$	$\phi 6$	$\phi 10$	$\phi 16$
5	19	29	46	18	28	45
10	21	31	50	20	30	49
15	24	34	54	23	33	53
20	26	36	58	25	35	57
25	29	39	62	28	38	61
30	—	41	66	—	40	65
40	—	—	74	—	—	73

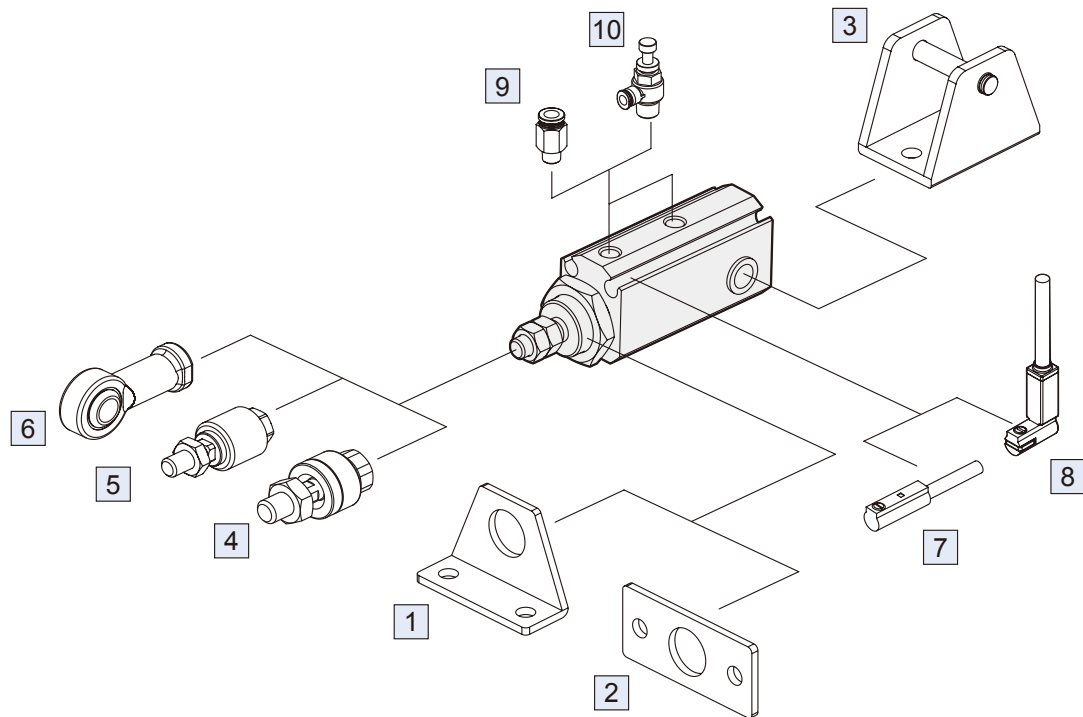

No.	Accessories	Page
1	Mounting accessories LB	3-68
2	Mounting accessories FA	3-68
3	Mounting accessories SDB+PIN	3-67, 68
4	Floating joint MFC	8-2
5	Floating joint MFCS	8-4
6	Female rod ends PHS	8-5
7	Sensor switch RDF	8-15
8	Sensor switch RDGV	8-16
9	Fitting PC (PISCO)	8-5 (Vol.1)
10	Speed controller JSC (PISCO)	8-18 (Vol.1)

PEN CYLINDER

Mindman

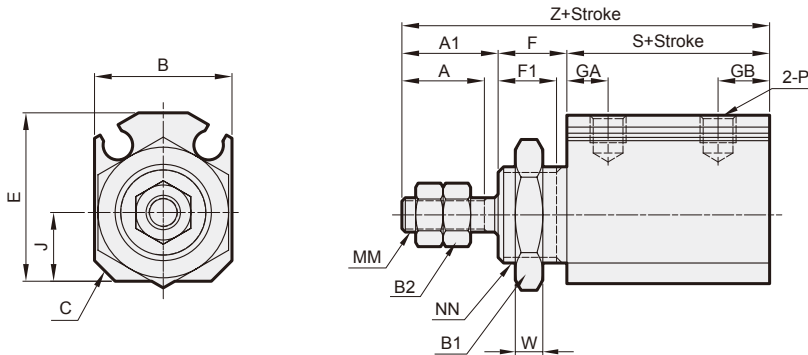

MCMJP-18

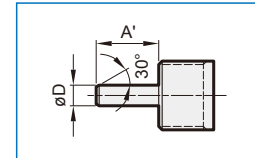

Code Tube I.D.	A	A1	B	B1	B2	C	D	E	F	F1	GA	GB	J	MM	NN	P	W	Without magnet		Magnet	
	S	Z	S	Z																	
6	7	9	14	14	5.5	2	3	16.5	8	6.5	5.5	6	6	M3×0.5	M10×1.0	M3×0.5	4	16	33	21	38
10	10	12	15	17	7	2.5	4	19	8	6.5	6	7	7	M4×0.7	M12×1.0	M3×0.5	4	19.5	39.5	24.5	44.5
16	12	14	20	19	8	3	6	24.5	10	8.5	6	7.5	10	M5×0.8	M14×1.0	M5×0.8	4	19.5	43.5	24.5	48.5

E

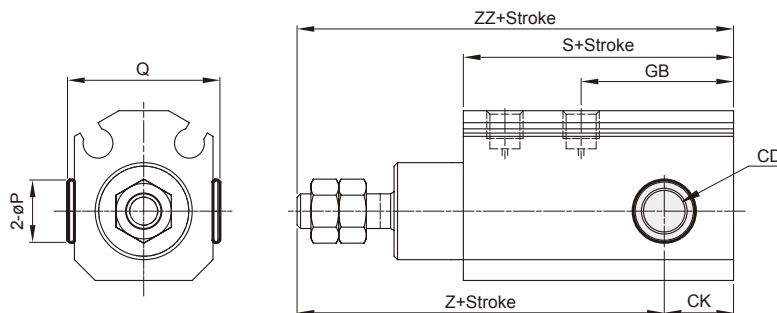

Code Tube I.D.	CD	CK	GB	P	Q	Without magnet			Magnet		
						S	Z	ZZ	S	Z	ZZ
6	3 ^{+0.04} ₊₀	4	11	—	—	21	34	38	26	39	43
10	5 ^{+0.06} ₊₀	6.5	18	8	17	30.5	44	50.5	35.5	49	55.5
16	6 ^{+0.06} ₊₀	10	22	9	22	34	48	58	39	53	63

PIN

Order example

PIN — MCMJP — 10 — SDB — P

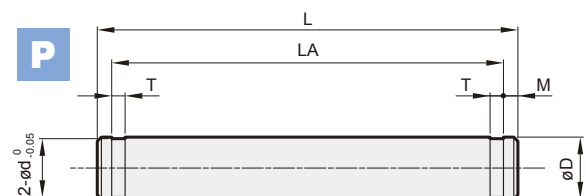
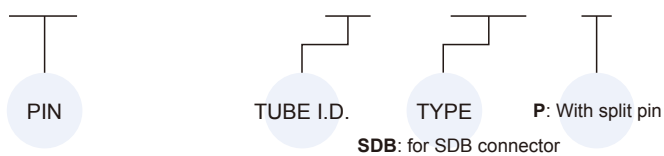

Code Tube I.D.	D ^{ø9}	d	L	LA	M	T	Split pin
6	3 ^{-0.02} _{-0.05}	2.85	20.4	19	0.7	0.5	STW-3
10	5 ^{-0.03} _{-0.06}	4.8	23.9	21.9	1	0.7	STW-5
16	6 ^{-0.03} _{-0.06}	5.7	31.9	29.9	1	0.8	STW-6

LB

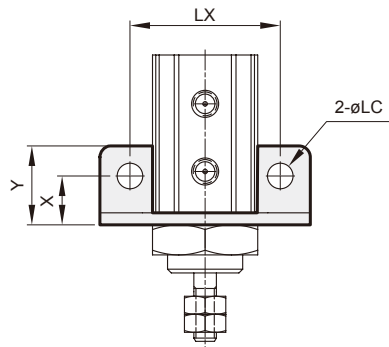

Code Tube I.D.	LC	LH	LT	LW	LX	LZ	X	Y
6	3.4	11	1.6	21.5	20	28	6.5	10.5
10	4.5	13	1.6	25	24	33	7	12
16	5.5	18	2.3	32.5	30	43	10	16.5

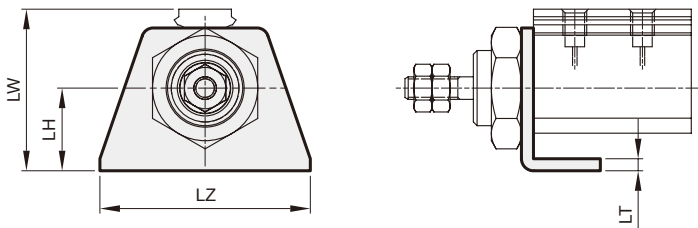

FA

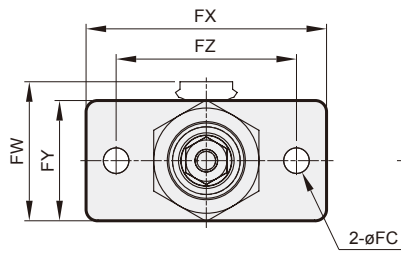

Code Tube I.D.	FC	FT	FW	FX	FY	FZ
6	3.4	1.6	18.5	24	16	32
10	4.5	1.6	21	28	18	37
16	5.5	2.3	25.5	36	22	49

SDB

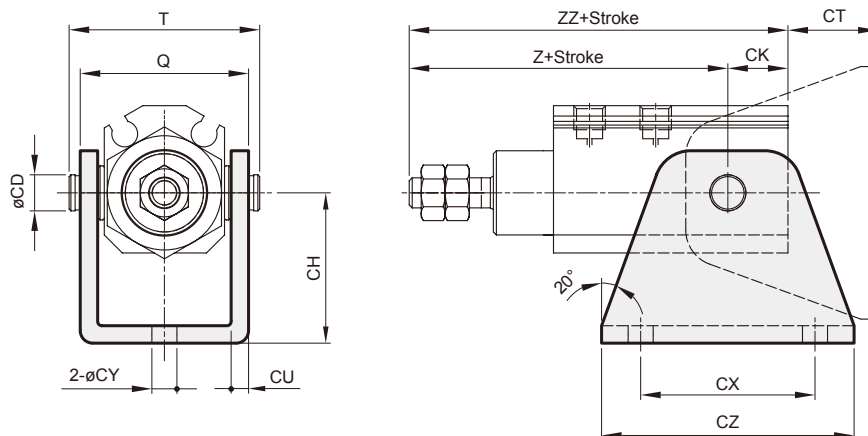

Code Tube I.D.	CD	CH	CK	CT	CU	CX	CY	CZ	Q	T	Without magnet		Magnet	
											Z	ZZ	Z	ZZ
6	3	16	4	12	1.6	18	3.4	26	18.5	20.4	34	38	39	43
10	5	20	6.5	13.5	1.6	24	4.5	33	20.5	23.9	44	50.5	49	55.5
16	6	25	10	15	3	29	5.5	42	28.2	31.9	48	58	53	63