

Features

■ Non lubrication

Special housing and bushing enables self lubrication of piston rod.

■ High quality long service life

Hard anodised stainless steel cylinder tubes offer a high resistance to corrosion and low internal friction.

■ Cylinder mountings

Available with a comprehensive range of accessories for rigid or flexible mounting.

■ ISO-6432 standard

Enables world-wide inter-changeability.

■ Port thread Rc. NPT. are also available

■ Magnetic as standard

Table for standard stroke

	Tube I.D.	Stroke (mm)
Single acting	ø16	15,25,50,75,100
	ø20,25	15,25,50,75,100,125,150
Double acting	ø8,10	10,25,40,50,80,100
	ø12	10,25,40,50,80,100,125,160,200
	ø16,20,25	15,25,50,75,100,125,150,200,250,300,350,400,450,500

* Stroke out of specification is also available.

* Please consult us if stroke out of specification.

Tightening torque

Tube I.D.	Rod thread	Tightening torque (kgf-cm)	Tube I.D.	Rod thread	Tightening torque (kgf-cm)
ø8	M4×0.8	11.8	ø16	M6×1.0	41
ø10	M4×0.8	11.8	ø20	M8×1.25	170
ø12	M6×1.0	41	ø25	M10×1.25	340

* Make sure the tightening torque of rod thread does not exceed the value above.

* The tolerance of tightening torque is ±5%.

Model	MCFI					
Tube I.D. (mm)	8	10	12	16	20	25
Port size	M5×0.8			G1/8		
Medium	Air					
Max. operating pressure	0.7 MPa					
Min. operating pressure(MPa)	0.1	0.08		0.06		
Proof pressure	1 MPa					
Lubricator	Not required					
Ambient temperature	-5~+60°C (No freezing)					
Available speed range	50~500 mm/sec					
Max. allowable kinetic energy (J)	Cushion pad	0.02	0.03	0.04	0.09	0.27
	Cushion air	—	—	—	0.4	0.66
Sensor switch (*)	RCM					
Sensor switch (band)	BM8	BM10	BM12	BM16	BM20	BM25

* RCM specification, please refer to page 8-13.

Order example

MCFI - 11 - 16 - 100 - A - N

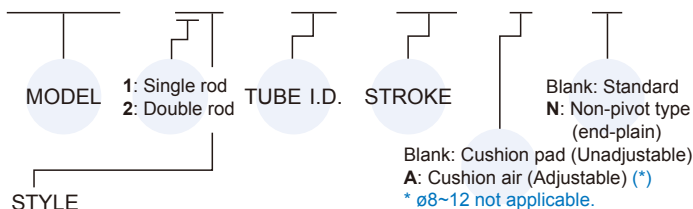

Code	Symbol	Description
1 1		Double acting / Male thread
1 3		Single acting / Normally extended male thread
1 5		Single acting / Normally returned male thread
2 1		Double rod / Male thread
2 7		Double rod / Adjustable male thread Please mark "adjustable distance(mm)" at order list

* Single acting type, please consult us.

* Order example for special specification, refer to page 0-7.

Mounting accessories

LB - MCFI - 16

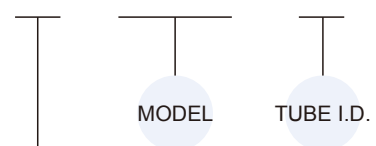

MOUNTING TYPE

	LB
	FA
	FB
	SDB
	Y
	I
	YS (Y=Floating pin)

* Y, I, YS, please refer to page 3-13.

ø8, ø12

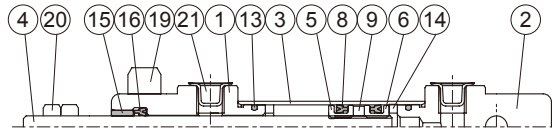

ø10

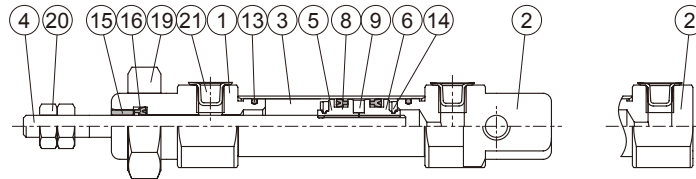

N type: ø8~ø25

ø16, ø20

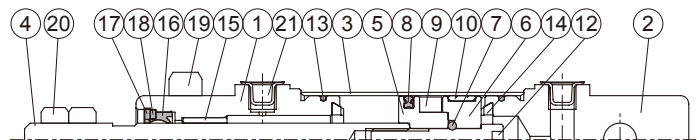

15 type: ø16

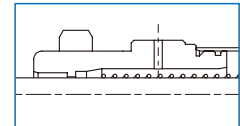

ø25

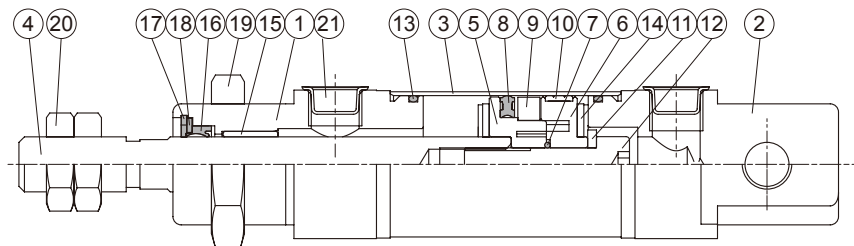

Material

* Style 21 is not applicable in cylinder bore ø8~ø12.
* Repair kit is not applicable for cylinder bore ø8~ø12.

No.	Tube I.D. Part name	8	10	12	16	20	25	Q'ty		Component parts (inclusion)		Repair kits (inclusion)
								11 type	21 type	11 type	21 type	
1	Rod cover	Aluminum alloy					1	2	●	●		
2	Head cover	Aluminum alloy					1	—	●			
3	Tube	Stainless steel					1	1				
4	Piston rod	Stainless steel						*2	1	1		
5	Piston-R	Aluminum alloy						*1	1	1	●	●
6	Piston-H	Aluminum alloy						*1	1	1	●	●
7	Piston gasket	—					NBR		1	1	●	●
8	Piston packing	—					NBR		1*3	1*3	●	●
9	Magnet ring	—					Magnet material		1	1	●	●
10	Wear ring	—					Teflon+Graphite		1	1	●	●
11	Washer	—						*2	1	—	●	
12	Piston bolt	—					SCM		1	—	●	
13	Cover ring	—					NBR		2	2	●	●
14	Cushion gasket	—					NBR		2	2	●	●
15	Rod bush	—					Bearing alloy		1	2	●	●
16	Rod packing	—					NBR		1	2	●	●
17	Snap ring	—					Spring steel		1	2	●	●
18	Washer	—					Carbon steel		1	2	●	●
19	Tie nut	—					Carbon steel		1	2	●	●
20	Rod front nut	—					Carbon steel		2	2	●	●
21	Port plug	—					Plastic		2	2	●	●

*1. Polyurethane *2. Carbon steel *3. Cylinder bore ø8~12 (Required quantity: 2 psc)

Order example

Component parts / Repair kits

Tube I.D.	Component parts	Repair kits
ø8	CP-MCFI-8	PS-MCFI-8
ø10	CP-MCFI-10	PS-MCFI-10
ø12	CP-MCFI-12	PS-MCFI-12
ø16	CP-MCFI-16	PS-MCFI-16
ø20	CP-MCFI-20	PS-MCFI-20
ø25	CP-MCFI-25	PS-MCFI-25

Non-pivot type (end-plain)

Tube I.D.	Component parts
ø8	CP-MCFI-8-N
ø10	CP-MCFI-10-N
ø12	CP-MCFI-12-N
ø16	CP-MCFI-16-N
ø20	CP-MCFI-20-N
ø25	CP-MCFI-25-N

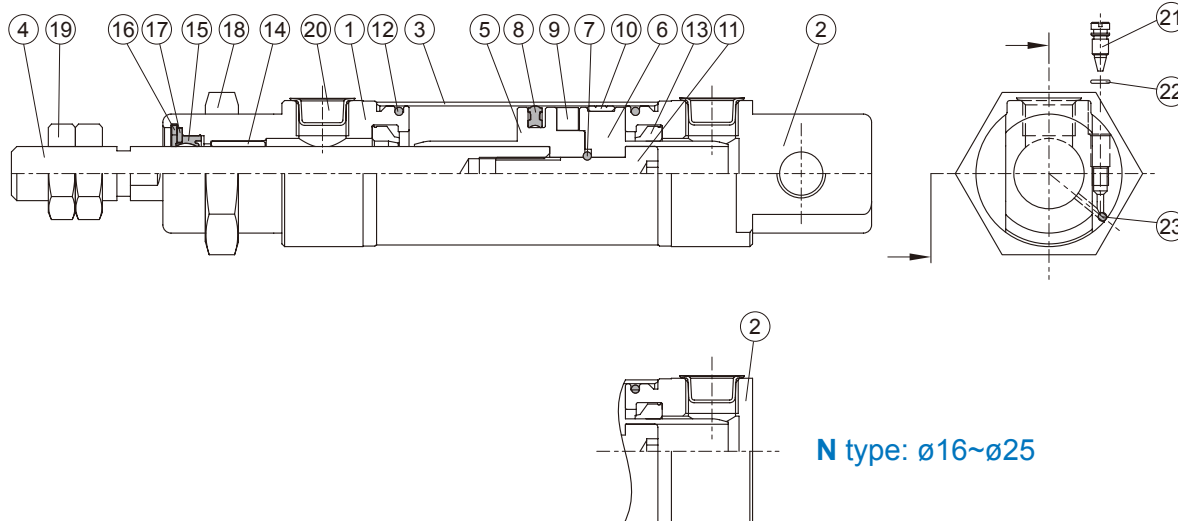

Material * Cylinder bore ø8~12 is not applicable.

No.	Tube I.D. Part name	16	20	25	Q'y		Component parts (inclusion)		Repair kits (inclusion)
					11 type	21 type	11 type	21 type	
1	Rod cover	Aluminum alloy			1	2	●	●	
2	Head cover	Aluminum alloy			1	—	●		
3	Tube	Stainless steel			1	1			
4	Piston rod	*1	Carbon steel	1	1				
5	Piston-R	Aluminum alloy			1	1	●	●	
6	Piston-H	Aluminum alloy			1	1	●	●	
7	Piston gasket	NBR			1	1	●	●	
8	Piston packing	NBR			1	1	●	●	
9	Magnet ring	Magnet material			1	1	●	●	
10	Wear ring	Teflon+Graphite			1	1	●	●	
11	Piston bolt	SCM			1	—	●		
12	Cover ring	NBR			2	2	●	●	
13	Cushion packing	NBR			2	2	●	●	
14	Rod bush	Bearing alloy			1	2	●	●	
15	Rod packing	NBR			1	2	●	●	●
16	Snap ring	Spring steel			1	2	●	●	
17	Washer	Carbon steel			1	2	●	●	
18	Tie nut	Carbon steel			1	2	●	●	
19	Rod front nut	Carbon steel			2	2	●	●	
20	Port plug	Plastic			2	2	●	●	
21	Needle valve	Stainless steel			2	2	●	●	
22	Needle valve packing	NBR			2	2	●	●	●
23	Steel ball	Stainless steel			2	2	●	●	

*1. Stainless steel

Order example

Component parts / Repair kits

Tube I.D.	Component parts	Repair kits
ø16	CP-MCFI-16A	PS-MCFI-16A
ø20	CP-MCFI-20A	PS-MCFI-20A
ø25	CP-MCFI-25A	PS-MCFI-25A

Non-pivot type (end-plain)

Tube I.D.	Component parts
ø16	CP-MCFI-16A-N
ø20	CP-MCFI-20A-N
ø25	CP-MCFI-25A-N

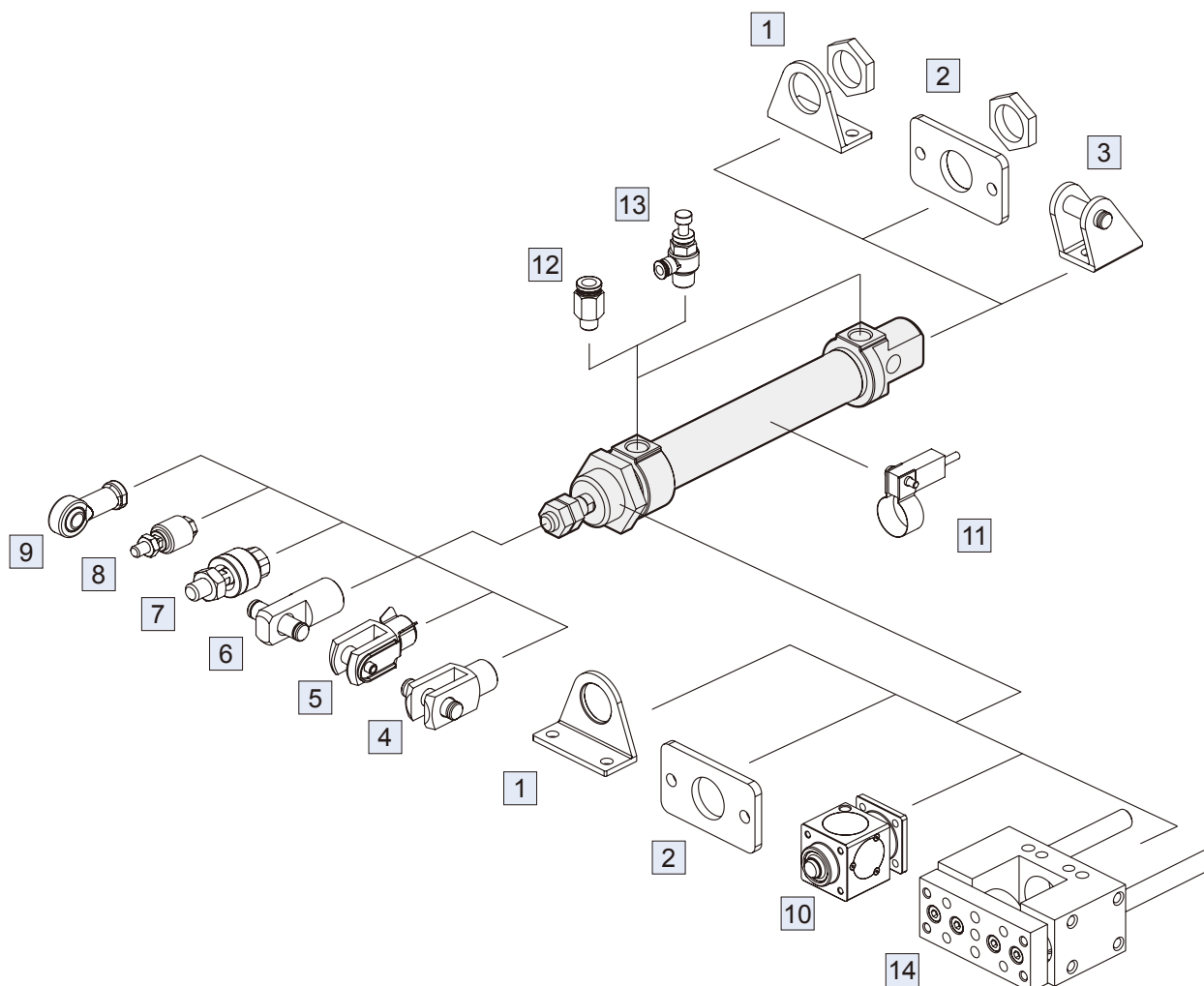

No.	Accessories	Page
1	Mounting accessories LB	3-45
2	Mounting accessories FA/FB	3-44, 46
3	Mounting accessories SDB+PIN	3-45, 13
4	Accessories Y+PIN	3-13
5	Accessories YS (Y+Floating pin)	3-13
6	Accessories I+PIN	3-13
7	Floating joint MFC	8-2
8	Floating joint MFCS	8-4

No.	Accessories	Page
9	Female rod ends PHS	8-5
10	Locking unit MCBMI	1-65
11	Sensor switch RCM+BM**	8-13
12	Fitting PC	8-5 (Vol.1)
13	Fitting JSC	8-18 (Vol.1)
14	Twin-guide cylinders MGTB/TK/TU	4-38

11

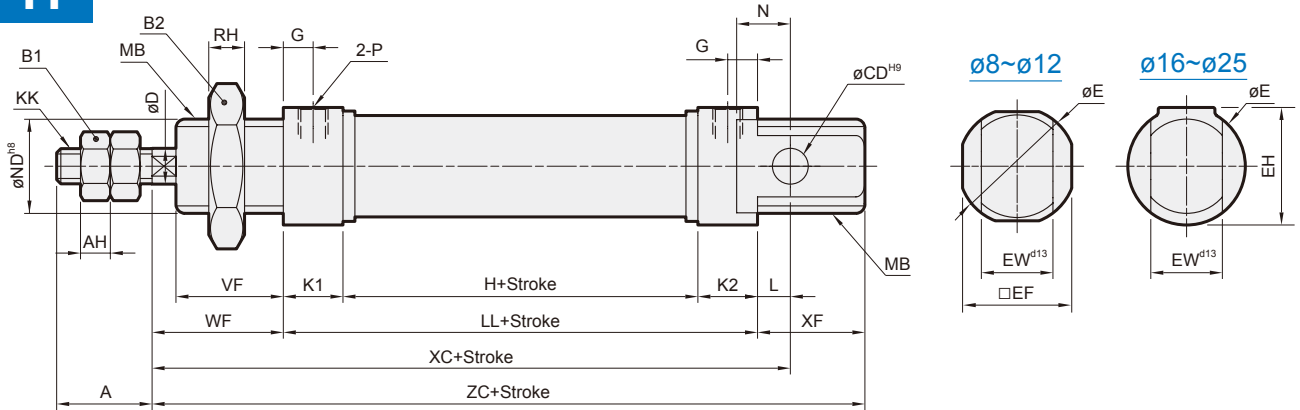

21

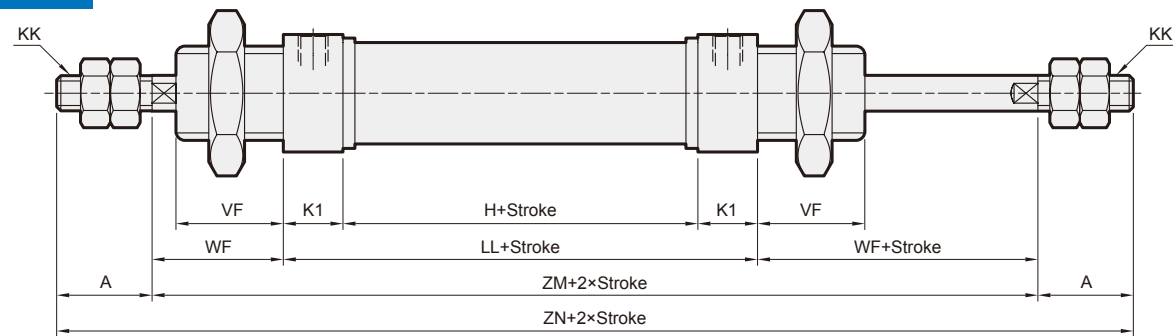

27

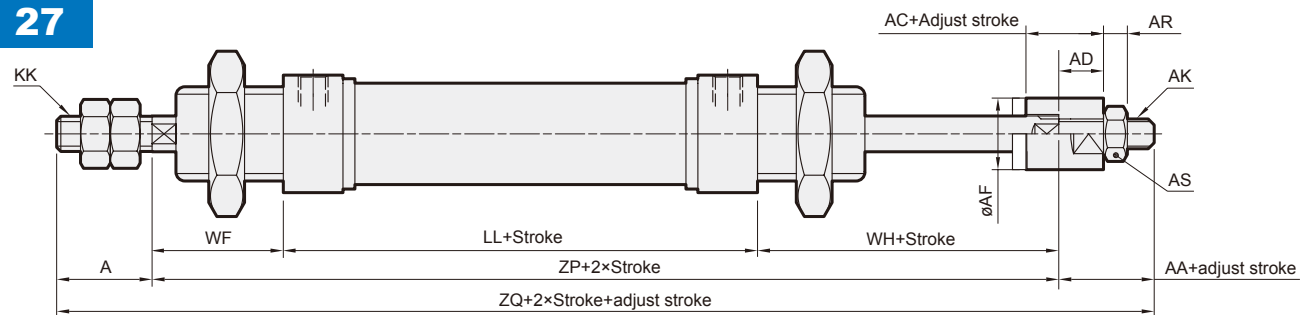

Code Tube I.D.	A	AA	AC	AD	AF	AH	AK	AR	AS	B1	B2	CD	D	E	EF	EH	EW	G	H	KK	K1	K2	L	LL
8	12	—	—	—	—	3.2	—	—	—	7	19	4	4	16.7	15	—	8	6	24	M4×0.7	11	11	2	46
10	12	—	—	—	—	3.2	—	—	—	7	19	4	4	16.7	15	—	8	6	24	M4×0.7	11	11	2	46
12	16	—	—	—	—	5	—	—	—	10	24	6	6	19.7	—	—	12	6	28	M6×1.0	11	11	3	50
16	16	16	13	7.5	12	5	M5×0.8	4	8	10	22	6	6	20	—	20	12	5	34.5	M6×1.0	10	10	5.5	54.5
20	20	19	15	9.5	16	5	M8×1.25	5	13	13	30	8	8	27	—	27	16	8	38	M8×1.25	15	15	3	68
25	22	19	15	9.5	16	5	M8×1.25	5	13	17	30	8	10	27	—	27	16	7.5	37	M10×1.25	15	15	9	67

Code Tube I.D.	MB	N	ND	P	RH	VF	WF	WH	XC	XF	ZC	ZM	ZN	ZP	ZQ
8	M12×1.25	6	12	M5×0.8	6	12	16	—	64	12	74	—	—	—	—
10	M12×1.25	6	12	M5×0.8	6	12	16	—	64	12	74	—	—	—	—
12	M16×1.5	9	16	M5×0.8	8	17	22	—	75	17	89	—	—	—	—
16	M16×1.5	9	16	M5×0.8	6	18	22	25.5	82	18	94.5	98.5	130.5	102	134
20	M22×1.5	12	22	G1/8	6	20	24	27	95	20	112	116	156	119	158
25	M22×1.5	12	22	G1/8	6	22	28	29.5	104	22	117	123	167	124.5	165.5

Sensor switch: RCM

Sensor switch band: BM**

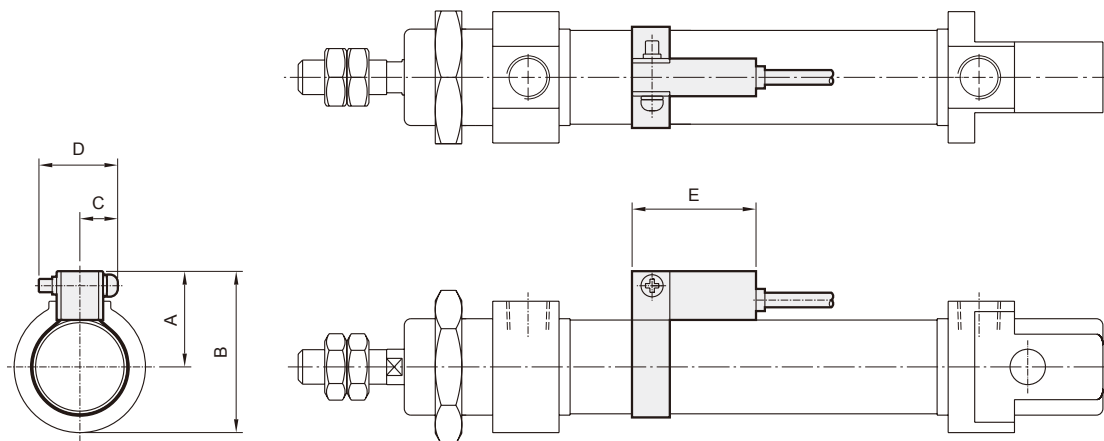

Code Tube I.D.	A	B	C	D	E
8	16	23.5	10	16	28
10	17	24.5	10	16	28
12	18	28	10	16	28
16	20	30	10	16	28
20	22	35.5	10	16	28
25	25	38.5	10	16	28

13

15

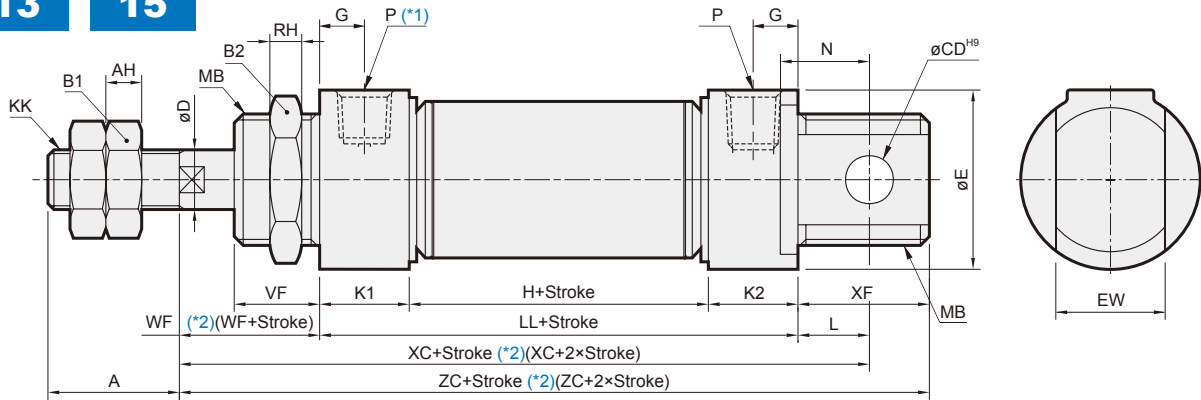

*1. 15 type $\phi 16$ without this air port.

*2. () Dimension for 13 type.

Code Tube I.D.	A	AH	B1	B2	CD	D	E	EW	G	KK	K1	K2	L	LA	MB	N	P	RH	VF	WF	XF	ZM	ZN	ZP	ZQ
16	16	5	10	22	6	6	20	12 ^{-0.05/-0.4}	5	M6×1.0	10	10	5.5	54.5	M16×1.5	9	M5×0.8	6	18	22	18	98.5	130.5	96	134
20	20	5	13	30	8	8	27	16 ^{-0.05/-0.4}	8	M8×1.25	15	15	3	68	M22×1.5	12	G1/8	6	20	24	20	116	156	119	158
25	22	6	17	30	8	10	27	16 ^{-0.05/-0.4}	7.5	M10×1.25	15	15	9	67	M22×1.5	12	G1/8	6	22	28	22	123	167	124.5	165.5

MCFM-13

Code Stroke Tube I.D.	H			LL			XC			ZC		
	1~50	51~100	101~150	1~50	51~100	101~150	1~50	51~100	101~150	1~50	51~100	101~150
16	53.5	79.5	105.5	73.5	99.5	125.5	101	127	153	113.5	139.5	165.5
20	63	88	113	93	118	143	120	145	170	137	162	187
25	60.5	85.5	110.5	90.5	115.5	140.5	127.5	152.5	177.5	140.5	165.5	190.5

MCFM-15

Code Stroke Tube I.D.	H			LL			XC			ZC		
	1~50	51~100	101~150	1~50	51~100	101~150	1~50	51~100	101~150	1~50	51~100	101~150
16	34.5	50	65.5	54.5	70	85.5	82	97.5	113	94.5	110	125.5
20	38	88	113	68	118	143	95	145	170	112	162	187
25	37	85.5	110.5	67	115.5	140.5	104	152.5	177.5	117	165.5	190.5

Mounting accessories – Double acting

FA/FB

Code Tube I.D.	A	FB	FE	FF	FP	FT	KK	W	ZC	ZF
8	12	4.5	22	40	30	3.2	M4×0.7	12.8	74	65.2
10	12	4.5	22	40	30	3.2	M4×0.7	12.8	74	65.2
12	16	5.5	26	52	40	3.2	M6×1.0	18.8	89	75.2
16	16	5.5	26	52	40	3.2	M6×1.0	18.8	94.5	79.7
20	20	6.6	38	64	50	4.5	M8×1.25	19.5	112	96.5
25	22	6.6	38	64	50	4.5	M10×1.25	23.5	117	99.5

$\phi 12, \phi 16$

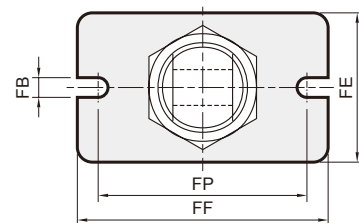

$\phi 8, \phi 10, \phi 20, \phi 25$

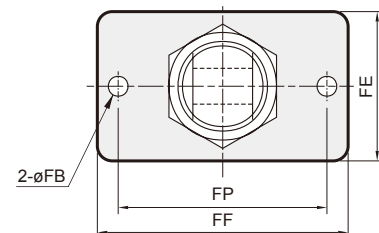
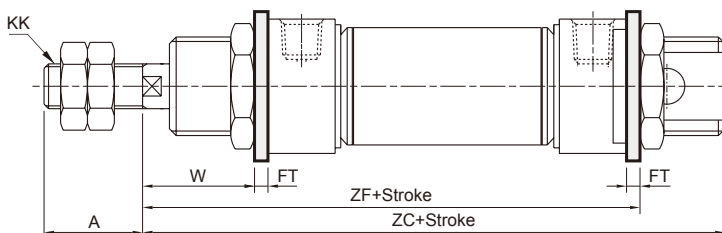

SDB

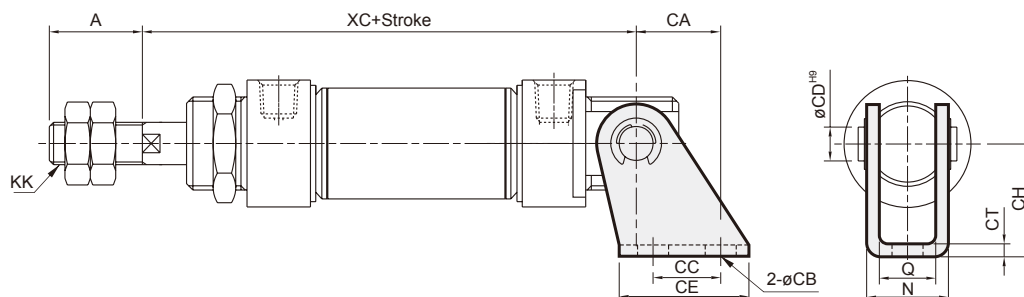

Code Tube I.D.	A	CA	CB	CC	CD	CE	CH	CT	KK	N	Q	XC
8	12	11	4.5	12.5	4	20	24	2.5	M4×0.7	13.1	8.1	64
10	12	11	4.5	12.5	4	20	24	2.5	M4×0.7	13.1	8.1	64
12	16	13	5.5	15	6	25	27	3.2	M6×1.0	18.5	12.1	75
16	16	13	5.5	15	6	25	27	3.2	M6×1.0	18.5	12.1	82
20	20	16	6.6	20	8	32	30	3.2	M8×1.25	22.5	16.1	95
25	22	16	6.6	20	8	32	30	3.2	M10×1.25	22.5	16.1	104

LB

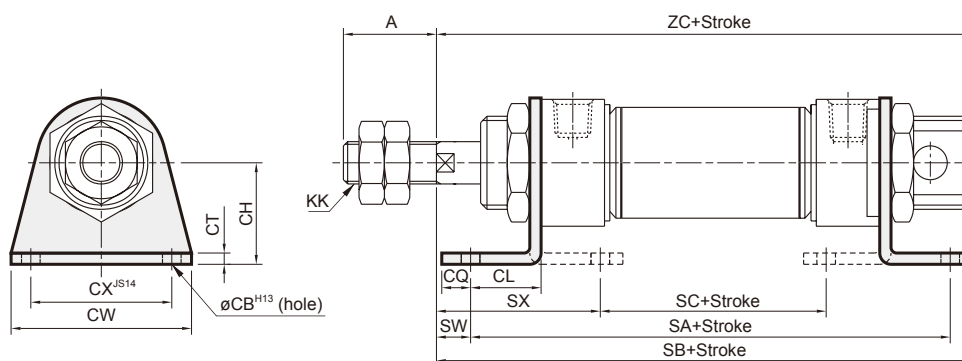

Code Tube I.D.	A	CB	CH	CL	CQ	CT	CW	CX	KK	SA	SB	SC	SW	SX	ZC
8	12	4.5	16	11	5	3.2	35	25	M4×0.7	68	78	30.4	5	23.8	74
10	12	4.5	16	11	5	3.2	35	25	M4×0.7	68	78	30.4	5	23.8	74
12	16	5.5	20	14	6	4	42	32	M6×1.0	78	92	30	8	32	89
16	16	5.5	20	14	6	4	42	32	M6×1.0	82.5	96.5	34.5	8	32	94.5
20	20	6.6	25	15	8	3.2	54	40	M8×1.25	98	115	44.4	9	35.8	112
25	22	6.6	25	15	8	3.2	54	40	M10×1.25	97	118	43.4	13	39.8	117

N

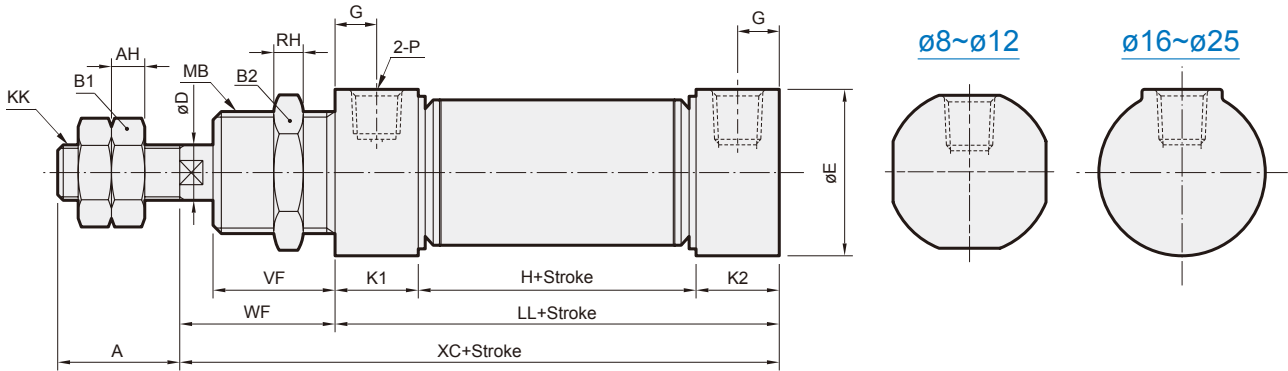

Code Tube I.D.	A	AH	B1	B2	D	E	G	H	KK	K1	K2	LL	MB	P	RH	VF	WF	XC
8	12	3.2	7	19	4	16.7	6	24	M4×0.7	11	11	46	M12×1.25	M5×0.8	6	12	16	62
10	12	3.2	7	19	4	16.7	6	24	M4×0.7	11	11	46	M12×1.25	M5×0.8	6	12	16	62
12	16	5	10	24	6	19.7	6	28	M6×1.0	11	11	50	M16×1.5	M5×0.8	8	17	22	72
16	16	5	10	22	6	20	5	34.5	M6×1.0	10	10	54.5	M16×1.5	M5×0.8	6	18	22	76.5
20	20	5	13	30	8	27	8	38	M8×1.25	15	15	68	M22×1.5	G1/8	6	20	24	92
25	22	5	17	30	10	27	7.5	37	M10×1.25	15	15	67	M22×1.5	G1/8	6	22	28	95

FA

Code Tube I.D.	A	FB	FE	FF	FP	FT	W	XC
8	12	4.5	22	40	30	3.2	12.8	62
10	12	4.5	22	40	30	3.2	12.8	62
12	16	5.5	26	52	40	3.2	18.8	72
16	16	5.5	26	52	40	3.2	18.8	76.5
20	20	6.6	38	64	50	4.5	19.5	92
25	22	6.6	38	64	50	4.5	23.5	96

$\phi 12, \phi 16$

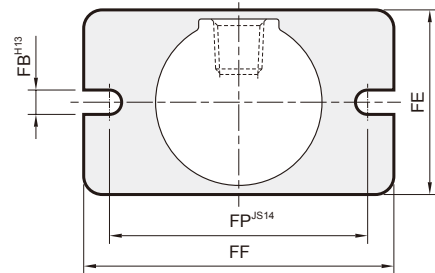

$\phi 8, \phi 10, \phi 20, \phi 25$

