

### Table for standard stroke

	Tube I.D.	Stroke (mm)
Single acting	ø16	15,25,50,75,100
	ø20, 25, 32	15,25,50,75,100,125,150
Double acting	ø16	15,25,50,75,100,125,150,200,250,300,350,400,450,500
	ø20, 25, 32,40	15,25,50,75,100,125,150,200,250,300,350,400,450,500

- Available with double action type cylinder with stroke more than 500 mm. Sub-piston increases the total length of cylinder by 10 mm and provides further stability.
- Please consult us if stroke out of specification.

### Order example

MCMA – 11 – 32 – 100 – A – N – □

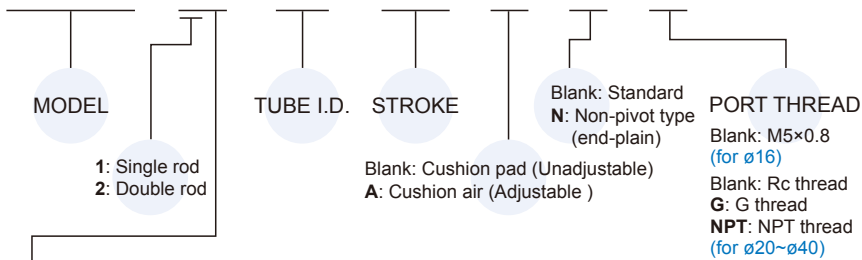

#### STYLE

Code	Symbol	Description
1 1		Double acting / Male thread
1 3		Single acting / Normally extended male thread
1 5		Single acting / Normally returned male thread
2 1		Double rod / Male thread
2 3		Single acting / Double rod male thread
2 7		Double rod / Adjustable male thread Please mark "adjustable distance(mm)" at order list

\* Order example for special specification, refer to page 0-7.

### Features

#### ■ Non lubrication

- Special housing and bushing enables self lubrication of piston rod.

#### ■ High quality long service life

- Hard anodised stainless steel cylinder tubes offer a high resistance to corrosion and low internal friction.
- Cylinder mountings, available with a comprehensive range of accessories for rigid or flexible mounting.
- Operation, with the exception of MCMA-11, single and doubling type available MCMA-13 / 15.

#### ■ Magnetic as standard

### Specification

Model	MCMA					
Tube I.D.	16	20	25	32	40	
Port size	M5×0.8	Rc1/8				
Medium	Air					
Max. operating perssure	0.7 MPa					
Min. operating perssure	Double: 0.06 MPa ; Single: 0.15 MPa					
Proof pressure	1 MPa					
Available speed range	50~500 mm/sec					
Ambient temperature	-5~+60°C (No freezing)					
Lubricator	Not required					
Max. allowable kinetic energy (J)	Cushion pad	0.16	0.27	0.4	0.65	1.2
	Cushion air	0.32	0.54	0.78	1.27	2.35
Sensor switch (*)	RCM					
Sensor switch (band)	BM16	BM20	BM25	BM32	BM40	

\* RCM specification, please refer to page 8-13.

### Mounting accessories

FA – MCMA – 32

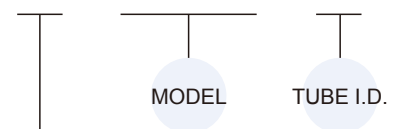

#### MOUNTING TYPE

	LB
	FA
	FB
	SDB
	Y
	I
	YS (Y+Flaing+PIN)

ø16, ø20

**N type: ø16~ø40**

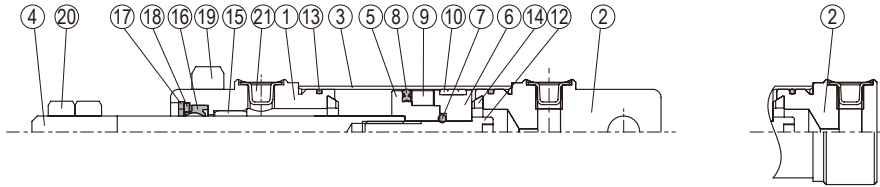

ø25

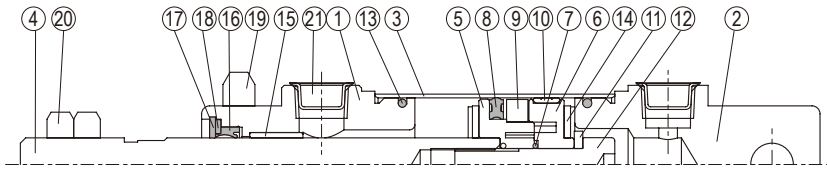

ø32, ø40

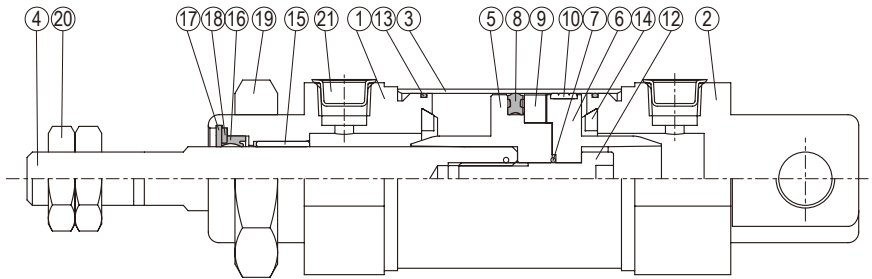

### Material

No.	Tube I.D. Part name	16	20	25	32	40	Q'y		Component parts (inclusion)		Repair kits (inclusion)
							11 type	21 type	11 type	21 type	
1	Rod cover	Aluminum alloy					1	2	●	●	
2	Head cover	Aluminum alloy					1	—	●		
3	Tube	Stainless steel					1	1			
4	Piston rod	*1	Carbon steel					1	1		
5	Piston-R	Aluminum alloy		*2	Aluminum alloy		1	1	●	●	
6	Piston-H	Aluminum alloy		*2	Aluminum alloy		1	1	●	●	
7	Piston gasket	NBR					1	1	●	●	
8	Piston packing	NBR					1	1	●	●	
9	Magnet ring	Magnet material					1	1	●	●	
10	Wear ring	Teflon+Graphite					1	1	●	●	
11	Washer	—		*3	—		1	—	●		
12	Piston bolt	SCM					1	—	●		
13	Cover ring	NBR					2	2	●	●	
14	Cushion gasket	NBR					2	2	●	●	
15	Rod bush	Bearing alloy					1	2	●	●	
16	Rod packing	NBR					1	2	●	●	●
17	Snap ring	Spring steel					1	2	●	●	
18	Washer	Carbon steel					1	2	●	●	
19	Tie nut	Carbon steel					1	2	●	●	
20	Rod front nut	Carbon steel					2	2	●	●	
21	Port plug	Plastic					2	2	●	●	

\*1. Stainless steel \*2. Polyurethane \*3. Carbon steel

### Order example

#### Component parts / Repair kits

Tube I.D.	Component parts	Repair kits
ø16	CP-MCMA-16	PS-MCMA-16
ø20	CP-MCMA-20	PS-MCMA-20
ø25	CP-MCMA-25	PS-MCMA-25
ø32	CP-MCMA-32	PS-MCMA-32
ø40	CP-MCMA-40	PS-MCMA-40

#### Non-pivot type (end-plain)

Tube I.D.	Component parts
ø16	CP-MCMA-16-N
ø20	CP-MCMA-20-N
ø25	CP-MCMA-25-N
ø32	CP-MCMA-32-N
ø40	CP-MCMA-40-N

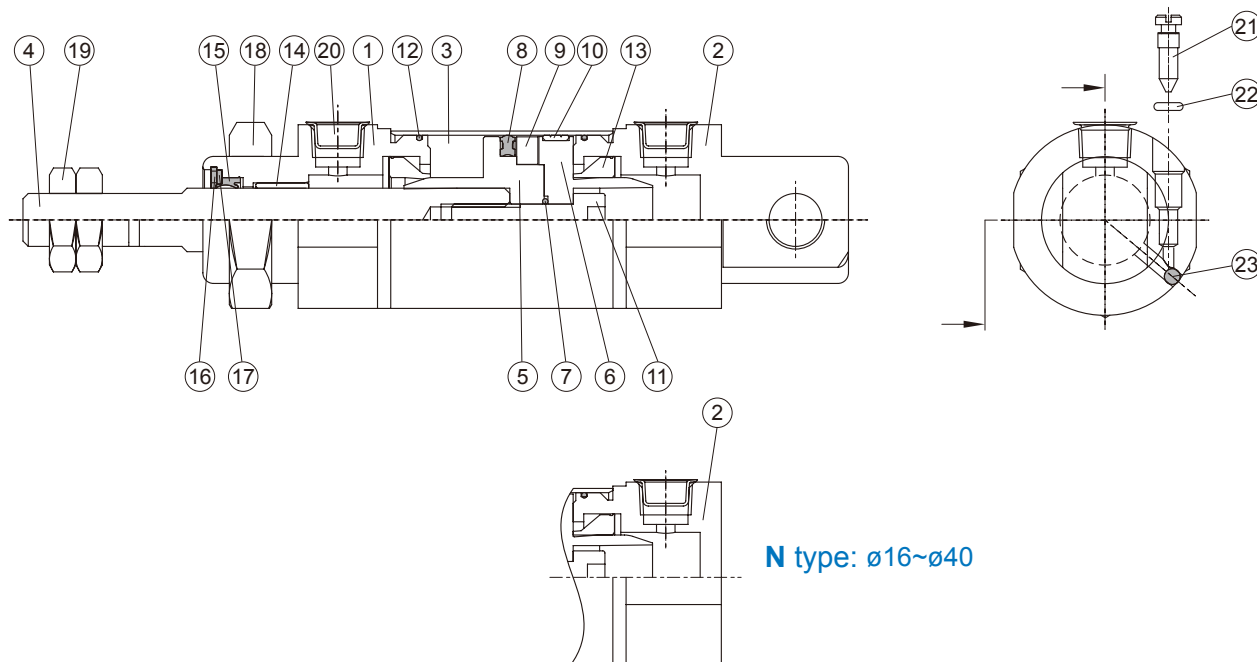

### Material

No.	Tube I.D. Part name	16	20	25	32	40	Q'y		Component parts (inclusion)		Repair kits (inclusion)	
							11 type	21 type	11 type	21 type		
1	Rod cover	Aluminum alloy					1	2	●	●		
2	Head cover	Aluminum alloy					1	—	●			
3	Tube	Stainless steel					1	1				
4	Piston rod	*1	Carbon steel					1	1			
5	Piston-R		*2		*3	*2	1	1	●	●		
6	Piston-H		*2		*3	*2	1	1	●	●		
7	Piston gasket	NBR					1	1	●	●		
8	Piston packing	NBR					1	1	●	●		
9	Magnet ring	Magnet material					1	1	●	●		
10	Wear ring	Teflon+Graphite					1	1	●	●		
11	Piston bolt	SCM					1	—	●			
12	Cover ring	NBR					2	—	●	●		
13	Cushion packing	NBR					2	2	●	●		
14	Rod bush	Bearing alloy					1	2	●	●		
15	Rod packing	NBR					1	2	●	●	●	
16	Snap ring	Spring steel					1	2	●	●		
17	Washer	Carbon steel					1	2	●	●		
18	Tie nut	Carbon steel					1	2	●	●		
19	Rod front nut	Carbon steel					2	2	●	●		
20	Port plug	Plastic					2	2	●	●		
21	Needle valve	*1	Carbon steel					2	2	●	●	
22	Needle valve packing	NBR					2	2	●	●	●	
23	Steel ball	Stainless steel					2	2	●	●		

\*1. Stainless steel \*2. Aluminum alloy \*3. Polyurethane

### Order example

#### Component parts / Repair kits

Tube I.D.	Component parts	Repair kits
ø16	CP-MCMA-16A	PS-MCMA-16A
ø20	CP-MCMA-20A	PS-MCMA-20A
ø25	CP-MCMA-25A	PS-MCMA-25A
ø32	CP-MCMA-32A	PS-MCMA-32A
ø40	CP-MCMA-40A	PS-MCMA-40A

#### Non-pivot type (end-plain)

Tube I.D.	Component parts
ø16	CP-MCMA-16A-N
ø20	CP-MCMA-20A-N
ø25	CP-MCMA-25A-N
ø32	CP-MCMA-32A-N
ø40	CP-MCMA-40A-N

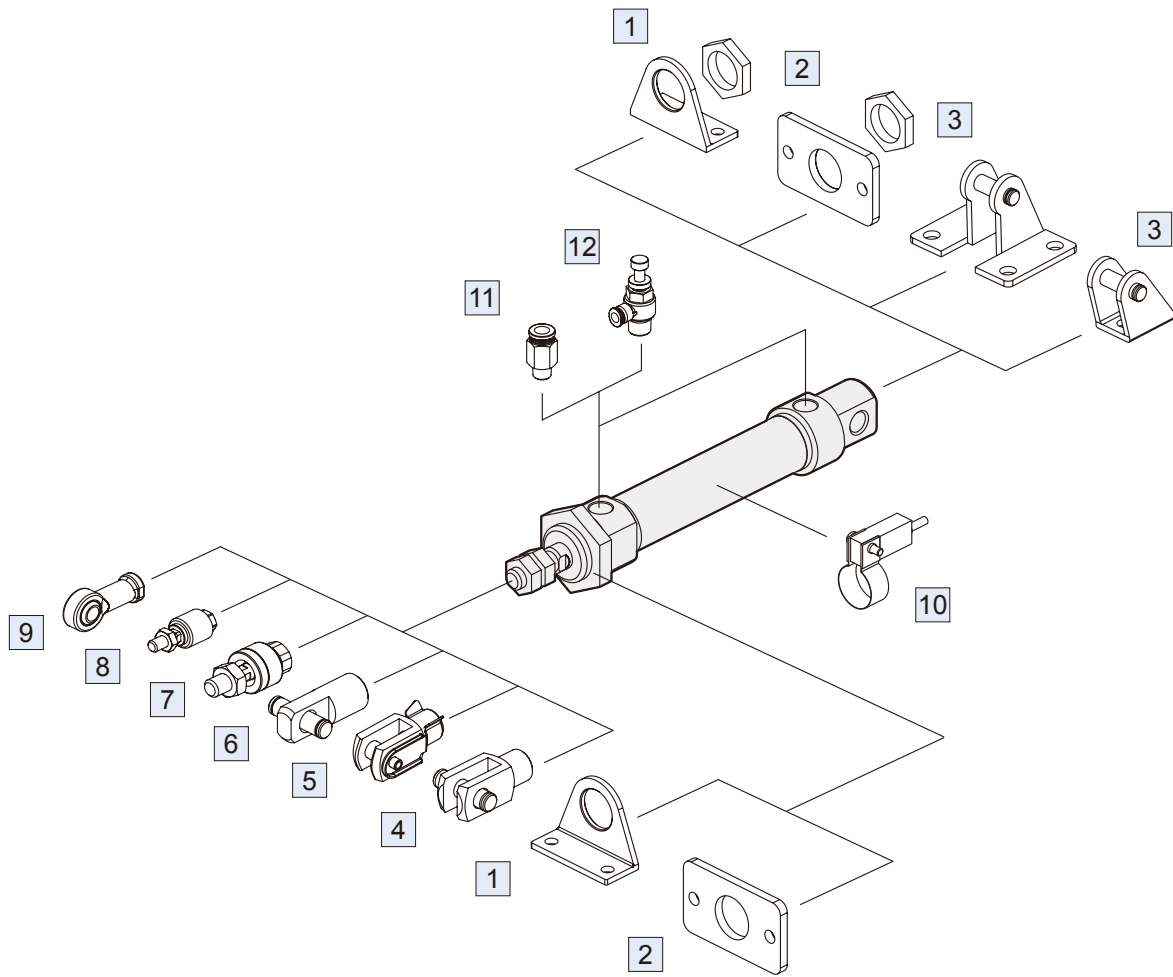

No.	Accessories	Page
1	Mounting accessories LB	3-7, 11
2	Mounting accessories FA/FB	3-8, 12
3	Mounting accessories SDB+PIN	3-8, 12, 13
4	Accessories Y+PIN	3-13
5	Accessories YS (Y+Floating pin)	3-13
6	Accessories I+PIN	3-13

No.	Accessories	Page
7	Floating joint MFC	8-2
8	Floating joint MFCS	8-4
9	Female rod ends PHS	8-5
10	Sensor switch RCM+BM**	8-13
11	Fitting PC (PISCO)	8-5 (Vol.1)
12	Speed controller JSC (PISCO)	8-18 (Vol.1)

## MINIATURE CYLINDER

Mindman

11

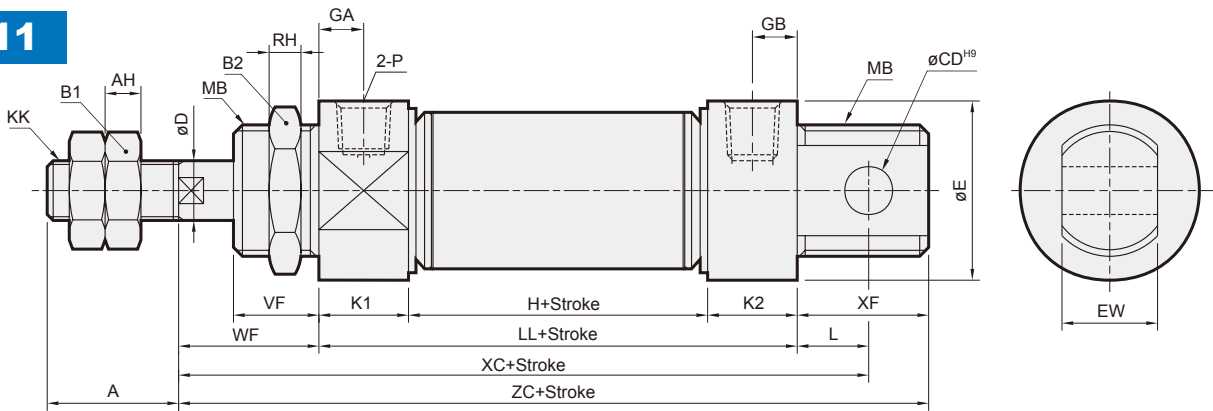

21

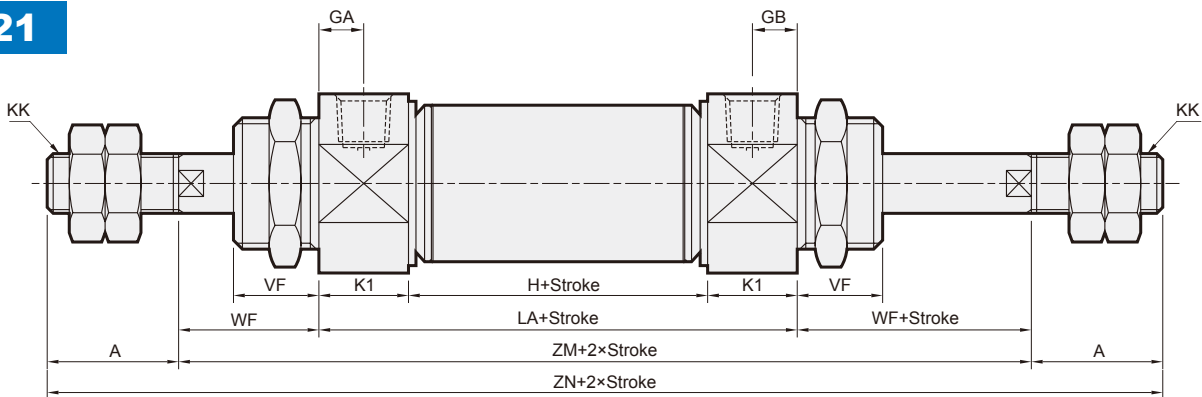

27

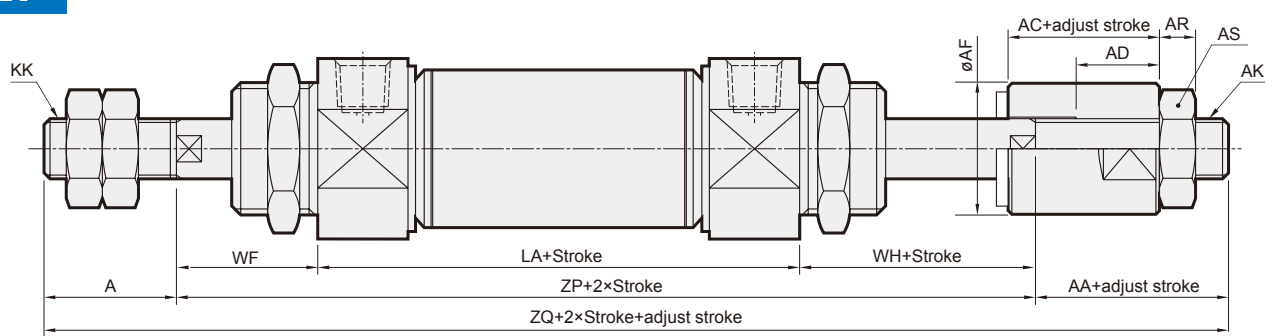

Code Tube I.D.	A	AA	AC	AD	AF	AH	AR	AS	AK	B1	B2	CD	D	E	EW	GA	GB	H	KK
16	16	16	13	7.5	12	5	4	8	M5×0.8	10	22	6	6	19.7	12 <sup>-0.05</sup> <sub>-0.4</sub>	5	5	34	M6×1.0
20	20	19	15	9.5	16	5	5	13	M8×1.25	13	30	8	8	26.7	16 <sup>-0.05</sup> <sub>-0.4</sub>	7.5	7.5	40	M8×1.25
25	22	19	15	9.5	16	5	5	13	M8×1.25	17	30	8	10	29.7	16 <sup>-0.05</sup> <sub>-0.4</sub>	7.5	7.5	40	M10×1.25
32	22	18	12	7	20	5	6	17	M10×1.25	17	32	10	12	36	16 <sup>-0.05</sup> <sub>-0.4</sub>	7.5	10.5	37	M10×1.25
40	30	18	12	7	30	7	7	19	M12×1.25	19	41	12	14	45	20 <sup>-0.05</sup> <sub>-0.4</sub>	7.5	10.5	42	M12×1.25

Code Tube I.D.	K1	K2	L	LA	LL	MB	P	RH	VF	WF	WH	XC	XF	ZC	ZM	ZN	ZP	ZQ
16	10	10	9	54	54	M16×1.5	M5×0.8	6	12	22	19.5	85	16	92	98	130	95.5	127.5
20	15	15	12	70	70	M22×1.5	Rc1/8	6	12	18	19.5	100	21	109	106	146	107.5	146.5
25	15	15	12	70	70	M22×1.5	Rc1/8	6	15	27	22.5	109	21	118	124	168	119.5	160.5
32	15	18	14	67	70	M24×2.0	Rc1/8	8	18	30	24	114	24	124	127	171	121	161
40	15	18	16	72	75	M30×2.0	Rc1/8	8	17	27	24	118	28	130	126	186	123	171

## MINIATURE CYLINDER

### N

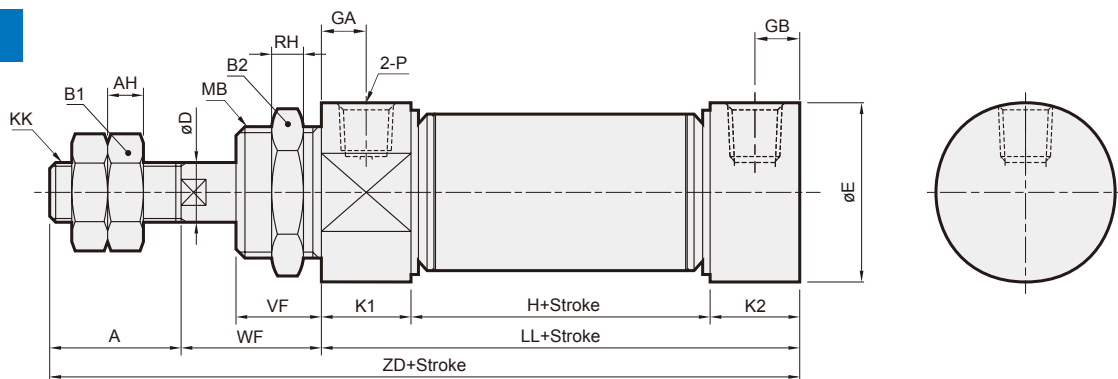

Code Tube I.D.	A	AH	B1	B2	D	E	GA	GB	H	KK	K1	K2	LL	MB	P	RH	VF	WF	ZD
16	16	5	10	22	6	19.7	5	5	34	M6×1.0	10	10	54	M16×1.5	M5×0.8	6	12	22	92
20	20	5	13	30	8	26.7	7.5	7.5	40	M8×1.25	15	15	70	M22×1.5	Rc1/8	6	12	18	108
25	22	6	17	30	10	29.7	7.5	7.5	40	M10×1.25	15	15	70	M22×1.5	Rc1/8	6	15	27	119
32	22	6	17	32	12	36	7.5	10.5	37	M10×1.25	15	18	70	M24×2.0	Rc1/8	8	18	30	122
40	30	7	19	41	14	45	7.5	10.5	42	M12×1.25	15	18	75	M30×2.0	Rc1/8	8	17	27	132

### Mounting accessories

### LB

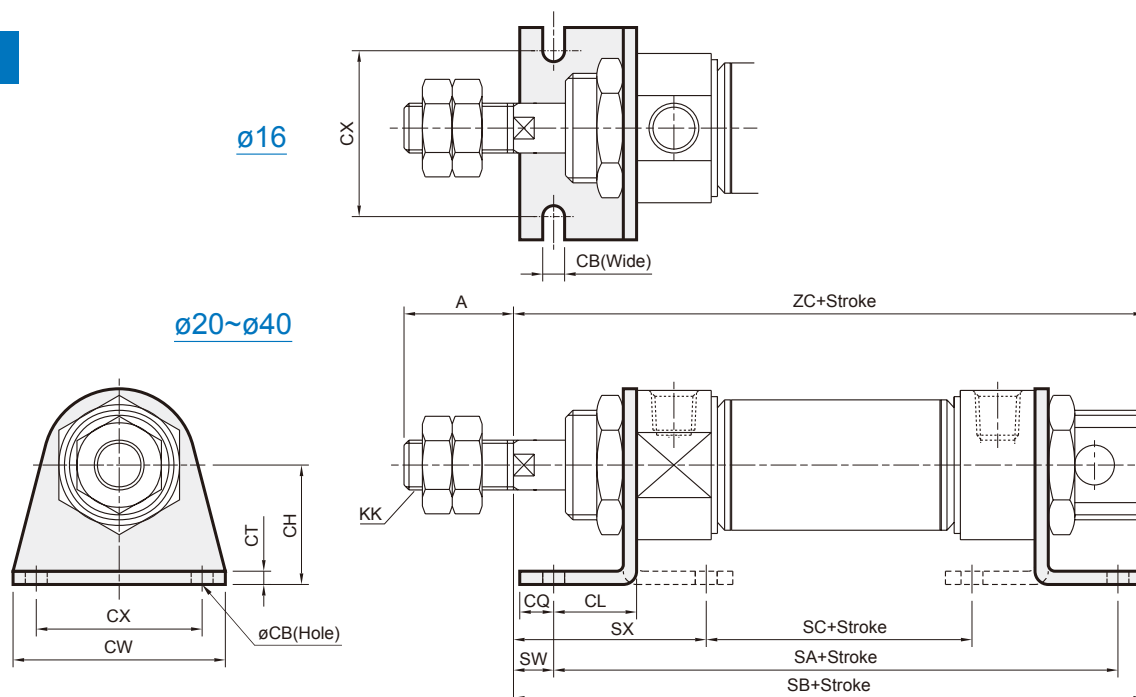

Code Tube I.D.	A	CB	CH	CL	CQ	CT	CW	CX	KK	SA	SB	SC	SW	SX	ZC
16	16	5.5	20	13	6	3.2	44	32	M6×1.0	80	95	34.4	9	31.8	92
20	20	6.6	25	15	8	3.2	54	40	M8×1.25	100	111	46.4	3	29.8	109
25	22	6.6	25	15	8	3.2	54	40	M10×1.25	100	120	46.4	12	38.8	118
32	22	6.6	32	25	8	4	59	45	M10×1.25	120	133	28	5	51	124
40	30	6.6	36	25	8	4	64	50	M12×1.25	125	135	33	2	48	130

**FA/FB**

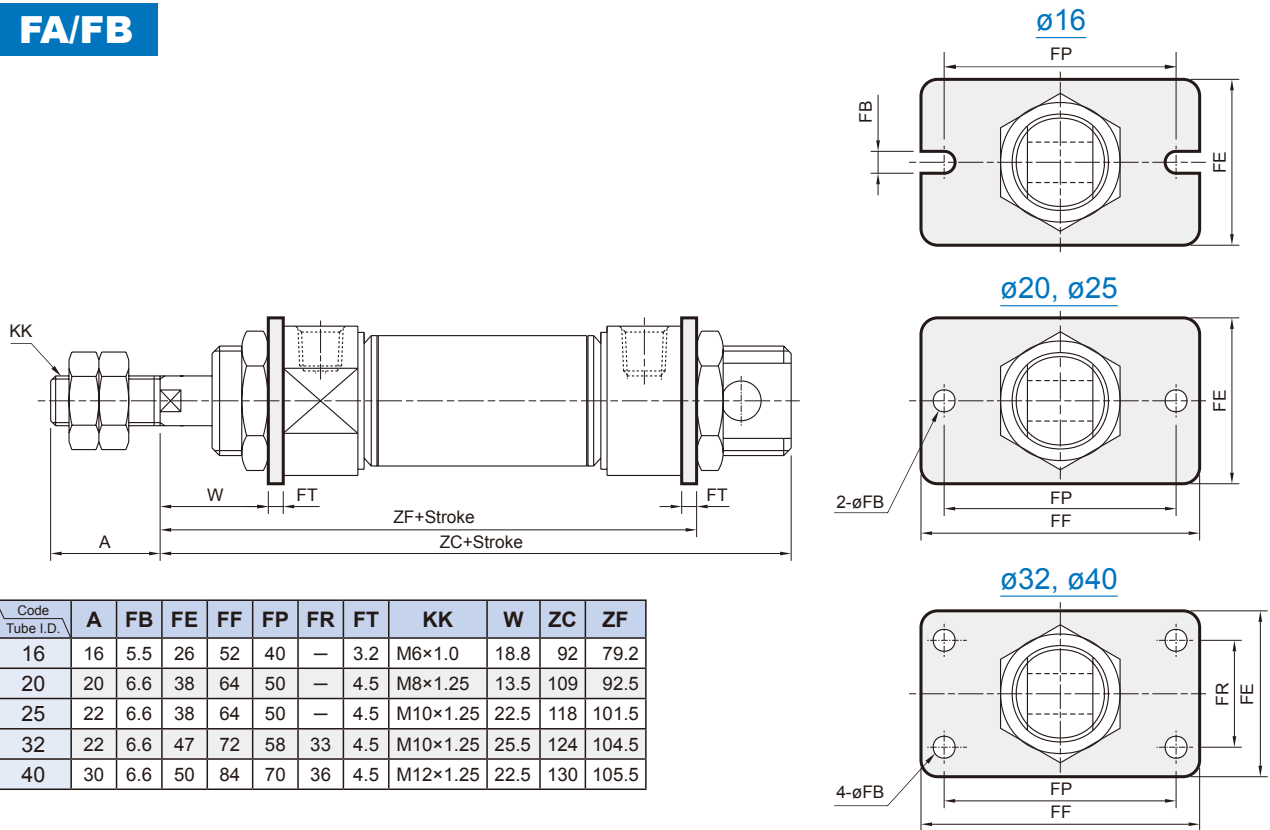

Code Tube I.D.	A	FB	FE	FF	FP	FR	FT	KK	W	ZC	ZF
16	16	5.5	26	52	40	—	3.2	M6×1.0	18.8	92	79.2
20	20	6.6	38	64	50	—	4.5	M8×1.25	13.5	109	92.5
25	22	6.6	38	64	50	—	4.5	M10×1.25	22.5	118	101.5
32	22	6.6	47	72	58	33	4.5	M10×1.25	25.5	124	104.5
40	30	6.6	50	84	70	36	4.5	M12×1.25	22.5	130	105.5

**SDB**

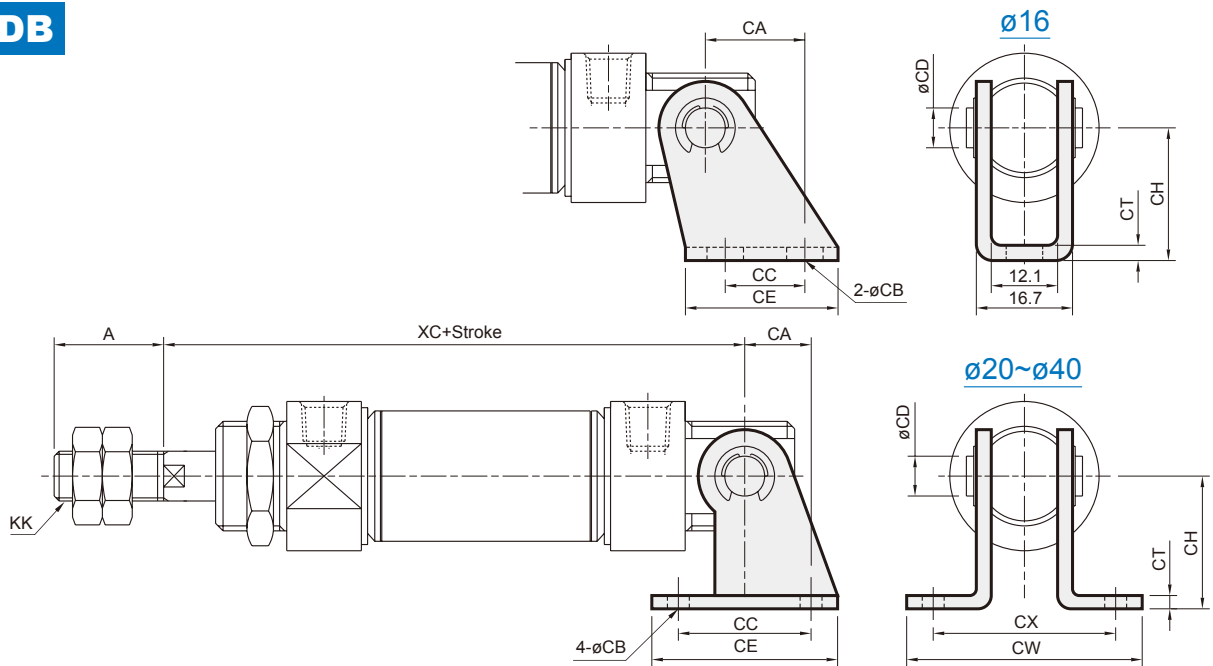

Code Tube I.D.	A	CA	CB	CC	CD	CE	CH	CT	CW	CX	KK	XC
16	16	15	5.5	12	6	23	20	2.3	—	—	M6×1.0	85
20	20	16	6.6	32	8	48	32	3.2	67	51	M8×1.25	100
25	22	16	6.6	32	8	48	32	3.2	67	51	M10×1.25	109
32	22	18	6.6	36	10	52	36	4	67	51	M10×1.25	114
40	30	20	6.6	40	12	56	40	4	69	53	M12×1.25	118

**MINIATURE CYLINDER**

Sensor switch: RCM  
Sensor switch band: BM\*\*

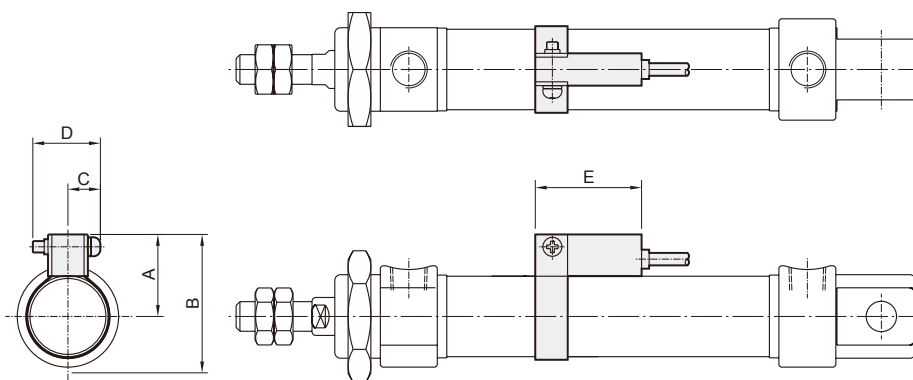

Code Tube I.D.	A	B	C	D	E
16	20	30	10	16	28
20	22	36	10	16	28
25	25	40	10	16	28
32	28	46	10	16	28
40	32	55	10	16	28



MINIATURE CYLINDER

15

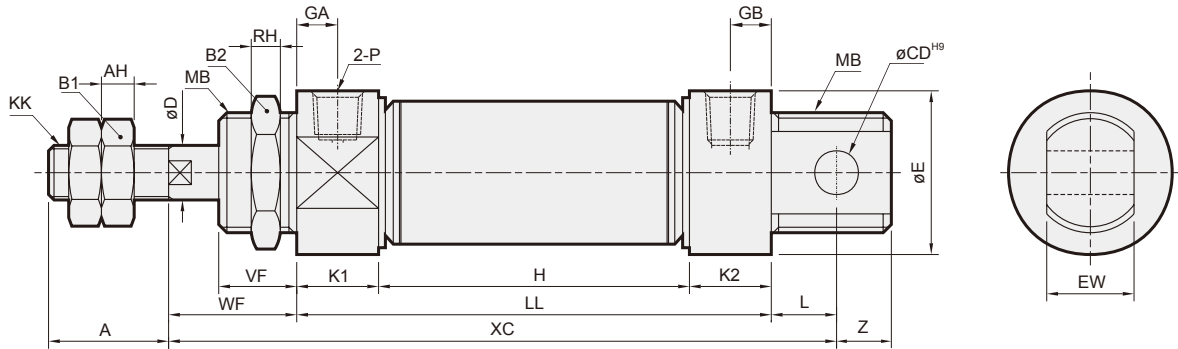

Code Tube I.D.	A	AH	B1	B2	CD	D	E	EW	GA	GB	KK	K1	K2	L	MB	P	RH	VF	WF	Z
16	16	5	10	22	6	6	19.7	12 <sup>-0.05/-0.4</sup>	5	5	M6×1.0	10	10	9	M16×1.5	M5×0.8	6	12	22	7
20	20	5	13	30	8	8	26.7	16 <sup>-0.05/-0.4</sup>	7.5	7.5	M8×1.25	15	15	12	M22×1.5	Rc1/8	6	12	18	9
25	22	6	17	30	8	10	29.7	16 <sup>-0.05/-0.4</sup>	7.5	7.5	M10×1.25	15	15	12	M22×1.5	Rc1/8	6	15	27	9
32	22	6	17	32	10	12	36	16 <sup>-0.05/-0.4</sup>	7.5	10.5	M10×1.25	15	18	14	M24×2.0	Rc1/8	8	18	30	10

Code Stroke Tube I.D.	H							LL							XC						
	15	25	50	75	100	125	150	15	25	50	75	100	125	150	15	25	50	75	100	125	150
16	64	74	114	154	194	—	—	84	94	134	174	214	—	—	115	125	165	205	245	—	—
20	80	90	140	190	240	290	340	110	120	170	220	270	320	370	140	150	200	250	300	350	400
25	80	90	140	190	240	290	340	110	120	170	220	270	320	370	149	159	209	259	309	359	409
32	77	87	137	187	237	287	337	110	120	170	220	270	320	370	154	164	214	264	314	364	414

23

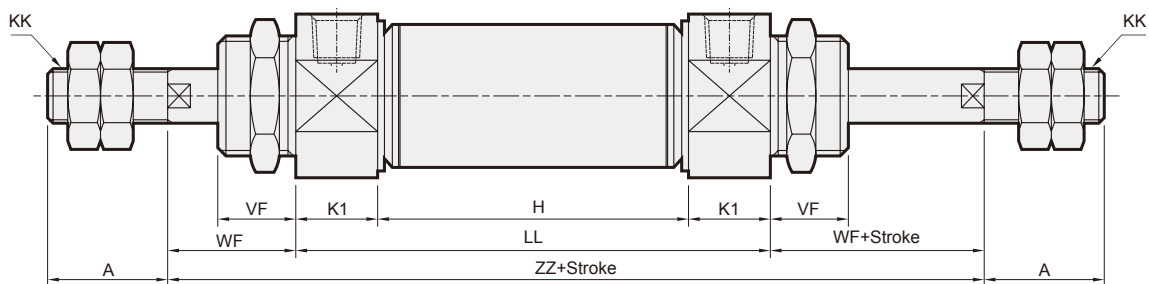

Code Stroke Tube I.D.	H							LL							ZZ						
	15	25	50	75	100	125	150	15	25	50	75	100	125	150	15	25	50	75	100	125	150
16	64	74	114	154	194	—	—	84	94	134	174	214	—	—	125	135	175	215	255	—	—
20	80	90	140	190	240	290	340	110	120	170	220	270	320	370	146	156	206	256	306	356	406
25	80	90	140	190	240	290	340	110	120	170	220	270	320	370	164	174	224	274	324	374	424
32	77	87	137	187	237	287	337	107	117	167	217	267	317	367	167	177	227	277	327	377	427

MINIATURE CYLINDER

LB

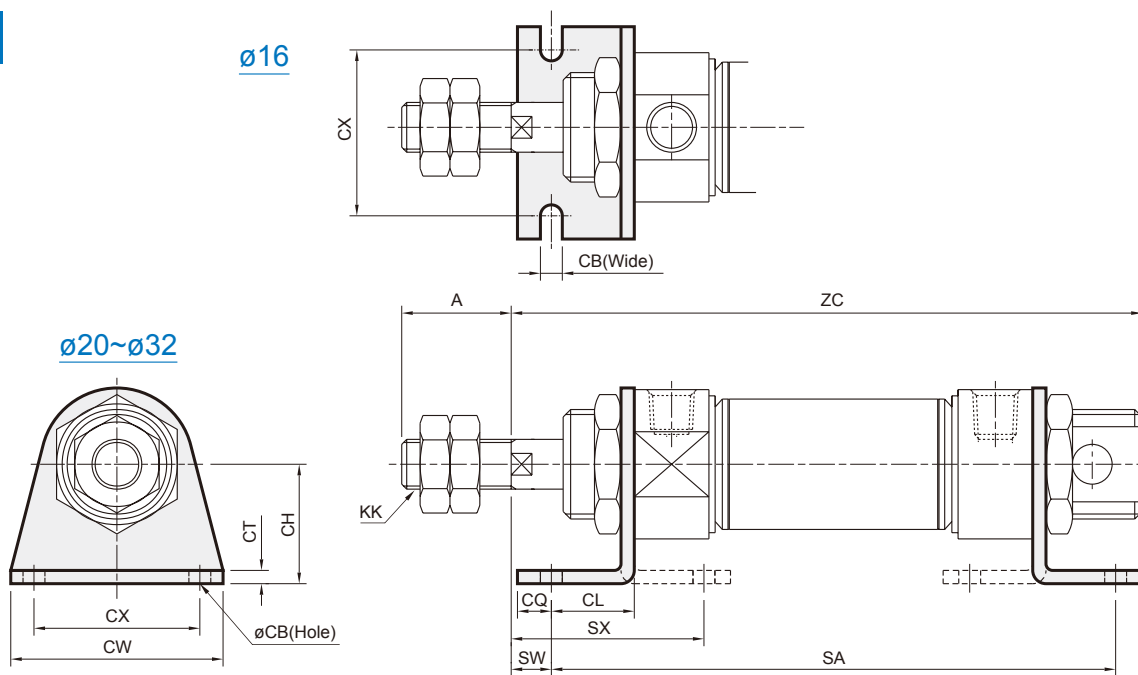

Code Tube I.D.	A	CB	CH	CL	CQ	CT	CW	CX	KK	SW	SX
16	16	5.5	20	13	6	3.2	44	32	M6×1.0	9	31.8
20	20	6.6	25	15	8	3.2	54	40	M8×1.25	3	29.8
25	22	6.6	25	15	8	3.2	54	40	M10×1.25	12	38.8
32	22	6.6	32	25	8	4	59	45	M10×1.25	5	51

Code Stroke Tube I.D.	SA							ZC						
	15	25	50	75	100	125	150	15	25	50	75	100	125	150
16	110	120	160	200	240	—	—	121	131	171	211	251	—	—
20	140	150	200	250	300	350	400	146	156	206	256	306	356	406
25	140	150	200	250	300	350	400	155	165	215	265	315	365	415
32	160	170	220	270	320	370	420	162	172	222	272	322	372	422

MINIATURE CYLINDER

FA/FB

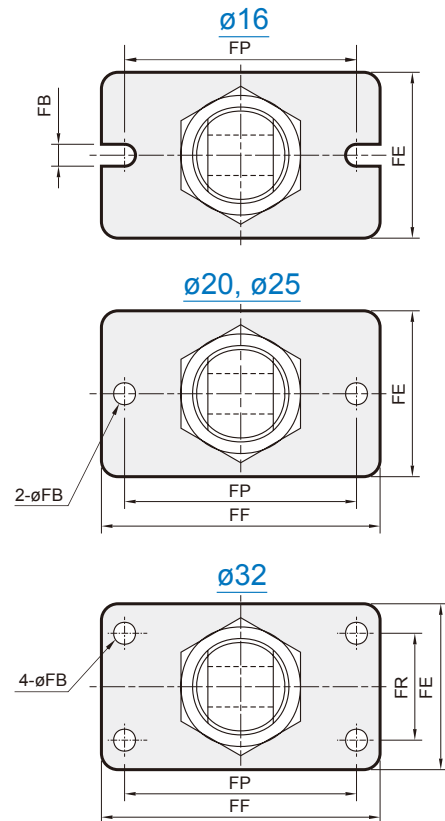
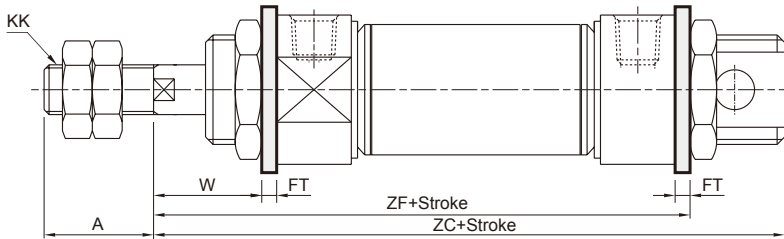

Code Stroke Tube I.D.	ZC						ZF							
	15	25	50	75	100	125	150	15	25	50	75	100	125	150
16	121	131	171	211	251	—	—	109.2	119.2	159.2	199.2	239.2	—	—
20	146	156	206	256	306	356	406	132.5	142.5	192.5	242.5	292.5	342.5	392.5
25	155	165	215	265	315	365	415	141.5	151.5	201.5	251.5	301.5	351.5	401.5
32	162	172	222	272	322	372	422	144.5	154.5	204.5	254.5	304.5	354.5	404.5

Code Tube I.D.	A	FB	FE	FF	FP	FR	FT	KK	W
16	16	5.5	26	52	40	—	3.2	M6×1.0	18.8
20	20	6.6	38	64	50	—	4.5	M8×1.25	13.5
25	22	6.6	38	64	50	—	4.5	M10×1.25	22.5
32	22	6.6	47	72	58	33	4.5	M10×1.25	25.5

SDB

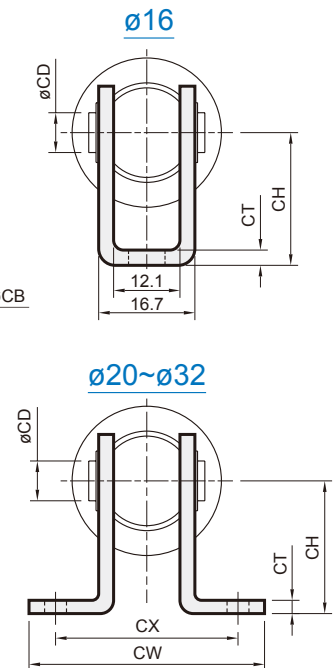
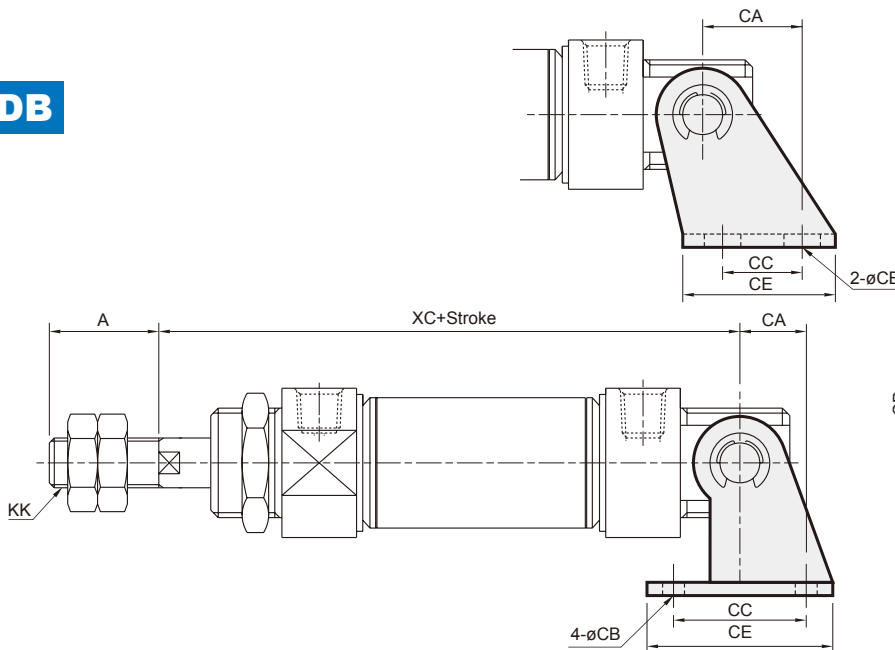

Code Stroke Tube I.D.	A	CA	CB	CC	CD	CE	CH	CT	CW	CX	KK
16	16	15	5.5	12	6	23	20	2.3	—	—	M6×1.0
20	20	16	6.6	32	8	48	32	3.2	67	51	M8×1.25
25	22	16	6.6	32	8	48	32	3.2	67	51	M10×1.25
32	22	18	6.6	36	10	52	36	4	67	51	M10×1.25

Code Stroke Tube I.D.	XC						
	15	25	50	75	100	125	150
16	107	117	157	197	257	—	—
20	139	149	199	249	299	349	399
25	141	151	172	222	272	322	372
32	142	152	173	223	273	323	373

## MINIATURE CYLINDER

### Y connector

$\varnothing 8 \sim \varnothing 16$

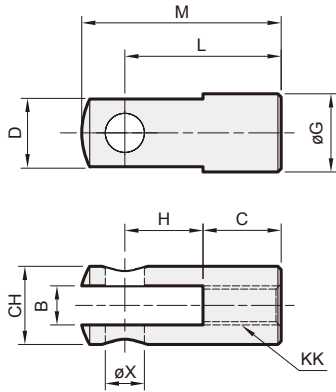

$\varnothing 20 \sim \varnothing 40$

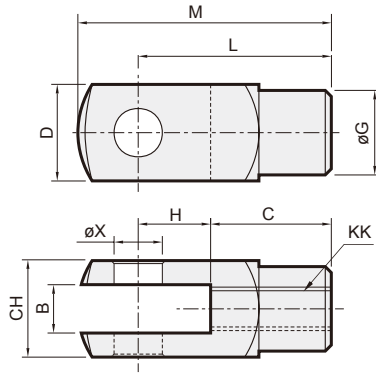

### I connector

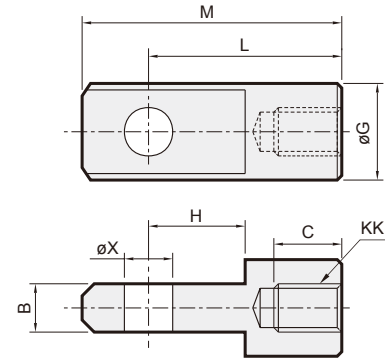

Code Tube I.D.	B		C		CH		D		G		H		KK		L		M		X <sup>H9</sup>
	Y	I	Y	I	Y	I	Y	I	Y	I	Y	I	Y	I	Y	I	Y	I	
8,10	4 <sup>+0.4</sup> <sub>+0.1</sub>	—	8	—	8	—	8	—	—	—	8	—	M4×0.7	—	16	—	20.75	—	4 <sup>+0.03</sup> <sub>+0</sub>
12,16	6 <sup>+0.4</sup> <sub>+0.1</sub>	6 <sup>-0.2</sup> <sub>-0.3</sub>	12	8	12	—	—	—	12	12	12	10	M6×1.0	—	24	21	31	28	6 <sup>+0.03</sup> <sub>+0</sub>
20	8 <sup>+0.5</sup> <sub>+0.15</sub>	8 <sup>-0.1</sup> <sub>-0.2</sub>	16	14	16	—	16	—	14	16	16	12	M8×1.25	—	32	32	42	42	8 <sup>+0.036</sup> <sub>+0</sub>
25,32	10 <sup>+0.5</sup> <sub>+0.15</sub>	10 <sup>-0.1</sup> <sub>-0.2</sub>	20	17	19	—	19	—	18	20	20	15	M10×1.25	—	40	40	52	52	10 <sup>+0.036</sup> <sub>+0</sub>
40	12 <sup>+0.5</sup> <sub>+0.15</sub>	12 <sup>-0.1</sup> <sub>-0.2</sub>	24	21	22	—	22	—	20	24	24	18	M12×1.25	—	48	48	62	62	12 <sup>+0.043</sup> <sub>+0</sub>

### PIN

\* Only for Y connector and  $\varnothing 20 \sim 40$  tube I.D.  
\*  $\varnothing 16$  tube I.D. use this order: **YS-MCMA-16** & **YS-MCM1-16**.

### Order example

**PIN — MCMA — 16 — Y — P**

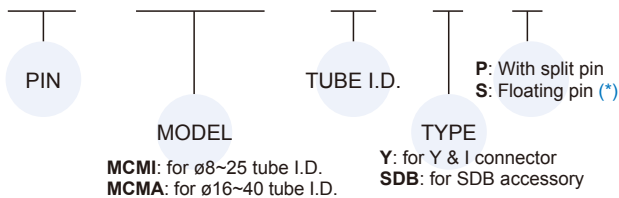

$\varnothing 8 \sim \varnothing 16$

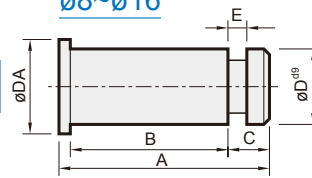

$\varnothing 20 \sim \varnothing 40$

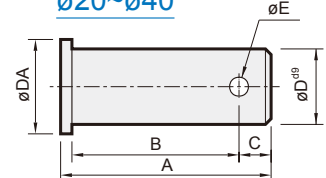

### for Y & I connector

Code Tube I.D.	A	B	C	D <sup>g9</sup>	DA	E	Split pin
8,10	12	8.5	2	4 <sup>-0.03</sup> <sub>-0.06</sub>	8	0.7	E3
12,16	18.5	15	2	6 <sup>-0.03</sup> <sub>-0.06</sub>	10	0.7	E4
20	24.5	20.5	2.5	8 <sup>-0.04</sup> <sub>-0.08</sub>	12	$\varnothing 2.5$	2.5×16L
25,32	30	25	3.5	10 <sup>-0.04</sup> <sub>-0.08</sub>	14	$\varnothing 3.2$	3.2×20L
40	37	30	5	12 <sup>-0.05</sup> <sub>-0.09</sub>	16	$\varnothing 3.2$	3.2×20L

### S

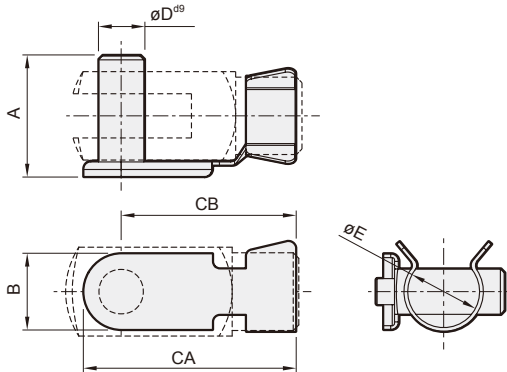

### for floating pin

Code Tube I.D.	A	B	CA	CB	D <sup>g9</sup>	E
16	16	10	28	23	$\varnothing 6$ <sup>-0.03</sup> <sub>-0.06</sub>	9.5
20	22	12	37	31	$\varnothing 8$ <sup>-0.04</sup> <sub>-0.08</sub>	13.5
25,32	26	14	45	38	$\varnothing 10$ <sup>-0.04</sup> <sub>-0.08</sub>	17
40	31	16	54	46	$\varnothing 12$ <sup>-0.05</sup> <sub>-0.09</sub>	19

### P

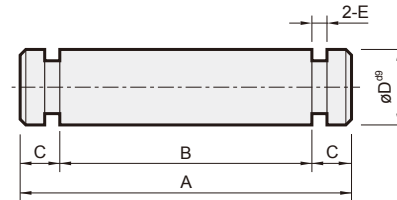

### for SDB

Code Tube I.D.	A	B	C	D <sup>g9</sup>	E	Split pin
8,10	18	14	2	4 <sup>-0.03</sup> <sub>-0.06</sub>	0.7	E3.2
12	23.5	19.5	2	6 <sup>-0.03</sup> <sub>-0.06</sub>	0.7	E5
16	21	17	2	6 <sup>-0.03</sup> <sub>-0.06</sub>	0.7	E5
20,25	30	25	2.5	8 <sup>-0.04</sup> <sub>-0.08</sub>	0.9	E7
32	33	27	3	10 <sup>-0.04</sup> <sub>-0.08</sub>	0.9	E9
40	37	31	3	12 <sup>-0.05</sup> <sub>-0.09</sub>	0.9	E9