

### Features

- Rack and pinion construction enable synchronisation of both jaws enabling smooth and consistent gripping force.
- Wide range of strokes available.
- Dust seals protect all internal parts from ingress of dirt.
- Proximity and reed switches can be used with this unit.
- Magnetic as standard.

### Specification

Model	MCHX				
Acting type	Double acting				
Tube I.D. (mm)	10	16	20	25	32
Stroke	20,40,60	30,60,80	40,80,100	50,100,120	70,120,160
Medium	Air				
Operating pressure range	0.2~0.6 MPa				
Ambient temperature	-5~+60°C (No freezing)				
Lubrication (*1)	Not required				
Repeatability	±0.1 mm				
Sensor switch (*2)	RDF(V), RNF(V): NPN, RPF(V): PNP				

### Order example

**MCHX - 16 - 30 M**

MODEL

TUBE I.D.	STROKE
10	20, 40, 60
16	30, 60, 80
20	40, 80, 100
25	50, 100, 120
32	70, 120, 160

M: Magnet

\* Magnetic as standard.

\*1. Maintenance: Re-Lubrication after appr. 1.5 million cycles recommended.

\*2. RDF specification, please refer to page 5-10.

### Weight

Model	MCHX-10			MCHX-16			MCHX-20			MCHX-25			MCHX-32		
Stroke (mm)	20	40	60	30	60	80	40	80	100	50	100	120	70	120	160
Max. operating frequency (c.p.m)	60	40	40	60	40	40	60	40	40	60	40	40	30	20	20
Weight (kg)	0.28	0.35	0.44	0.56	0.8	0.94	1.0	1.5	1.68	1.69	2.8	3.0	3.15	4.36	5.02

### Mounting

#### Axial mounting

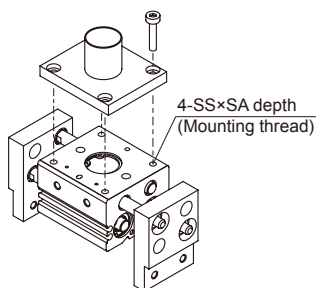

Model	SA	SS	Max. tightening torque (N.m)
MCHX-10	8	M4×0.7	2.1
MCHX-16	10	M5×0.8	4.3
MCHX-20	12	M6×1.0	7.3
MCHX-25	16	M8×1.25	17.7
MCHX-32	16	M8×1.25	18

#### Axial mounting

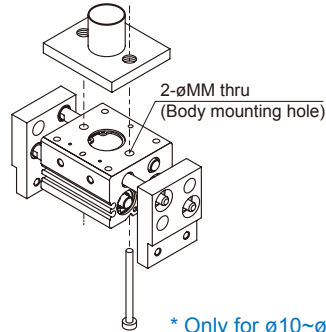

\* Only for ø10~ø25.

Model	MM	Bolt	Max. tightening torque (N.m)
MCHX-10	4.5	M4×0.7	2.1
MCHX-16	5.5	M5×0.8	4.3
MCHX-20	6.6	M6×1.0	7.3
MCHX-25	9	M8×1.25	17.7
MCHX-32	—	—	—

#### Lateral mounting

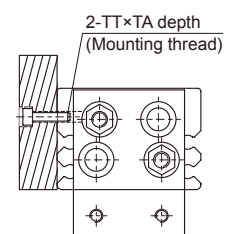

Model	TA	TT	Max. tightening torque (N.m)
MCHX-10	5	M4×0.7	1.4
MCHX-16	7	M5×0.8	2.8
MCHX-20	7	M6×1.0	4.8
MCHX-25	7	M8×1.25	12
MCHX-32	11	M8×1.25	12

## WIDE TYPE PARALLEL GRIPPER (2-Finger)

ø10

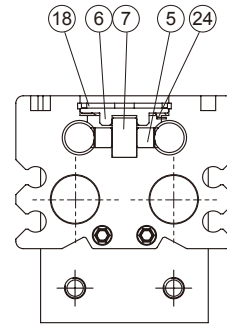
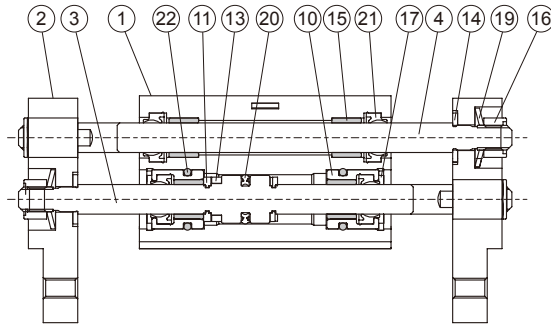

ø16~ø32

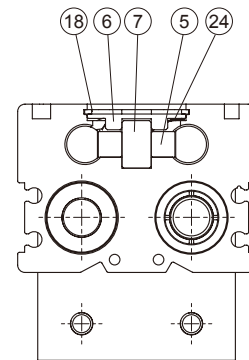
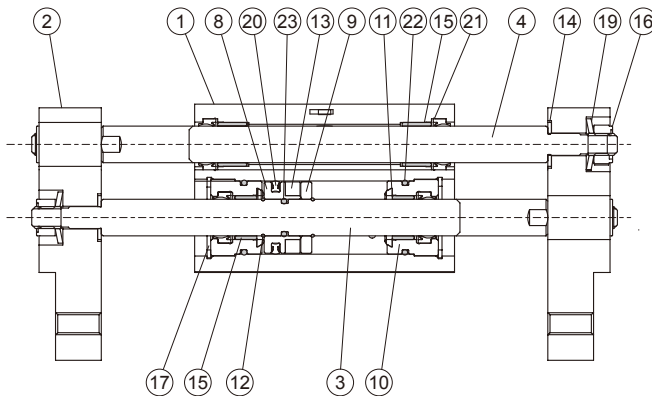

### Material

No.	Tube I.D. Part name	10	16	20	25	32	Q'y	Repair kits (inclusion)
1	Body	Aluminum alloy					1	
2	Finger	Aluminum alloy					2	
3	Piston rod	Stainless steel					2	
4	Rack	Stainless steel					2	
5	Pinion	Carbon steel					1	
6	Pinion cover	Carbon steel					1	
7	Pinion axis	Stainless steel					1	
8	Piston	—	Brass			2		
9	Magnet holder	—	Brass			2		
10	Rod cover	Aluminum alloy					4	
11	Damper	NBR	PU	NBR		4	●	
12	Stop ring	—	Spring steel	*1	*2	4		
13	Magnet	Magnet material					2	
14	Washer	Stainless steel		Carbon steel		4		
15	Bearing	Oil containing polyacetal with back metal					8	
16	U nut	Carbon steel					4	
17	R-shape snap ring	*3	*1	Carbon steel		4		
18	C-shape snap ring	Carbon steel					1	
19	Conical spring washer	Stainless steel					4	
20	Piston packing	NBR					2	●
21	Rod packing	NBR					8	●
22	O-ring	NBR					4	●
23	O-ring	—	NBR			2		
24	Wave washer	Carbon steel					1	

### Order example of repair kits

Tube I.D.	Repair kits
ø10	<b>PS-MCHX-10</b>
ø16	<b>PS-MCHX-16</b>
ø20	<b>PS-MCHX-20</b>
ø25	<b>PS-MCHX-25</b>
ø32	<b>PS-MCHX-32</b>

\*1. Stainless steel

\*2. Spring steel

\*3. Carbon steel

### Model selection example

\* Finger selection please refer to page 3-2.

In the motion process did not produce high acceleration, deceleration or impact forces, Workpiece mass: 0.3kg , Gripping method: External gripping, Operating pressure: 0.5 MPa, Coefficient of friction ( $\mu$ ): 0.1, Holding position: L=20mm (no overhang)

- Based on the above formula, the required gripping force can be derived:
 
$$F \geq \frac{0.3 \times 9.8}{2 \times 0.1} \times 4 \geq 60(N)$$
- From Effective Gripping Force Fig. Operating pressure: 0.5 MPa; Holding position: 20 mm Effective gripping force is greater than 60 (N) So selected **MCHX-20-40** grippers.

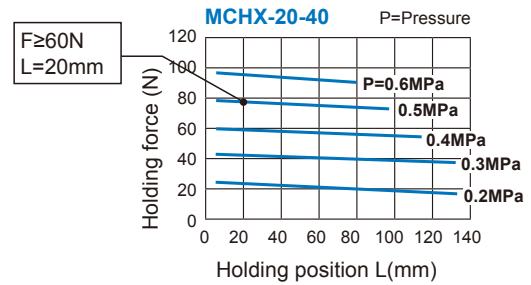

### Model selection suggestions

- For normal gripping and carrying usage, the recommended safe factor (a) is 4.
- The value of gripping force of single finger can be found at the gripping force table.
- The safe factor (a) have to be higher if the gripper is using with a great accelerated velocity or impaction condition.

### Mounting precautions

- To prevent bending the piston rod, please mount the attachment when finger is closing.
- Do not scratch or dent the sliding portion of the piston rod, or it may cause air leaks or faulty operation.
- Refer to the table below for the proper tightening torque on the bolt used for securing the attachment to the finger.

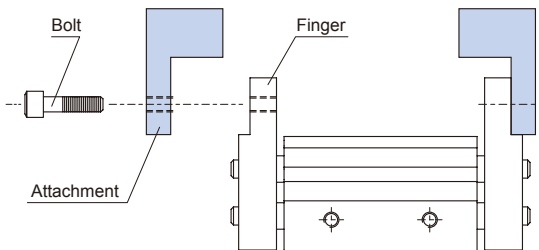

Model	Bolt	Max. tightening torque (N.m)
<b>MCHX-10</b>	M4×0.7	1.4
<b>MCHX-16</b>	M5×0.8	2.8
<b>MCHX-20</b>	M6×1.0	4.8
<b>MCHX-25</b>	M8×1.25	12
<b>MCHX-32</b>	M10×1.5	24

### Effective gripping force

Indication of effective force.

The effective gripping force shown in the graphs to the right is expressed as F, which is the thrust of one finger, when both fingers and attachments are in full contact with the workpiece as shown in the figure below.

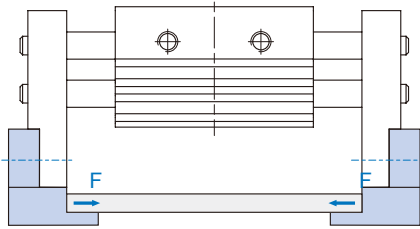

1N=0.102 kgf  
1MPa=10.2 kgf/cm<sup>2</sup>

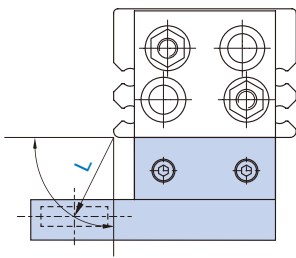

L: Holder position (mm)

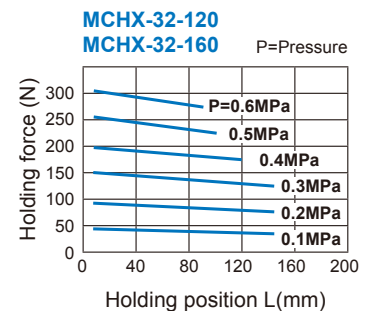
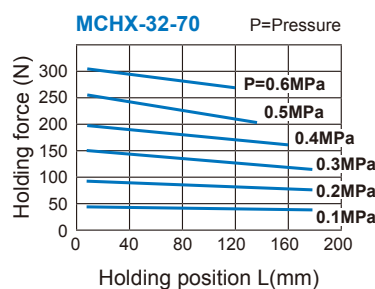
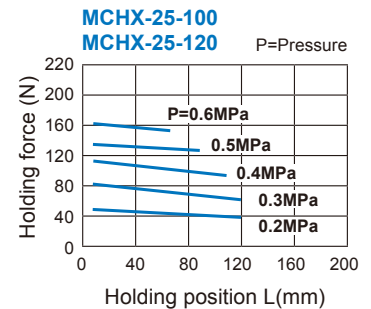
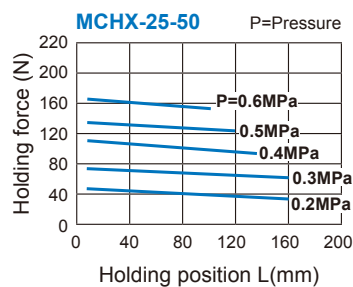
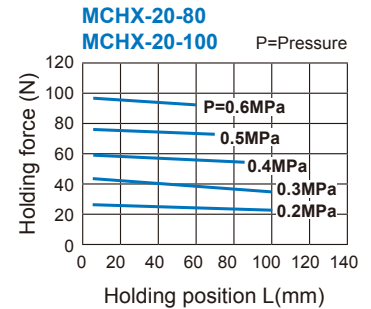
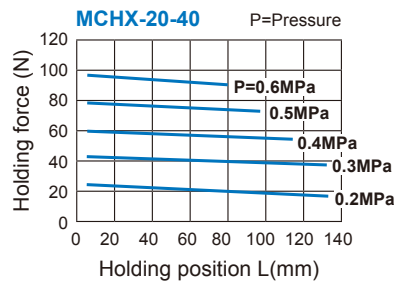
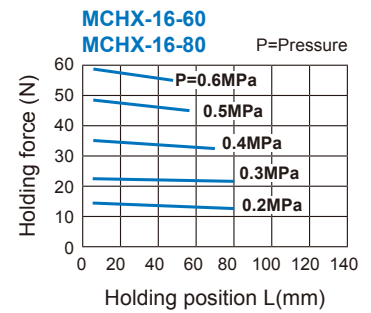
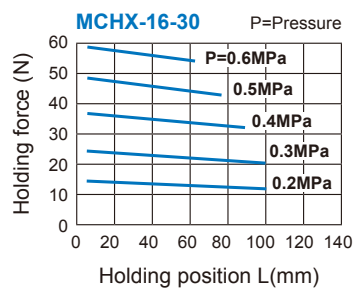
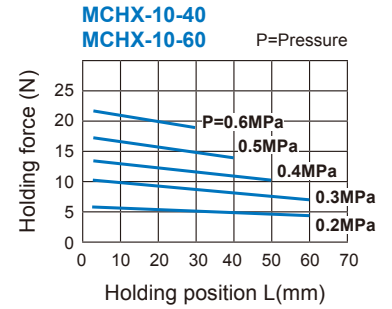
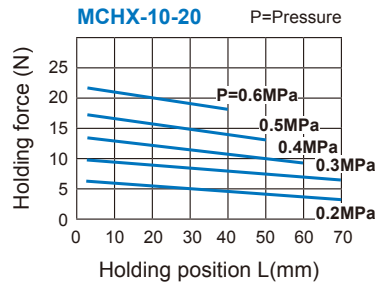

## WIDE TYPE PARALLEL GRIPPER (2-Finger)

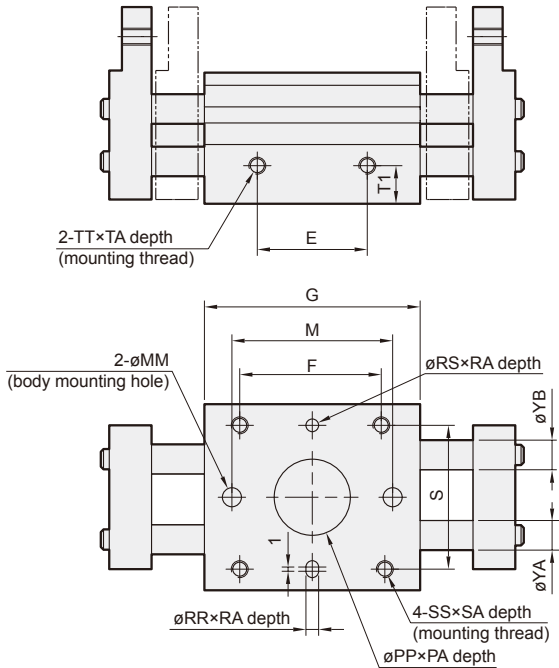

Code Model	Stroke	A	B	DA	DB	E	F	G	M	P1	P2
MCHX-10	20	76	56	100	80	26	36	51	38	11.5	11.5
	40	118	78	142	108	42	52	67	54	19.5	19.5
	60	156	96	180	146	60	70	85	72	28.5	28.5
MCHX-16	30	98	68	128	98	28	45	60	40	13	13
	60	170	110	200	152	58	75	90	70	25	25
	80	210	130	240	192	78	95	110	90	35	35
MCHX-20	40	122	82	160	120	38	58	71	54	16	16
	80	222	142	260	194	80	100	113	96	34	34
	100	262	162	300	234	100	120	133	116	44	44
MCHX-25	50	150	100	196	146	48	70	88	66	19	19
	100	282	182	328	244	102	124	142	120	43	43
	120	320	200	366	282	120	142	160	138	52	52
MCHX-32	70	220	150	272	202	60	86	110	-	28	28
	120	318	198	370	282	108	134	158	-	52	52
	160	402	242	454	366	152	178	202	-	74	74

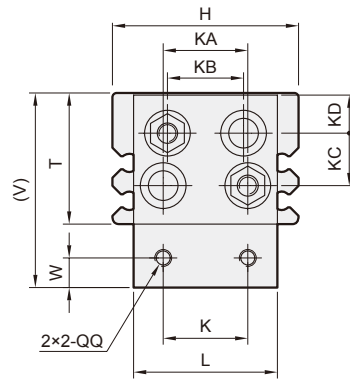
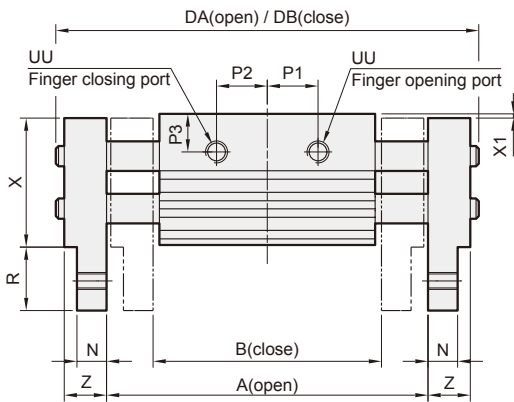

Code Model	H	K	KA	KB	KC	KD	L	N	MM	PA	PP	P3	QQ	R	RA	RR	RS	S	SA	SS
MCHX-10	44	20	20	18.2	12.5	8	34	7	4.5	1.5	18	9	M4×0.7	15	3	3	3	34	8	M4×0.7
MCHX-16	55	25	25	22.6	16.5	9	43	9	5.5	1.5	23	10	M5×0.8	19	3	3	3	42	10	M5×0.8
MCHX-20	65	30	30	28.2	20	10	54	12.5	6.6	1.5	24	11	M6×1.0	24	4	4	4	52	12	M6×1.0
MCHX-25	76	40	38	33.2	23.5	11.5	64	14	9	1.5	32	16	M8×1.25	29	4.5	4	4	62	16	M8×1.25
MCHX-32	82	50	40	32.2	30	14.5	70	15	-	2.5	35	16	M10×1.5	32	8	6	6	64	16	M8×1.25

Code Model	T	T1	TA	TT	UU	V	W	X	X1	YA	YB	Z
MCHX-10	31	9	5	M4×0.7	M5×0.8	46	7	30.5	0.5	6	6	10
MCHX-16	39	10	7	M5×0.8	M5×0.8	58	8	38.5	0.5	8	8	13
MCHX-20	46	11	7	M6×1.0	M5×0.8	70	10	45	1	10	10	17
MCHX-25	52	12.5	7	M8×1.25	M5×0.8	81	12	51	1	12	12	21
MCHX-32	68	22	11	M8×1.25	Rc1/8	100	15	67	1	14	16	24