



### Features

- Multi-ports as standard enabling both direction mounting.
- Non-rotating accuracy  $\pm 0.1^\circ$
- Embedding type sensors.
- The sensor cable will be in the same direction as the piping tube if vertical type sensor switch (Angle cable) is used.
- Magnetic as standard.

### Specification

Model	MCGS	
Acting type	Double acting	
Tube I.D. (mm)	6	10
Stroke (mm)	5, 10, 15	5, 10, 15, 20
Port size	M3 $\times$ 0.5	
Medium	Air	
Max. operating pressure	0.7 MPa	
Min. operating pressure	0.15 MPa	
Proof pressure	1 MPa	
Lubrication	Not required	
Ambient temperature	-5~+60°C (No freezing)	
Available speed range	50~400 mm/sec	
Sensor switch (*)	RDGV	

### Order example

**MCGS - 6 - 10**

MODEL

TUBE I.D.

STROKE

### Cylinder weight

Unit: g

Tube I.D.	Stroke (mm)			
	5	10	15	20
$\varnothing 6$	29	34	39	—
$\varnothing 10$	41	49	57	65

### Installation of sensor switch

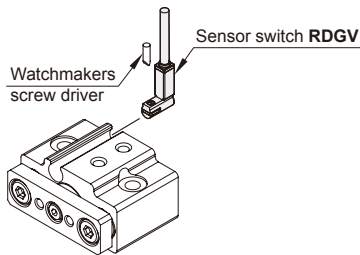

### Allowable rotational torque & Non-rotating accuracy

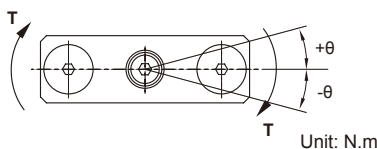

Tube I.D.	Stroke (mm)				Non-rotating accuracy $\theta$
	5	10	15	20	
$\varnothing 6$	0.9	0.7	0.6	—	$\pm 0.15^\circ$
$\varnothing 10$	4.7	3.9	3.3	2.8	

### Allowable lateral load

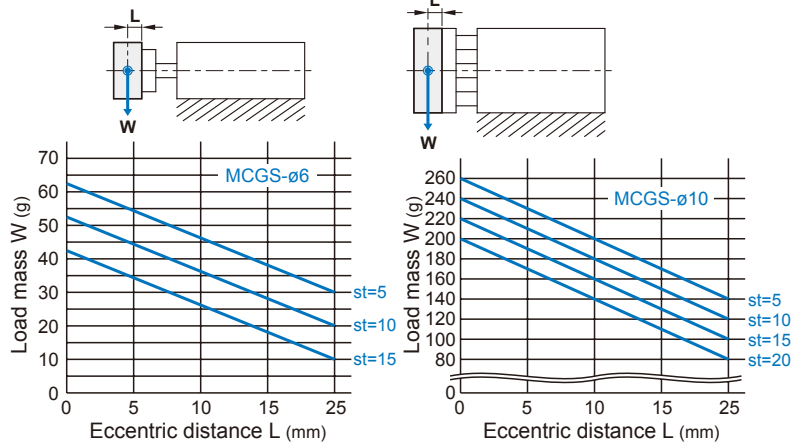

### Allowable eccentric load

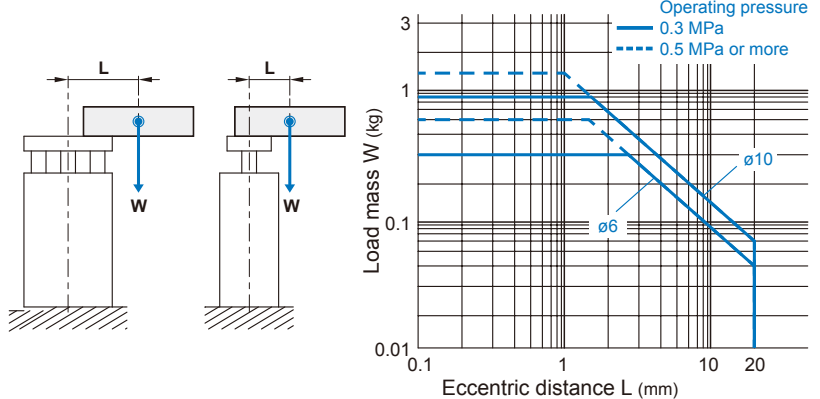

\*1. RDGV specification, please refer to page 8-16.

\*2. This product is not applicable for stopper purpose.

## TWIN-GUIDE CYLINDER

Mindman

### Inside structure & Parts list

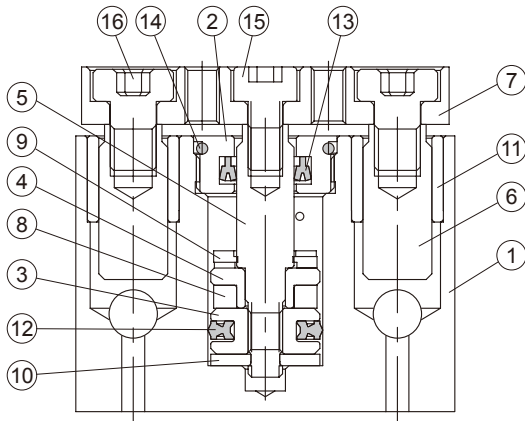

### Material

No.	Part name	Material	Q'y	Repair kits (inclusion)
1	Body	Aluminum alloy	1	
2	Rod cover	Aluminum alloy	1	
3	Piston- H	Aluminum alloy	1	
4	Piston- R	Aluminum alloy	1	
5	Piston rod	Stainless steel	1	
6	Guide rod	Carbon steel	2	
7	Plate	Aluminum alloy	1	
8	Magnet ring	Magnet material	1	
9	Cushion	NBR	1	●
10	Cushion	NBR	1	●
11	Bush	Copper	2	
12	Piston seal	NBR	1	●
13	Rod seal	NBR	1	●
14	O ring	NBR	1	●
15	Screw	Carbon steel	1	
16	Screw	Carbon steel	2	

### Order example of repair kits

Tube I.D.	Repair kits
$\varnothing 6$	<b>PS-MCGS-6</b>
$\varnothing 10$	<b>PS-MCGS-10</b>

### Dimensions

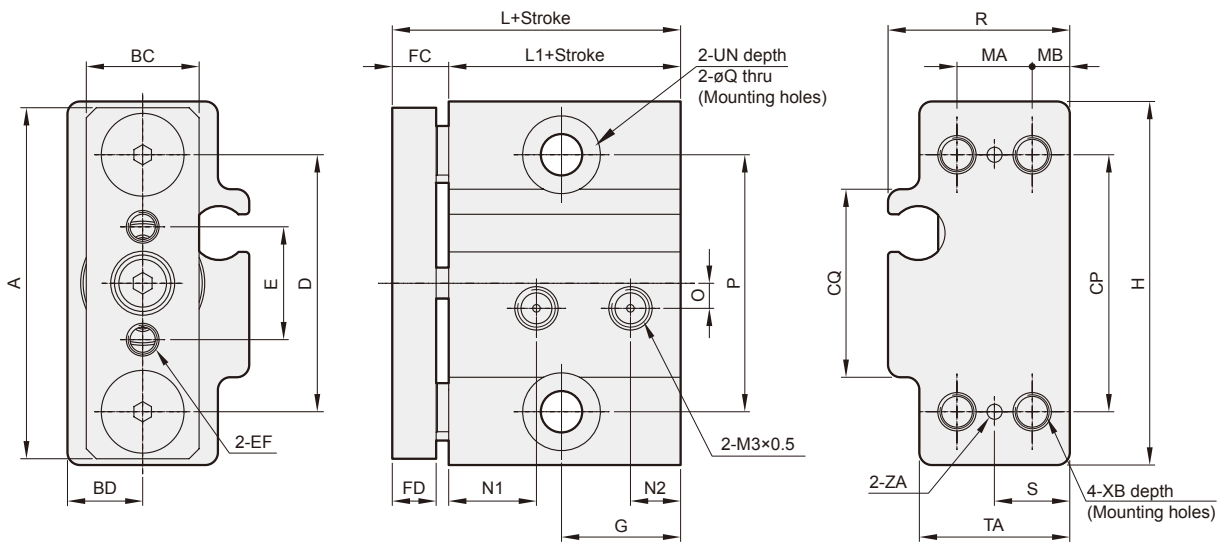

Code Tube I.D.	A	BC	BD	CP	CQ	D	E	EF	FC	FD	G	H	L	L1	MA	MB	N1	N2
6	28	9	6	20.5	15	20.5	9	M2.5×0.45 thru	4.5	3.5	9.5	29	23	18.5	6	3	7	4
10	32	10	7.5	23	17.5	23	11	M3×0.5 thru	6	5	8.5	33	25	19	8	3.5	7	4.5

Code Tube I.D.	O	P	Q	R	S	TA	UN	XB	ZA
6	2	20.5	3.3	14.5	6	12	$\varnothing 6.2 \times 0.5$	M3×0.5×5	$\varnothing 1.2$
10	3	23	4.3	17	7.5	15	$\varnothing 8 \times 0.5$	M4×0.7×5	$\varnothing 2$



### Features

- Proven track record in manufacturing precision guided cylinders.
- Multi-Ports as standard enabling two direction mounting option.
- Flush fitting sensors.
- Inbuilt high density rubber pad absorbs energy at the end of stroke.
- Magnetic as standard

### Specification

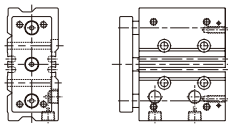
Model	MCGS		
Model			
Acting type	Double acting		
Tube I.D. (mm)	12,16	20,25,32,40	50,63
Port size	M5×0.8	Rc1/8	Rc1/4
Medium	Air		
Operating pressure range	0.1~1 MPa		
Proof pressure	1.5 MPa		
Ambient temperature	-5~+60°C (No freezing)		
Cushion	With rubber cushion pad		
Available speed range	50~500 mm/sec		
Lubrication	Not required		
Sensor switch (*)	RCE, RCE1, RDEP		

### Order example

**MCGS - 03 - 12 - 50 - 20 - G**

MODEL

TUBE I.D.

STROKE

ADJUST STROKE  
(for 07, 27 type)

PORT THREAD  
Blank: M5×0.8  
(for  $\varnothing 12, \varnothing 16$ )  
Blank: Rc thread  
G: G thread  
NPT: NPT thread  
(for  $\varnothing 20\sim\varnothing 63$ )

#### PURPOSE / TYPE OF BEARING

Code	Purpose / Type of bearing
03	Stop / Slide bush
07	Stop / Slide bush / Stroke adjustable
23	Push / Linear bearing (Could attach a table for the use as a lifter)
27	Push / Linear bearing / Stroke adjustable (Could attach a table for the use as a lifter)

\* RCE, RCE1, RDEP specification, please refer to page 8-10,14.

### Table for standard stroke

Series variety (Bearing type)	Tube I.D.	Stroke (mm)															
		10	20	25	30	40	50	75	100	125	150	175	200	250	300	350	400
MCGS-03 MCGS-07 (Slide bush)	$\varnothing 12$																
	$\varnothing 16$																
	$\varnothing 20$																
	$\varnothing 25$																
	$\varnothing 32^*$																
	$\varnothing 40$																
	$\varnothing 50$																
MCGS-23 MCGS-27 (Linear bearing)	$\varnothing 12$																
	$\varnothing 16$																
	$\varnothing 20$																
	$\varnothing 25$																
	$\varnothing 32^*$																
	$\varnothing 40$																
	$\varnothing 50$																
$\varnothing 63$																	

\* Tube I.D.  $\varnothing 32$ : 25mm for the shortest standard stroke.

### Installation of sensor switch

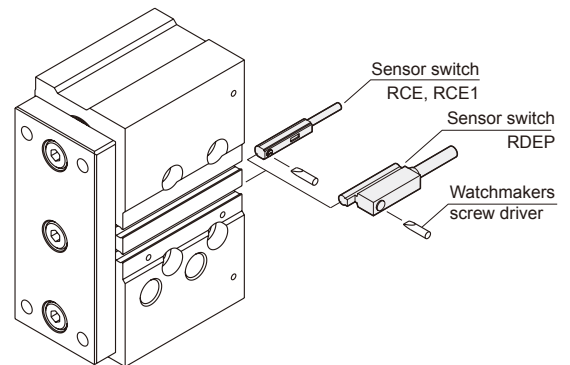

### Capacity graph

Capacity for the use as a stopper

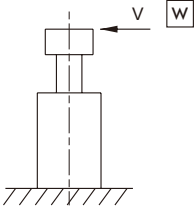

Linear bearing type is not available as a stopper.

### Stop capacity

MCGS-03/07...30st  $\phi 12 \sim \phi 32$

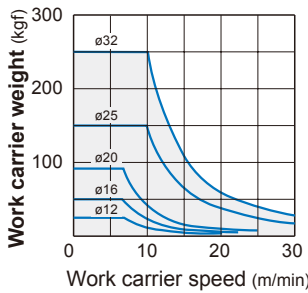

MCGS-03/07...25st  $\phi 40 \sim \phi 63$

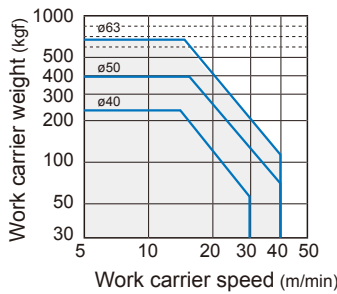

### Normal lateral load

MCGS-03/07...30st

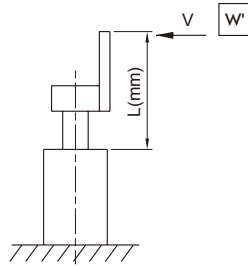
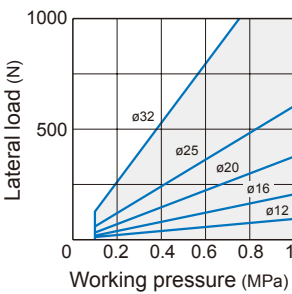

$$W = W' \times \frac{L}{\ell}$$

For the use of attaching a plate to the link bar, choose a bore size referring to the formula below.

**W:** The maximum weight of the work carrier in the above graph for the stopper's capacity.

### Coefficients for conversion

Tube I.D.	$\ell$
$\phi 12$	40
$\phi 16$	42
$\phi 20$	42
$\phi 25$	42
$\phi 32$	44
$\phi 40$	72
$\phi 50$	78
$\phi 63$	78

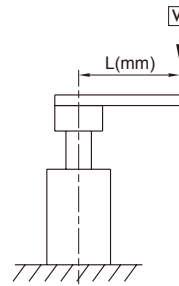

### Capacity for the use as a lifter

Allowable eccentricity load for the use as a lifter (at supply pressure 0.5 MPa)

Show the dynamic allowable value at L(mm) eccentricity from the center of the guide rod.

### Slide bush MCGS-03/07

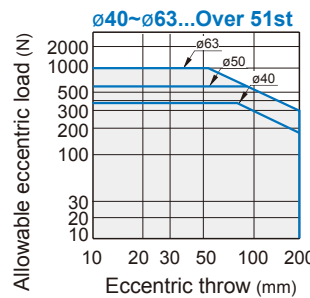
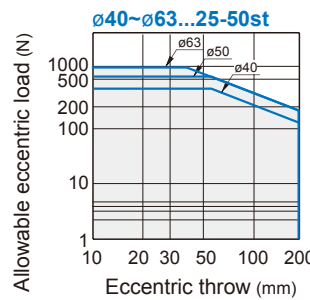
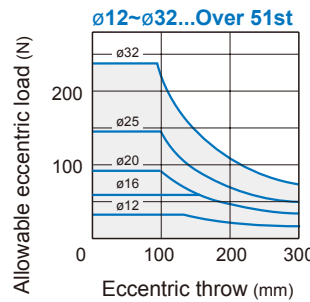
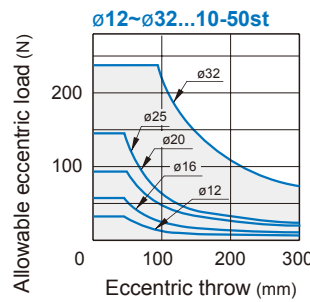

### Linear bearing MCGS-23/27

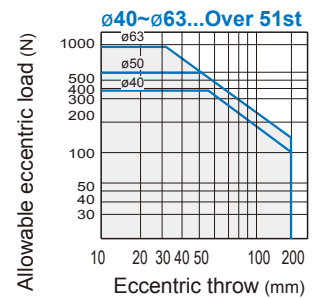
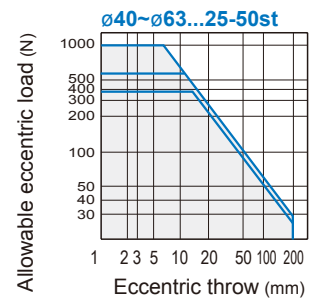
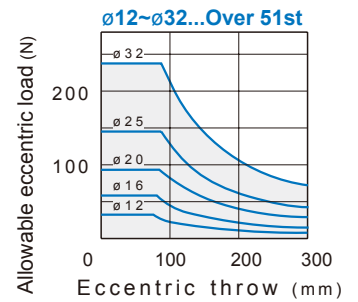
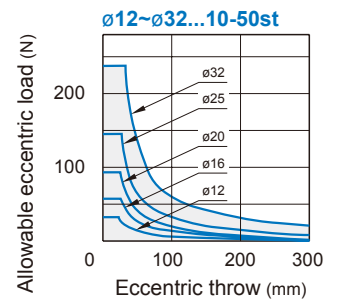

Unit: N

### Capacity table

#### Allowable lateral load

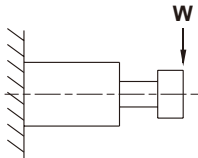

Shows the dynamic allowable value, when actuating the cylinder with lateral load  $W$  at the guide rods' top (vertical load against the guide rods).

Tube I.D.	Bearing type	Stroke (mm)															
		10	20	25	30	40	50	75	100	125	150	175	200	250	300	350	400
$\phi 12$	Slide bush	31	24	—	19	16	13	37	31	15	13	12	10	9	—	—	—
	Linear bearing	23	17	—	14	34	30	23	19	12	11	9	8	6	—	—	—
$\phi 16$	Slide bush	50	39	—	32	27	24	54	45	27	24	21	19	16	—	—	—
	Linear bearing	36	29	—	24	59	52	40	33	20	17	15	13	10	—	—	—
$\phi 20$	Slide bush	—	51	—	44	39	35	54	46	74	66	59	54	28	24	21	19
	Linear bearing	—	43	—	36	98	87	69	57	46	40	36	32	32	27	23	20
$\phi 25$	Slide bush	—	68	—	59	52	46	72	61	98	88	79	72	53	46	41	37
	Linear bearing	—	67	—	56	148	132	105	87	70	62	55	50	42	36	30	27
$\phi 32$	Slide bush	—	—	165	—	—	129	106	90	138	123	111	101	88	77	68	61
	Linear bearing	—	—	104	—	—	74	165	138	114	100	90	81	66	56	48	42
$\phi 40$	Slide bush	—	—	203	—	—	164	182	159	142	127	190	174	150	132	118	106
	Linear bearing	—	—	113	—	—	78	129	106	130	114	106	95	78	67	58	50
$\phi 50$	Slide bush	—	—	296	—	—	245	273	241	216	195	190	174	150	132	118	106
	Linear bearing	—	—	120	—	—	83	178	148	148	129	106	95	78	67	58	50
$\phi 63$	Slide bush	—	—	296	—	—	245	273	241	216	195	—	—	—	—	—	—
	Linear bearing	—	—	117	—	—	81	176	145	145	126	—	—	—	—	—	—

#### Allowable rotating torque

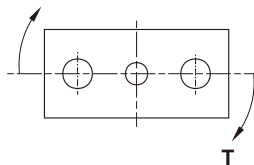

Shows the dynamic allowable value, when actuating the cylinder with a rotating torque  $T$  at the guide rods' top.

Unit: N.m

Tube I.D.	Bearing type	Stroke (mm)															
		10	20	25	30	40	50	75	100	125	150	175	200	250	300	350	400
$\phi 12$	Slide bush	0.64	0.48	—	0.39	0.32	0.28	0.75	0.63	0.15	0.13	0.12	0.11	0.09	—	—	—
	Linear bearing	0.47	0.35	—	0.29	0.71	0.62	0.40	0.38	0.13	0.11	0.09	0.08	0.07	—	—	—
$\phi 16$	Slide bush	1.14	0.90	—	0.74	0.63	0.55	1.23	1.04	0.31	0.27	0.24	0.22	0.18	—	—	—
	Linear bearing	0.84	0.66	—	0.54	1.35	1.19	0.93	1.76	0.23	0.19	0.17	0.15	0.12	—	—	—
$\phi 20$	Slide bush	—	1.14	—	1.21	1.07	0.95	1.49	1.25	2.03	1.81	1.63	1.48	0.37	0.32	0.29	0.26
	Linear bearing	—	1.19	—	0.99	2.69	2.40	1.89	1.56	1.26	1.10	0.98	0.88	0.43	0.36	0.31	0.27
$\phi 25$	Slide bush	—	2.19	—	1.88	1.65	1.47	2.31	1.94	3.15	2.80	2.52	2.30	0.85	0.74	0.66	0.59
	Linear bearing	—	2.14	—	1.79	4.74	4.22	3.36	2.78	2.25	1.98	1.76	1.59	0.68	0.57	0.49	0.42
$\phi 32$	Slide bush	—	—	6.61	—	—	5.16	4.23	3.59	5.52	4.93	4.45	4.06	1.72	1.50	1.33	1.20
	Linear bearing	—	—	4.17	—	—	2.95	6.60	5.52	4.56	4.02	3.59	3.24	1.29	1.09	0.94	0.82
$\phi 40$	Slide bush	—	—	7.00	—	—	5.66	6.27	5.48	4.87	4.38	5.21	4.79	4.13	3.63	3.23	2.92
	Linear bearing	—	—	5.24	—	—	4.25	7.19	6.33	7.81	7.11	2.93	2.61	2.16	1.83	1.58	1.39
$\phi 50$	Slide bush	—	—	13.0	—	—	10.8	12.0	10.6	9.50	8.60	5.88	5.41	4.66	4.09	3.65	3.29
	Linear bearing	—	—	7.02	—	—	5.76	12.3	10.9	11.2	10.2	3.30	2.94	2.43	2.06	1.78	1.57
$\phi 63$	Slide bush	—	—	14.7	—	—	12.1	13.5	12.0	10.7	9.69	—	—	—	—	—	—
	Linear bearing	—	—	7.77	—	—	3.35	13.7	12.2	12.5	11.4	—	—	—	—	—	—

#### Anti-roll accuracy

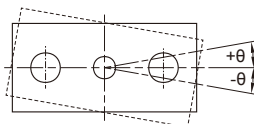

- The values are the deflection angle against the piston rod.
- Exclusive factor of the guide rods' deflection.

Tube I.D.	Bearing type	Anti-roll accuracy
		$\theta$
$\phi 12$	Slide bush	$\pm 0.09^\circ$
	Linear bearing	$\pm 0.06^\circ$
$\phi 16$	Slide bush	$\pm 0.08^\circ$
	Linear bearing	$\pm 0.06^\circ$
$\phi 20$	Slide bush	$\pm 0.08^\circ$
	Linear bearing	$\pm 0.03^\circ$
$\phi 25$	Slide bush	$\pm 0.07^\circ$
	Linear bearing	$\pm 0.05^\circ$
$\phi 32$	Slide bush	$\pm 0.07^\circ$
	Linear bearing	$\pm 0.03^\circ$
$\phi 40$	Slide bush	$\pm 0.06^\circ$
	Linear bearing	$\pm 0.08^\circ$
$\phi 50$	Slide bush	$\pm 0.05^\circ$
	Linear bearing	$\pm 0.06^\circ$
$\phi 63$	Slide bush	$\pm 0.05^\circ$
	Linear bearing	$\pm 0.06^\circ$

# MCGS-03 Inside structure & Parts list



## TWIN-GUIDE CYLINDER

Mindman

ø12~ø32

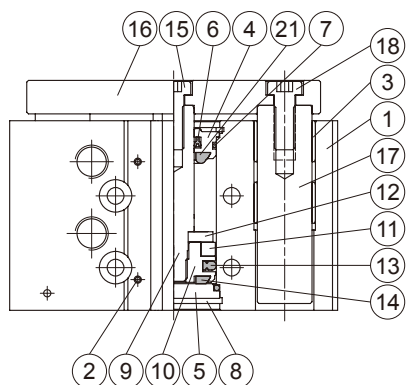

ø40~ø63

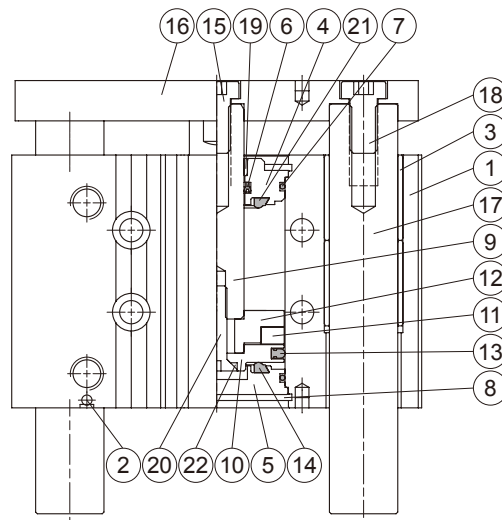

### Material

No.	Tube I.D. Part name	12	16	20	25	32	40	50	63	Q'ty	Repair kits (inclusion)
1	Body	Aluminum alloy								1	
2	Ball	Stainless steel								1	
3	Slide bush	Bronze alloy						Bearing alloy		4	
4	Rod cover	Aluminum alloy								1	
5	Head cover	(*)	Carbon steel			Aluminum alloy			1		
6	Rod packing	NBR								1	●
7	Cover ring	NBR								2	●
8	Snap ring	Spring steel								2	
9	Piston rod	Stainless steel		Carbon steel						1	
10	Piston	Aluminum alloy								1	
11	Magnet ring	Magnet material								1	
12	Magnet holder	Stainless steel				Aluminum alloy				1	
13	Piston packing	NBR								1	●
14	Head cushion	NBR								1	●
15	Bolt	SCM								1	
16	Plate	Carbon steel								1	
17	Guide rod	Carbon steel								2	
18	Screw	SCM								2	
19	Rod bush	—				Bearing alloy				1	
20	Piston bolt	—				SCM				1	
21	Rod cushion	NBR								1	●
22	Piston gasket	—				NBR				1	●

\* Aluminum alloy

### Order example of repair kits

Tube I.D.	Repair kits
ø12	<b>PS-MCGS-12</b>
ø16	<b>PS-MCGS-16</b>
ø20	<b>PS-MCGS-20</b>
ø25	<b>PS-MCGS-25</b>
ø32	<b>PS-MCGS-32</b>
ø40	<b>PS-MCGS-40</b>
ø50	<b>PS-MCGS-50</b>
ø63	<b>PS-MCGS-63</b>

### Cylinder weight

Unit: g

Model	Basic weight MCGS-03	Stroke 5mm MCGS-03
Tube I.D.		
ø12	191	21
ø16	283	28
ø20	450	45
ø25	670	63
ø32	1,210	90
ø40	1,474	88
ø50	2,540	140
ø63	3,295	151

# MCGS-07 Inside structure & Parts list



## TWIN-GUIDE CYLINDER

Mindman

ø12~ø16

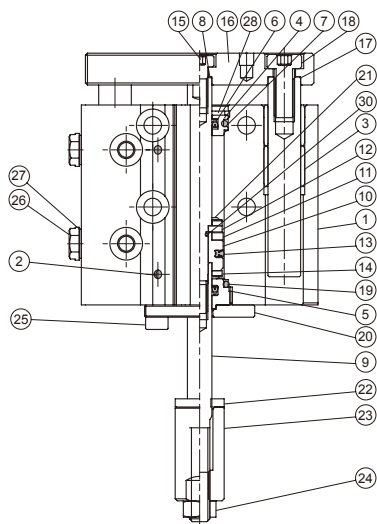

ø20~ø32

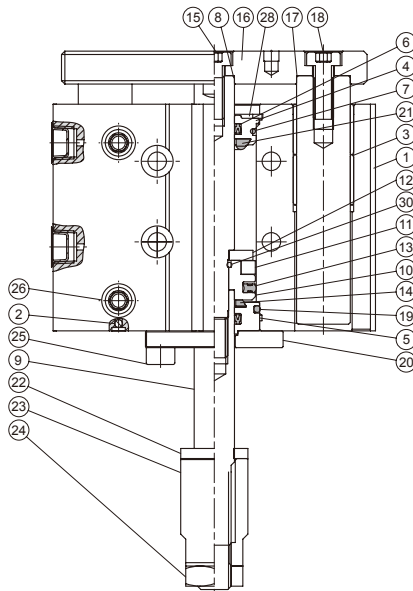

ø40~ø63

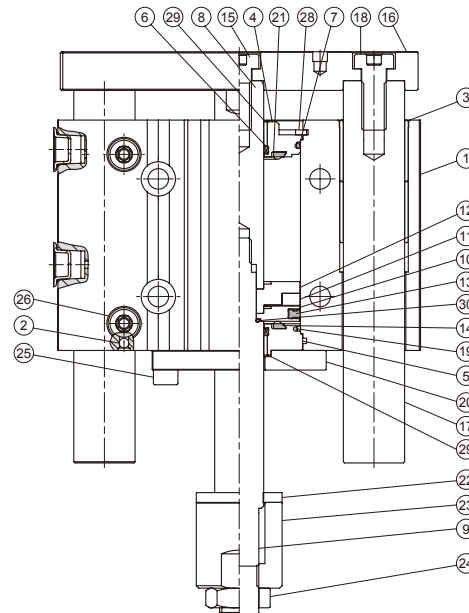

### Material

No.	Tube I.D. Part name	12	16	20	25	32	40	50	63	Q'y	Repair kits (inclusion)
1	Body	Aluminum alloy								1	
2	Ball	Stainless steel								1~3	
3	Slide bush	Bronze alloy						Bearing alloy		4	
4	Rod cover #1	Aluminum alloy								1	
5	Rod cover #2	Aluminum alloy								1	
6	Rod packing	NBR								2	●
7	Cover ring #1	NBR								1	●
8	Piston rod #1	Stainless steel	Carbon steel							1	
9	Piston rod #2	Stainless steel	Carbon steel							1	
10	Piston	Aluminum alloy								1	
11	Magnet ring	Magnet material								1	
12	Magnet holder	Stainless steel				Aluminum alloy				1	
13	Piston packing	NBR								1	●
14	Head cushion	NBR								1	●
15	Bolt	SCM								1	
16	Plate	Carbon steel								1	
17	Guide rod	Carbon steel								2	
18	Bolt	SCM								2	
19	Cover ring #2	NBR								1	●
20	FBC board	Carbon steel								1	
21	Rod cushion	NBR								1	●
22	Gasket	PU								1	
23	Adjustable nut	Carbon steel								1	
24	Nut	Carbon steel								1	
25	Bolt	Stainless steel	SCM							2	
26	Screw	Bronze alloy	Carbon steel (*)							2	
27	Washer	PET	—							2	
28	Snap ring	Spring steel								1	
29	Bush	—					Bearing alloy			2	
30	Piston gasket	NBR								1	●

### Order example of repair kits

Tube I.D.	Repair kits
ø12	PS-MCGS-2-12
ø16	PS-MCGS-2-16
ø20	PS-MCGS-2-20
ø25	PS-MCGS-2-25
ø32	PS-MCGS-2-32
ø40	PS-MCGS-2-40
ø50	PS-MCGS-2-50
ø63	PS-MCGS-2-63

\* The material changes into bronze alloy when the part thread is BSPF. (JISPF)

# MCGS-23 Inside structure & Parts list

## TWIN-GUIDE CYLINDER



ø12~ø32

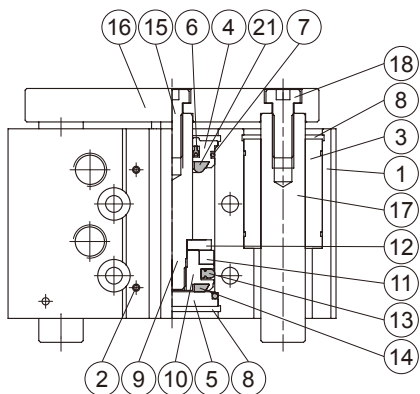

ø40~ø63

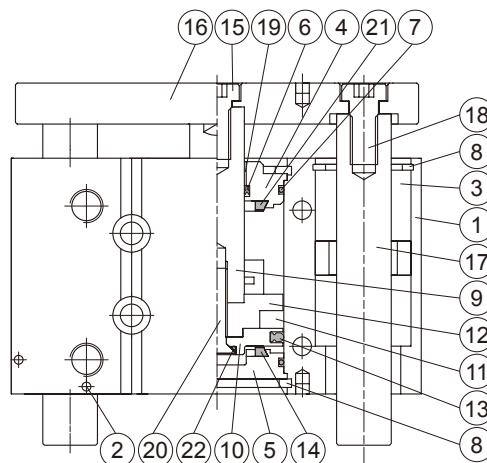

### Material

No.	Tube I.D. Part name	12	16	20	25	32	40	50	63	Q'y	Repair kits (inclusion)
1	Body	Aluminum alloy								1	
2	Ball	Stainless steel								1	
3	Linear bearing	—								2 or 4	
4	Rod cover	Aluminum alloy								1	
5	Head cover	(*)	Carbon steel			Aluminum alloy				1	
6	Rod packing	NBR								1	●
7	Cover ring	NBR								2	●
8	Snap ring	Spring steel								2	
9	Piston rod	Stainless steel		Carbon steel						1	
10	Piston	Aluminum alloy								1	
11	Magnet ring	Magnet material								1	
12	Magnet holder	Stainless steel			Aluminum alloy					1	
13	Piston packing	NBR								1	●
14	Head cushion	NBR								1	●
15	Bolt	SCM								1	
16	Plate	Carbon steel								1	
17	Guide rod	Special steel								2	
18	Screw	SCM								2	
19	Rod bush	—			Bearing alloy					1	
20	Piston bolt	—			SCM					1	
21	Rod cushion	NBR								1	●
22	Piston gasket	—			NBR					1	●

\* Aluminum alloy

### Order example of repair kits

Tube I.D.	Repair kits
ø12	<b>PS-MCGS-12</b>
ø16	<b>PS-MCGS-16</b>
ø20	<b>PS-MCGS-20</b>
ø25	<b>PS-MCGS-25</b>
ø32	<b>PS-MCGS-32</b>
ø40	<b>PS-MCGS-40</b>
ø50	<b>PS-MCGS-50</b>
ø63	<b>PS-MCGS-63</b>

### Cylinder weight

Unit: g

Model	Basic weight	
	MCGS-23	Stroke 5mm MCGS-23
Tube I.D.		
ø12	211	18
ø16	260	30
ø20	470	45
ø25	740	60
ø32	1,170	85
ø40	1,300	98
ø50	2,360	150
ø63	3,010	168



# MCGS-27 Inside structure & Parts list

## TWIN-GUIDE CYLINDER



ø12~ø16

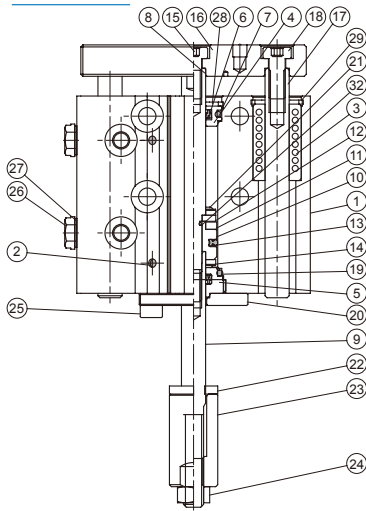

ø20~ø32

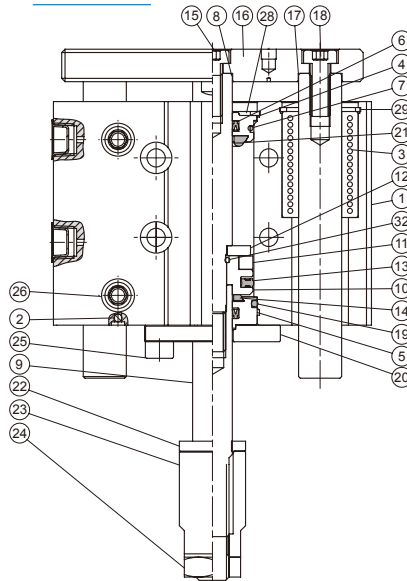

ø40~ø63

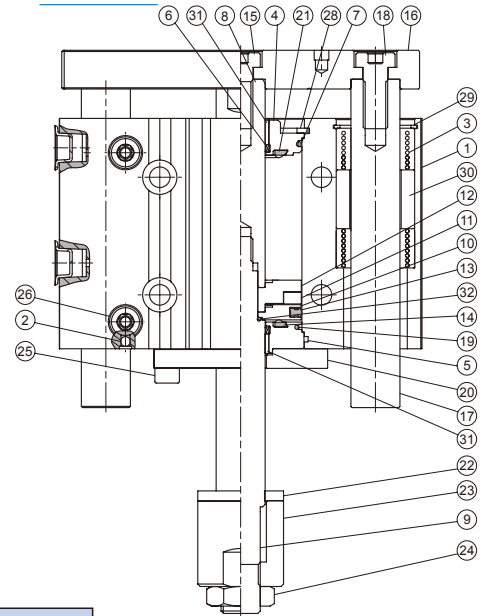

### Material

No.	Tube I.D. Part name	12	16	20	25	32	40	50	63	Q'y	Repair kits (inclusion)	
1	Body	Aluminum alloy								1		
2	Ball	Stainless steel								1~3		
3	Linear bearing	—								2 or 4		
4	Rod cover #1	Aluminum alloy								1		
5	Rod cover #2	Aluminum alloy								1		
6	Rod packing	NBR								2	●	
7	Cover ring #1	NBR								1	●	
8	Piston rod #1	Stainless steel		Carbon steel						1		
9	Piston rod #2	Stainless steel		Carbon steel						1		
10	Piston	Aluminum alloy								1		
11	Magnet ring	Magnet material								1		
12	Magnet holder	Stainless steel			Aluminum alloy					1		
13	Piston packing	NBR								1	●	
14	Head cushion	NBR								1	●	
15	Bolt	SCM								1		
16	Plate	Carbon steel								1		
17	Guide rod	Special steel								2		
18	Bolt	SCM								2		
19	Cover ring #2	NBR								1	●	
20	FBC board	Carbon steel								1		
21	Rod cushion	NBR								1	●	
22	Gasket	PU								1		
23	Adjustable nut	Carbon steel								1		
24	Nut	Carbon steel								1		
25	Bolt	Stainless steel		SCM							2	
26	Screw	Bronze alloy		Carbon steel (*2)							2	
27	Washer	PET		—							2	
28	Snap ring #1	Spring steel								1		
29	Snap ring #2	Spring steel								2		
30	Collar (*1)	Aluminum alloy		Carbon steel							2	
31	Bush	—			Bearing alloy					2		
32	Piston gasket	NBR								1	●	

### Order example of repair kits

Tube I.D.	Repair kits
ø12	PS-MCGS-2-12
ø16	PS-MCGS-2-16
ø20	PS-MCGS-2-20
ø25	PS-MCGS-2-25
ø32	PS-MCGS-2-32
ø40	PS-MCGS-2-40
ø50	PS-MCGS-2-50
ø63	PS-MCGS-2-63

\*1. Use for stroke 101 or more.

\*2. The material changes into bronze alloy when the part thread is BSPF. (JISPF)

# MCGS-03/23 Dimensions $\phi 12\sim\phi 32$

## TWIN-GUIDE CYLINDER

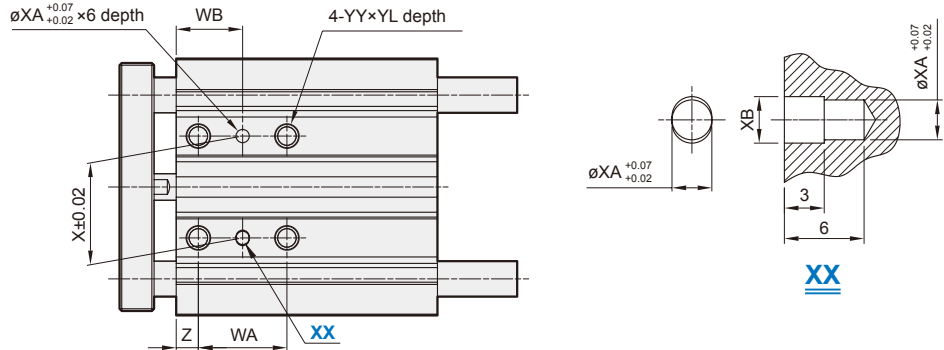

**Back side**

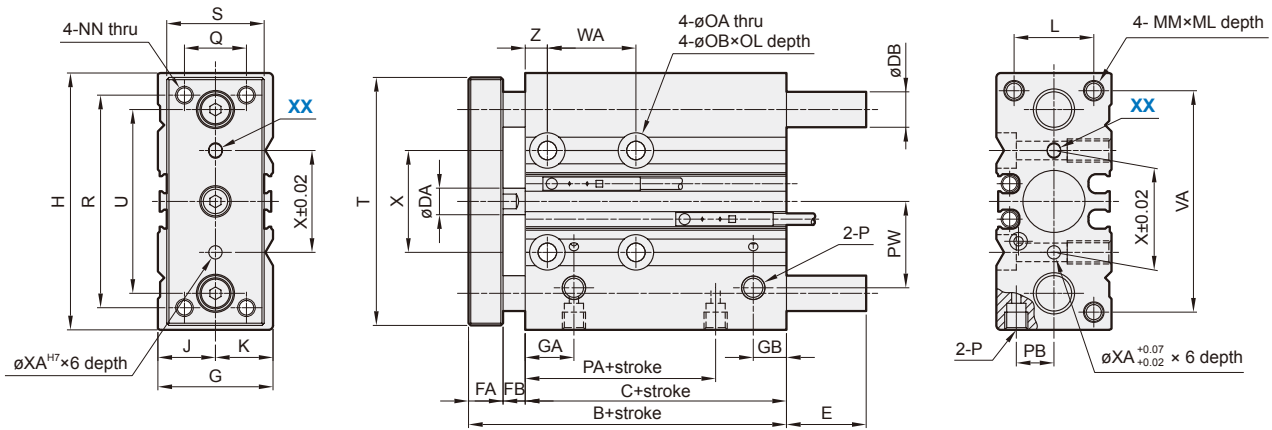

### MCGS-03 / MCGS-23

Code Tube I.D.	B	C	DA	DB		FA	FB	G	GA	GB	H	J	K	L	MM	ML	NN	OA	OB	OL	P	PA	PB
				03 type	23 type																		
12	42	29	6	8	6	8	5	26	11	15 <sup>(*1)</sup>	58	13	13	18	M4×0.7	10	M4×0.7	4.3	8.0	4.5	M5×0.8	14	8.5
16	46	33	8	10	8	8	5	30	11	18 <sup>(*2)</sup>	64	15	15	22	M5×0.8	12	M5×0.8	4.3	8.0	4.5	M5×0.8	15	10.0
20	53	37	10	12	10	10	6	36	10.5	8.5	85	17	19	24	M5×0.8	13	M5×0.8	5.2	9.5	5.5	Rc1/8	12.5	11.5
25	53.5	37.5	12	16	13	10	6	42	11.5	9	96	21	21	30	M6×1.0	15	M6×1.0	5.2	9.5	5.5	Rc1/8	12.5	13.5
32	59.5	37.5	16	20	16	12	10	51	12.5	9	116	26	25	34	M8×1.25	20	M8×1.25	6.6	11.0	7.5	Rc1/8	7	16.0

Code Tube I.D.	PW	Q	R	S	T	U	VA	X	XA	XB	YY	YL	Z
12	18	14	48	22	56	41.5	50	23	3	3.5	M5×0.8	10	5
16	19	16	54	25	62	46	56	24	3	3.5	M5×0.8	10	5
20	25	18	70	30	81	55	72	28	3	3.5	M6×1.0	12	17
25	28.5	26	78	38	91	65	82	34	4	4.5	M6×1.0	12	17
32	34	30	96	44	110	80	98	42	4	4.5	M8×1.25	16	21

Code Tube I.D.	WA					WB				
	~39st	40~100st	125~200st	201st~300st	301st~	20~39st	40~100st	125~200st	201~300st	301st~
12	20	40	110	200	—	15	25	60	105	—
16	24	44	110	200	—	17	27	60	105	—
20	24	44	120	200	300	29	39	77	117	167
25	24	44	120	200	300	29	39	77	117	167

Code Tube I.D.	WA					WB				
	25~49st	50~100st	125~200st	201st~300st	301st~	25~49st	50~100st	125~200st	201~300st	301st~
32	24	48	124	200	300	33	45	83	121	171

### MCGS-03

Code Tube I.D.	E		
	10~50st	51~100st	101st~
	10~50st	51~200st	201st~
12	—	18.5	43
16	—	18.5	49
20	—	31.5	69
25	—	31.5	68.5
32	37.5	42.5	80.5

### MCGS-23

Code Tube I.D.	E			
	10~30st	31~100st	101st~	
	20~30st	31~100st	101~200st	201st~
12	1	13	43	
16	3	19	49	
20	10	27	51	69
25	16	32	51	68.5
32	21.5	38.5	58.5	80.5

\*1. When stroke length is equal to 19mm or less, GB=7.5 mm

\*2. When stroke length is equal to 19mm or less, GB=9 mm

# MCGS-03/23 Dimensions $\phi 40\sim\phi 63$

## TWIN-GUIDE CYLINDER

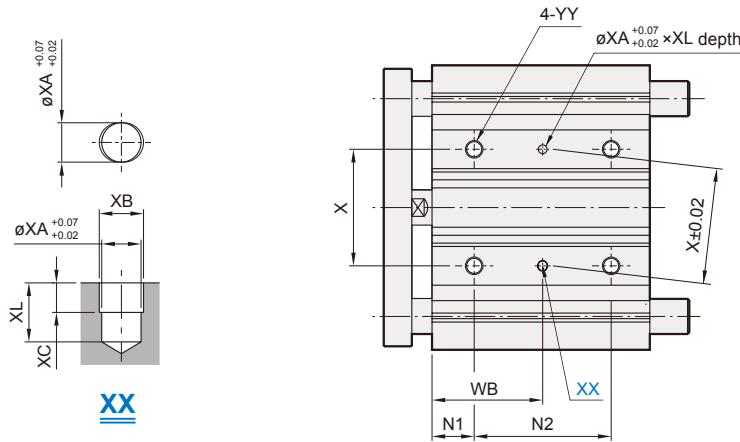

**XX**

**Back side**

**T slot for hexagon head bolt**

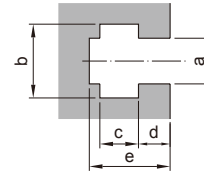

**T slot for hexagon head bolt**

Code Tube I.D.	a	b	c	d	e
40	6.5	10.5	5.5	4	11
50	8.5	13.5	7.5	4.5	13.5
63	11	17.8	10	7	18.5

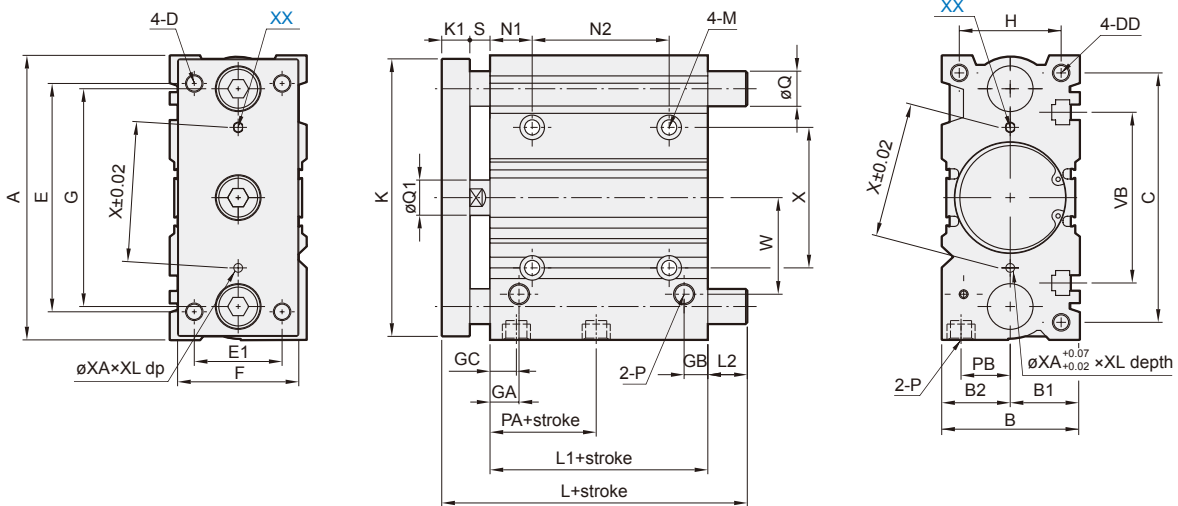

## MCGS-03 / MCGS-23

Code Tube I.D.	A	B	B1	B2	C	D	DD	E	E1	F	G	GA	GB	GC	H	K	K1	L1	M	N1	P
40	120	54	27	27	106	M8×1.25	M8×1.25×20 dp	104	30	44	86	14	10	14	40	118	12	44	$\phi 6.6$ thru, $\phi 11 \times 7.5$ dp	22	Rc1/8
50	148	64	32	32	130	M10×1.5	M10×1.5×22 dp	130	40	60	110	14	11	12	46	146	16	44	$\phi 8.6$ thru, $\phi 14 \times 9$ dp	24	Rc1/4
63	162	78	39	39	142	M10×1.5	M10×1.5×22 dp	130	50	70	124	16.5	13.5	16.5	58	158	16	49	$\phi 8.6$ thru, $\phi 14 \times 9$ dp	24	Rc1/4

Code Tube I.D.	PA	PB	Q1	S	VB	W	X	XA	XB	XC	XL	YY	N2					WB				
													25st	50,75,100st	101st~200st	201~300st	301~400st	25st	50,75,100st	101st~200st	201~300st	301~400st
40	13	18	16	10	72	38	50	4	4.5	3	6	M8×1.25×16 dp	24	48	124	200	300	34	46	84	122	172
50	9	21.5	20	12	92	47	66	5	6	4	8	M10×1.5×20 dp	24	48	124	200	300	36	48	86	124	174
63	14	28	20	12	110	55	80	5	6	4	8	M10×1.5×20 dp	28	52	128	—	—	38	50	88	—	—

## MCGS-03

Code Tube I.D.	L		L2			Q
	25,50st	51st~	25,50st	51~200st	201~400st	
40	97	102	31	36	63.5	$\phi 20$
50	106.5	118	34.5	46	78.5	$\phi 25$
63	106.5	118	29.5	41	—	$\phi 25$

## MCGS-23

Code Tube I.D.	L			L2				Q
	25,50st	75,100st	101st~	25,50st	75,100st	101~200st	201~400st	
40	81	98	118	15	32	52	72.5	$\phi 16$
50	93	114	134	21	42	62	87.5	$\phi 20$
63	93	114	134	16	37	57	—	$\phi 20$

# MCGS-07/27 Dimensions $\varnothing 12\sim\varnothing 20$

## TWIN-GUIDE CYLINDER

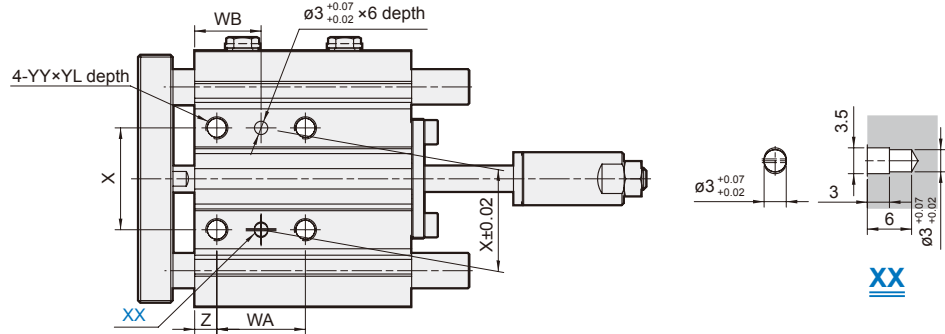

**Back side**

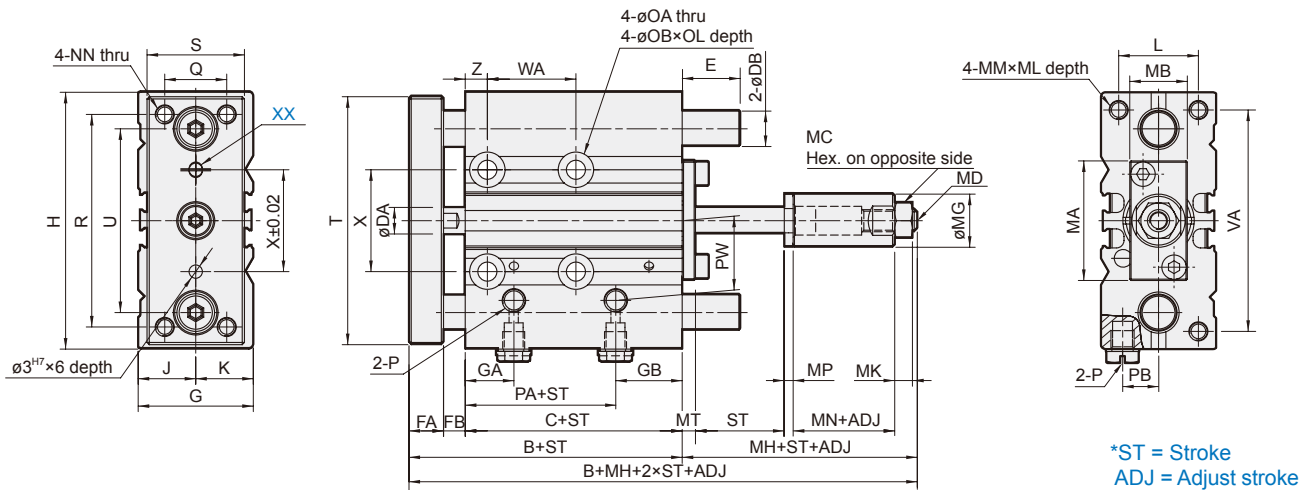

\*ST = Stroke  
ADJ = Adjust stroke

## MCGS-07 / MCGS-27

Code Tube I.D.	B	C	DA		DB		FA	FB	G	GA	GB	H	J	K	L	MA	MB	MC	MD	MG	MH	MK	MN	MM	ML	MP	MT
			07 type	27 type	07 type	27 type																					
12	42	29	6	8	6	8	5	26	11	15 <sup>(*1)</sup>	58	13	13	18	27	13	8	M5×0.8	12	23	4	13	M4×0.7	10	2	3	
16	46	33	8	10	8	8	5	30	11	18 <sup>(*2)</sup>	64	15	15	22	28	16	10	M6×1.0	15	26	5	15	M5×0.8	12	2	3	
20	53	37	10	12	10	10	6	36	10.5	8.5	85	17	19	24	33	22	13	M8×1.25	20	26	5	12	M5×0.8	13	3	4	

Code Tube I.D.	NN	OA	OB	OL	P	PA	PB	PW	Q	R	S	T	U	VA	X	YY	YL	Z
16	M5×0.8	4.3	8	4.5	M5×0.8	15	10.0	19	16	54	25	62	46	56	24	M5×0.8	10	5
20	M5×0.8	5.2	9.5	5.5	Rc1/8	12.5	11.5	25	18	70	30	81	55	72	28	M6×1.0	12	17

## MCGS-07

Code Tube I.D.	WA				WB					
	10~39st	40~100st	125~200st	201st~300st	10~39st	40~100st	125~200st	201~300st		
12	20	40	110	200	15	25	60	105		
16	~39st	40~100st	125~200st	201st~300st	~39st	40~100st	125~200st	201st~300st		
	24	44	110	200	17	27	60	105		
20	~39st	40~100st	125~200st	201st~300st	301st~	~39st	40~100st	125~200st	201st~300st	301st~
	24	44	120	200	300	29	39	77	117	167

Code Tube I.D.	E		
	~50st	51~100st	101st~
12	0	18.5	43
16	10~50st	51~100st	101st~
	0	18.5	49
20	~50st	51~200st	201st~
	0	31.5	69

## MCGS-27

Code Tube I.D.	E			
	~30st	31~100st	101st~	
12	1	13	43	
16	10~30st	31~100st	101st~	
	3	19	49	
20	20~30st	31~100st	101~200st	201st~
	10	27	51	69

\*1. When stroke length is equal to 19mm or less, GB=7.5 mm

\*2. When stroke length is equal to 19mm or less, GB=9 mm

# MCGS-07/27 Dimensions $\varnothing 25 \sim \varnothing 63$

## TWIN-GUIDE CYLINDER

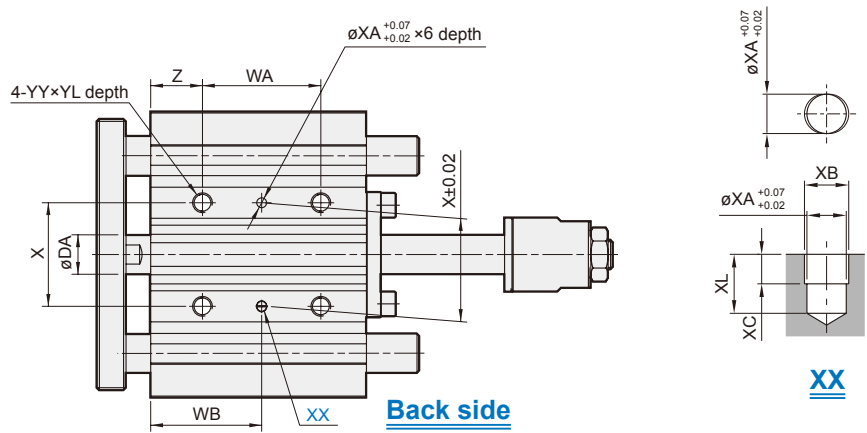

**Back side**

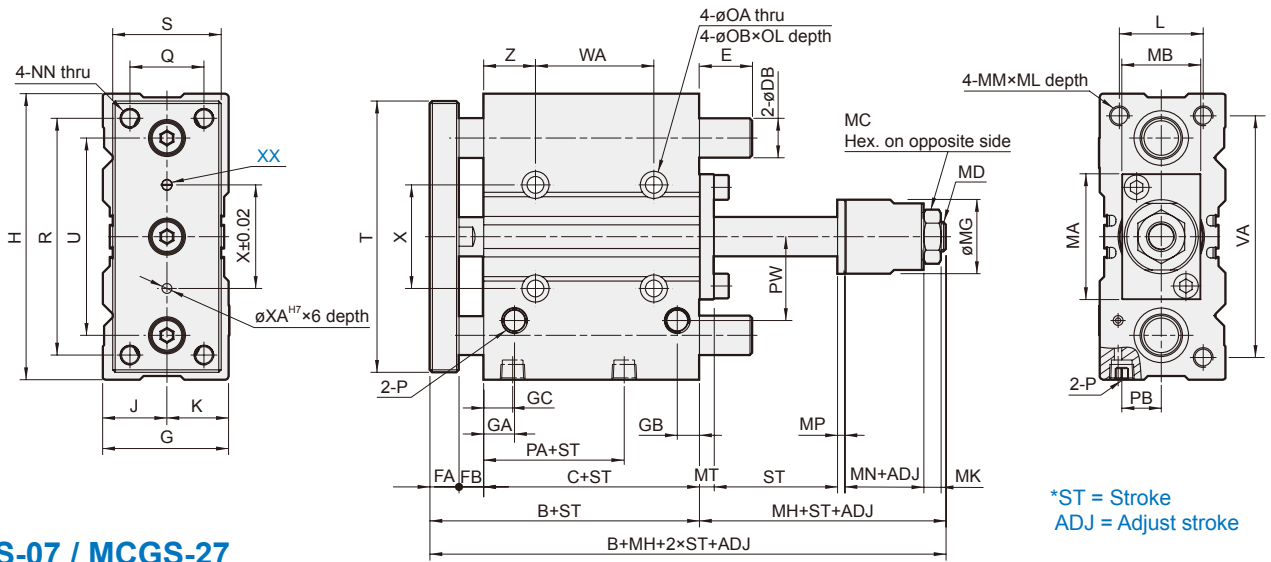

\*ST = Stroke  
ADJ = Adjust stroke

### MCGS-07 / MCGS-27

Code Tube I.D.	B	C	DA	DB		FA	FB	G	GA	GB	GC	H	J	K	L	MA	MB	MC	MD	MG	MH	MK	MN	MM	ML	MP	MT
				07 type	27 type																						
25	53.5	37.5	12	16	13	10	6	42	11.5	9	11.5	96	21	21	30	41	25	17	M10×1.25	20	27	6	12	M6×1.0	15	3	5
32	59.5	37.5	16	20	16	12	10	51	12.5	9	12.5	116	26	25	34	51	32	19	M12×1.25	30	30	7	12	M8×1.25	20	3	6
40	66	44	16	20	16	12	10	54	14	10	14	120	27	27	40	60	32	19	M12×1.25	30	30	7	12	M8×1.25	20	3	6
50	72	44	20	25	20	16	12	64	14	11	12	148	32	32	46	71	38	24	M16×1.5	35	38	8	15	M10×1.5	22	4	8
63	77	49	20	25	20	16	12	78	16.5	13.5	16.5	162	39	39	58	84	50	24	M16×1.5	35	38	8	15	M10×1.5	22	4	8

Code Tube I.D.	NN	OA	OB	OL	P	PA	PB	PW	Q	R	S	T	U	VA	X	XA	XB	XC	XL	YY	YL	Z
32	M8×1.25	6.6	11	7.5	Rc1/8	7	16	34	30	96	44	110	80	98	42	4	4.5	3	6	M8×1.25	16	21
40	M8×1.25	6.8	11	7.5	Rc1/8	13	18	38	30	104	44	118	86	106	50	4	4.5	3	6	M8×1.25	16	22
50	M10×1.5	8.6	14	9	Rc1/4	9	21.5	47	40	130	60	146	110	130	66	5	6	4	8	M10×1.5	20	24
63	M10×1.5	8.6	14	9	Rc1/4	14	28	55	50	130	70	158	124	142	80	5	6	4	8	M10×1.5	20	24

Code Tube I.D.	WA					WB						
	~39st	40~100st	125~200st	201st~300st	301st~	~39st	40~100st	125~200st	201st~300st	301st~		
25	24	44	120	200	300	29	39	77	117	167		
32	~49st	50~100st	125~200st	201st~300st	301st~	~49st	50~100st	125~200st	201st~300st	301st~		
	24	48	124	200	300	33	45	83	121	171		
40	~49st	50~69st	70~100st	125~200st	201st~300st	301st~	~49st	50~69st	70~100st	125~200st	201st~300st	301st~
	24	48	48	124	200	300	34	46	46	84	122	172
50	~49st	50~69st	70~100st	125~200st	201st~300st	301st~	~49st	50~69st	70~100st	125~200st	201st~300st	301st~
	24	48	48	124	200	300	36	48	48	86	124	174
63	~49st	50~100st	125st~				~49st	50~100st	125st~			
	28	52	128				38	50		88		

### MCGS-07

Code Tube I.D.	E		
	~50st	51~200st	201st~
25	0	31.5	68.5
32	37.5	42.5	80.5
40	31	36	63.5
50	34.5	46	78.5
63	~50st	51st~	
	29.5	41	

### MCGS-27

Code Tube I.D.	E			
	20~30st	31~100st	101~200st	201st~
25	16	32	51	68.5
32	20~50st	51~100st	101~200st	201st~
	21.5	38.5	58.5	80.5
40	~69st	70~100st	101~200st	201st~
	15	32	52	72.5
50	21	42	62	87.5
63	~69st	70~100st	101st~	
	16	37	57	