

### Order example

**MCGD — 03 — 12 — 50 — □**

MODEL                      TUBE I.D.    STROKE                      PORT THREAD

TYPE OF BEARING

Code	Type of bearing
03	Slide bush
23	Linear bearing

Blank: M5×0.8  
(for ø12,ø16)  
Blank: Rc thread  
G: G thread  
NPT: NPT thread  
(for ø20~ø32)

### Installation of sensor switch

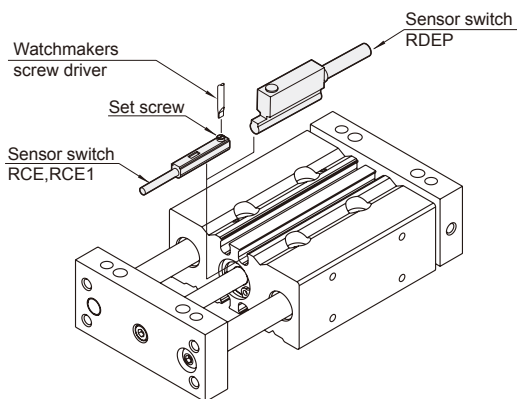

### Features

- Can be used as plate slide type or body slide type.
- The air cylinder and guide share a compact design which enables the cylinder to work smoothly along its stroke.
- The cylinder is extremely rigid and strong.
- Flush fitting sensor available.
- Magnetic as standard.

### Specification

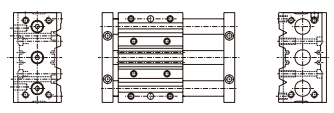
Model	MCGD	
Model (Stop type view)		
Acting type	Double acting	
Tube I.D.(mm)	12,16	20,25,32
Port size	M5×0.8	Rc1/8
Medium	Air	
Operating pressure range	0.1~1 MPa	
Proof pressure	1.5 MPa	
Ambient temperature	-5~+60°C (No freezing)	
Cushion	With rubber cushion pad	
Available speed range	50~500 mm/sec	
Lubrication	Not required	
Sensor switch (*)	RCE, RCE1, RDEP	

\* RCE, RCE1, RDEP specification, please refer to page 8-10, 14.

### Table for standard stroke

Series variety (Bearing type)	Tube I.D.	Stroke (mm)									
		30	50	75	100	125	150	175	200	250	300
MCGD-03 (Slide bush)	ø12										
	ø16										
	ø20										
	ø25										
	ø32										
MCGD-23 (Linear bearing)	ø12										
	ø16										
	ø20										
	ø25										
	ø32										

\* Stroke out of specification is also available.

\* Please consult us if stroke out of specification.

**MCGD-03**

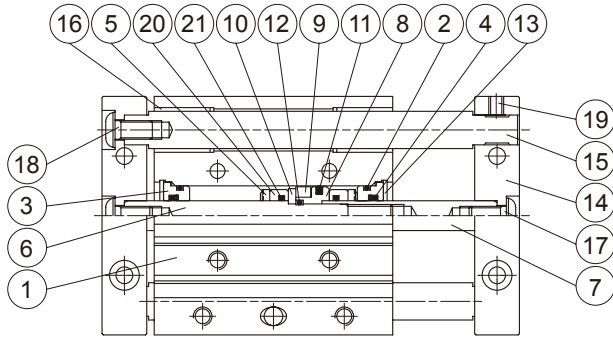

**MCGD-23**

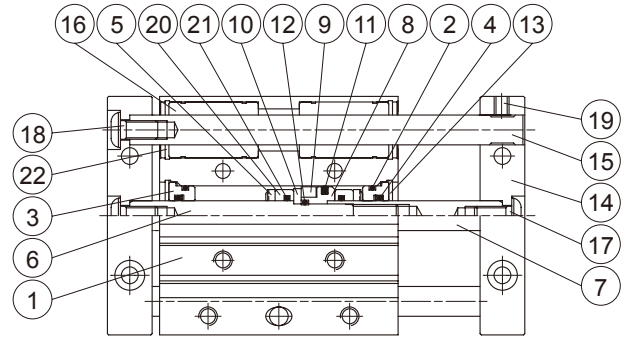

### Material

No.	Part name	Material	Note	Q'y	Repair kits (inclusion)
1	Body	Aluminum alloy		1	
2	Cover ring	NBR		2	●
3	Rod cover	Aluminum alloy		2	
4	Rod packing	NBR		2	●
5	Cushion	NBR		2	●
6	Piston rod #1	Carbon steel		1	
7	Piston rod #2	Carbon steel		1	
8	Piston	Aluminum alloy		1	
9	Magnet ring	Magnet material		1	
10	Magnet ring holder	Stainless steel		1	
11	Piston packing	NBR		1	●
12	Piston gasket	NBR		1	●
13	Snap ring	Spring steel		2	
14	Plate	Aluminum alloy		2	
15	Guide rod	Carbon steel	for <b>03</b> type	2	
		Special steel	for <b>23</b> type	2	
16	Slide bush	Bearing alloy	for <b>03</b> type	4	
	Linear bearing	—	for <b>23</b> type	4	
17	Bolt for piston rod	Carbon steel		2	
18	Bolt for guide rod	Carbon steel		4	
19	Set screw	Carbon steel		2	
20	Spacer	Aluminum alloy		2	
21	O-ring	NBR		2	
22	Snap ring	Spring steel	for <b>23</b> type	4	

### Order example of repair kits

Tube I.D.	Repair kits
ø12	<b>PS-MCGD-12</b>
ø16	<b>PS-MCGD-16</b>
ø20	<b>PS-MCGD-20</b>
ø25	<b>PS-MCGD-25</b>
ø32	<b>PS-MCGD-32</b>

TWIN-GUIDE SLIDE CYLINDER

MCGD-03/23

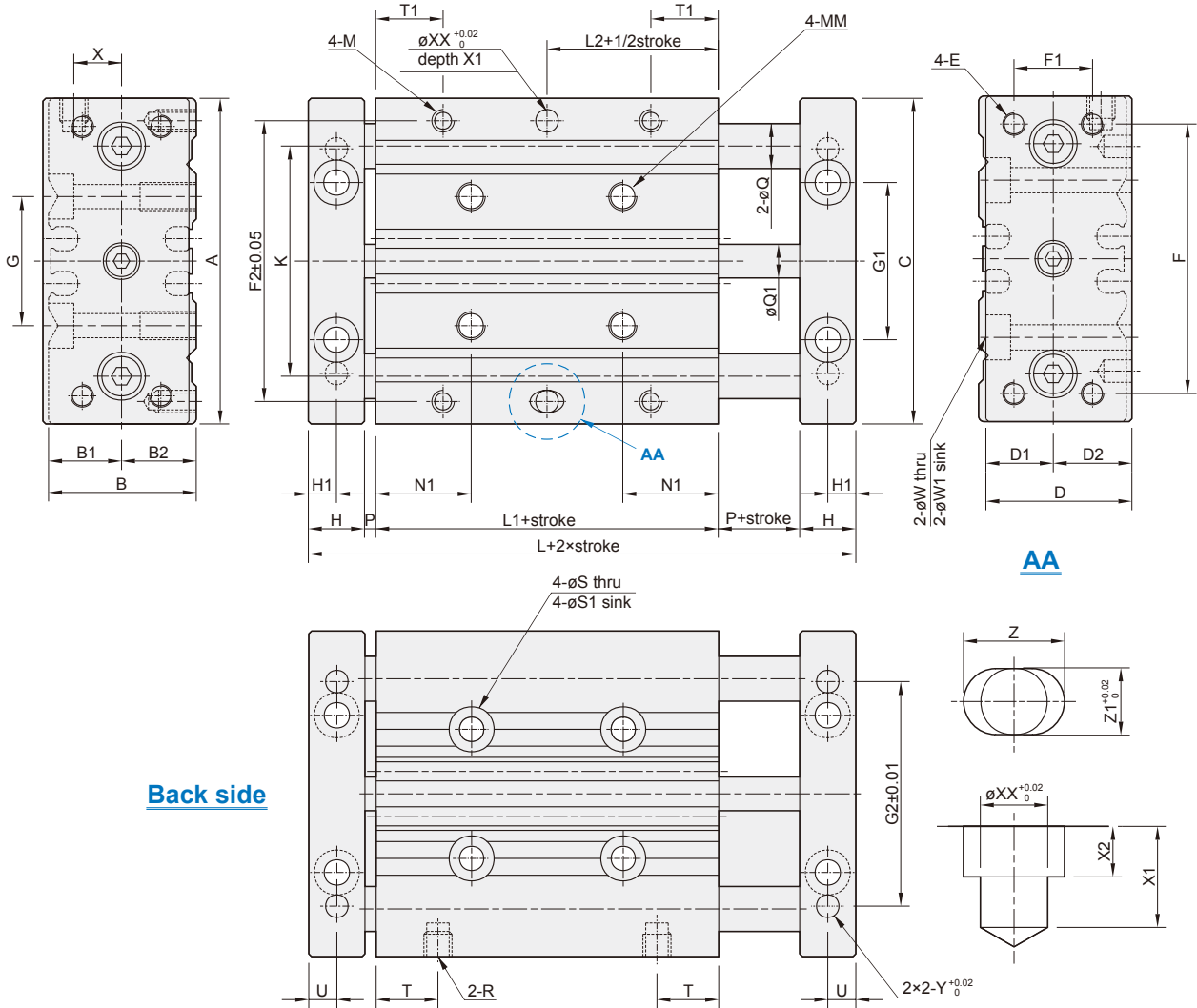

Back side

AA

Code Tube I.D.	A	B	B1	B2	C	D	D1	D2	E	F	F1	F2	G	G1	G2	H	H1	K	L	L1	L2	M	MM	N1	Q		Q1	P	R
																								MCGD-03	MCGD-23				
12	58	26	13	13	58	26	12	14	M4	48	14	50	23	28	40	10	5	41.5	55	31	15.5	M4×7dp	M5×10dp	17	$\varnothing 8$	$\varnothing 6$	$\varnothing 6$	2	M5
16	64	30	15	15	64	30	14	16	M5	52	16	54	24	32	50	12	6	46	62	34	17	M5×7dp	M5×10dp	17	$\varnothing 10$	$\varnothing 8$	$\varnothing 8$	2	M5
20	85	36	19	17	85	36	16	20	M5	60	18	64	28	37	70	12	6	55	66	38	19	M5×7dp	M6×12dp	20.5	$\varnothing 12$	$\varnothing 10$	$\varnothing 10$	2	Rc1/8
25	96	42	21	21	96	42	20	22	M6	70	26	76	34	44	84	12	6	65	67	39	19.5	M6×9dp	M6×12dp	19.5	$\varnothing 16$	$\varnothing 13$	$\varnothing 12$	2	Rc1/8
32	116	51	25	26	116	51	24	27	M8	96	30	100	42	56	76	14	7	80	68	36	18	M8×11dp	M8×16dp	20	$\varnothing 20$	$\varnothing 16$	$\varnothing 16$	2	Rc1/8

Code Tube I.D.	S	S1	T	T1	U	W	W1	X	XX	X1	X2	Y	Z	Z1
12	$\varnothing 4.3$	$\varnothing 8 \times 4.5dp$	11	12	5	$\varnothing 4.5$	$\varnothing 8 \times 4.5dp$	8.5	$\varnothing 4$	6	3	$\varnothing 4 \times 5dp$	6	4
16	$\varnothing 4.3$	$\varnothing 8 \times 4.5dp$	11	13	6	$\varnothing 4.5$	$\varnothing 8 \times 4.5dp$	10	$\varnothing 5$	6	3	$\varnothing 5 \times 5dp$	7	5
20	$\varnothing 5.2$	$\varnothing 9.5 \times 5.5dp$	13.5	14	6	$\varnothing 5.5$	$\varnothing 9.5 \times 5.5dp$	11.5	$\varnothing 6$	8	4	$\varnothing 6 \times 8dp$	8	6
25	$\varnothing 5.2$	$\varnothing 9.5 \times 5.5dp$	11	12	6	$\varnothing 5.5$	$\varnothing 9.5 \times 5.5dp$	13.5	$\varnothing 6$	8	4	$\varnothing 6 \times 8dp$	8	6
32	$\varnothing 6.8$	$\varnothing 11.5 \times 6.5dp$	11	16.5	7	$\varnothing 6.6$	$\varnothing 11 \times 6.5dp$	16	$\varnothing 8$	12	6	$\varnothing 8 \times 12dp$	10	8