

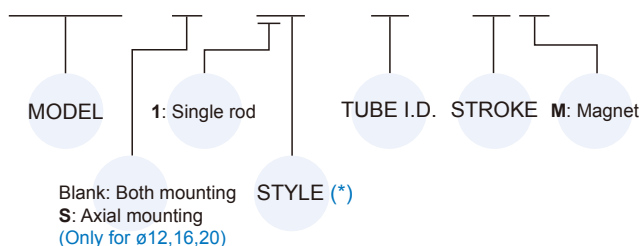



Order example

MCFB – S – 11 – 16 – 10M



* STYLE

Code	Symbol	Description
1 1		Double acting / Male thread
1 2		Double acting / Female thread
1 5		Single acting / Normally returned male thread
1 6		Single acting / Normally returned female thread

* Single acting only for $\phi 6, \phi 8, \phi 10$.

* Single acting without magnet type.

Features

- Compact and space saving.
- Flush fitting sensor.

Specification

Model	MCFB					
Acting type	Single / Double			Double acting		
Tube I.D. (mm)	6	8	10	12	16	20
Port size	M3×0.5					M5×0.8
Medium	Air					
Max. operating pressure	0.7 MPa					
Min. operating pressure (MPa)	Single	0.3	0.2	—		
	Double	0.15	0.1	0.07	0.05	
Proof pressure	1 MPa					
Lubrication	Not required					
Ambient temperature	-5~+60°C (No freezing)					
Available speed range	50~500 mm/sec					
Sensor switch (*)	RDF, RDFV, RDGV					

* Short stroke length (4, 6, 8mm) only use RDGV.

* RDF, RDGV specification, please refer to page 8-15, 16.

Double acting – Table for standard stroke

Tube I.D.	Stroke (mm)
$\phi 6, 8$	4, 6, 8, 10, 15, 20, 25
$\phi 10$	4, 6, 8, 10, 15, 20, 30
$\phi 12, 16$	5, 10, 15, 20, 25, 30
$\phi 20$	5, 10, 15, 20, 25, 30, 35, 40, 45, 50

Single acting – Table for standard stroke

Tube I.D.	Stroke (mm)
$\phi 6$	4, 6, 8
$\phi 8, 10$	4, 6, 8, 10

Installation of sensor switch

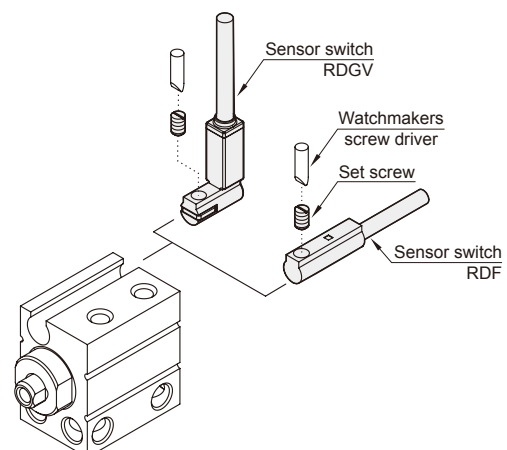

ø6, ø8, ø10

Double acting

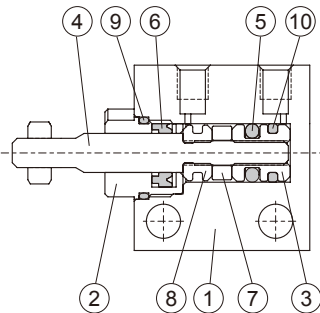

Single acting

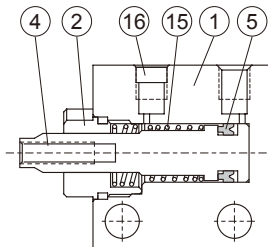

ø12, ø16, ø20

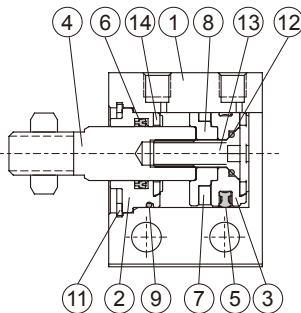

Material

No.	Part name	Material	Note
1	Body	Aluminum alloy	
2	Rod cover	Copper	ø12~20 use aluminum alloy
3	Piston	Aluminum alloy	
4	Piston rod	Stainless steel	
5	Piston packing	NBR	
6	Rod packing	NBR	
7	Magnet ring	Magnet material	for with magnet
8	Piston	Aluminum alloy	for with magnet
9	O-ring	NBR	
10	Wear ring	Teflon	
11	Snap ring	Stainless steel	
12	O-ring	NBR	Only for ø20
13	Piston bolt	Stainless steel	Only for ø20
14	Cushion packing	PU	
15	Spring	Stainless steel	
16	Silencer	Brass	

Cylinder weight

Unit: g

11: Male thread (With magnet)								11: Male thread (Without magnet)							
Stroke (mm)	ø6	ø8	ø10	Stroke (mm)	ø12	ø16	ø20	Stroke (mm)	ø6	ø8	ø10	Stroke (mm)	ø12	ø16	ø20
4	16	20	23	5	27	42	68	4	15	19	21	5	24	38	63
6	17	21	24	10	32	49	78	6	16	20	22	10	29	45	73
8	18	23	26	15	37	56	88	8	18	22	24	15	34	52	83
10	19	24	27	20	42	63	98	10	19	23	25	20	39	59	93
15	22	27	31	25	47	70	108	15	22	26	29	25	44	66	103
20	25	31	34	30	52	77	118	20	25	29	32	30	49	73	113
25	28	34	38	40	—	—	138	25	28	33	36	40	—	—	133
30	—	—	41	50	—	—	158	30	—	—	39	50	—	—	153

12: Male thread (With magnet)								12: Male thread (Without magnet)							
Stroke (mm)	ø6	ø8	ø10	Stroke (mm)	ø12	ø16	ø20	Stroke (mm)	ø6	ø8	ø10	Stroke (mm)	ø12	ø16	ø20
4	15	18	20	5	24	35	57	4	14	17	18	5	21	31	52
6	16	19	21	10	29	42	67	6	15	18	19	10	26	38	62
8	17	20	23	15	34	49	77	8	16	19	21	15	31	45	72
10	18	22	24	20	39	56	87	10	18	21	22	20	36	52	82
15	21	25	28	25	44	63	97	15	21	24	26	25	41	59	92
20	24	28	31	30	49	70	107	20	24	27	29	30	46	66	102
25	27	31	35	40	—	—	127	25	27	30	33	40	—	—	122
30	—	—	38	50	—	—	147	30	—	—	36	50	—	—	142

MULTI-MOUNT CYLINDER

Mindman

$\phi 6, \phi 8, \phi 10$

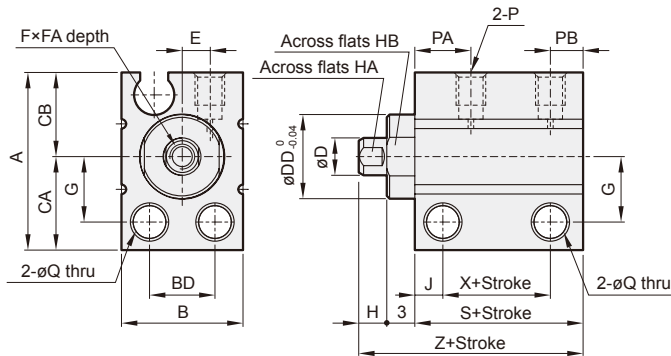

$\phi 12, \phi 16, \phi 20$

Both mounting

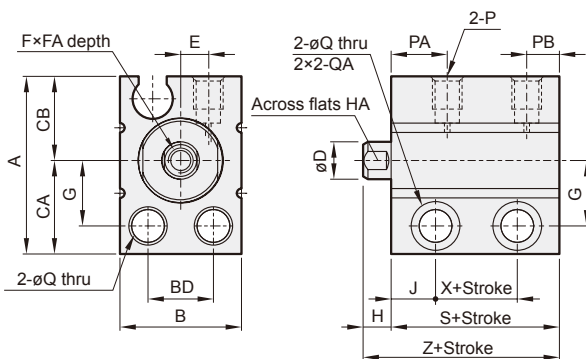

Axial mounting

MCFB-S

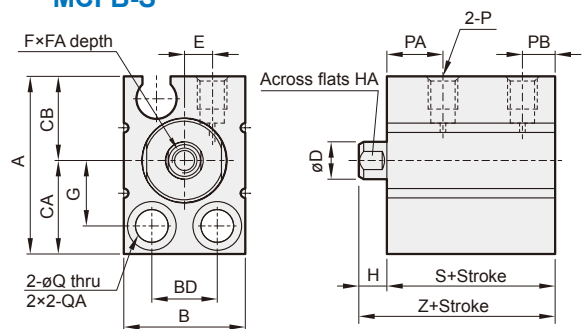

$\phi 6, \phi 8, \phi 10$

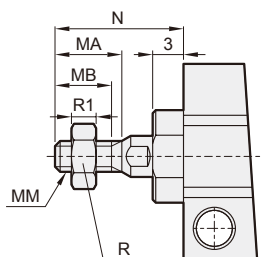

$\phi 12, \phi 16, \phi 20$

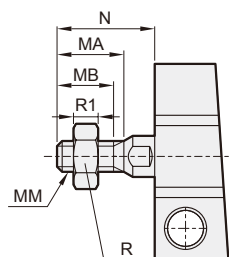

MCFB-11/15 male thread size

Code Tube I.D.	MA	MB	MM	N	R	R1
6	6.5	5.5	M3×0.5	12.5	5.5	2.4
8	8.5	7	M4×0.7	14.5	7	3.2
10	10.5	9	M5×0.8	16.5	8	4
12	10.5	9	M5×0.8	14	8	4
16	12	10	M6×1.0	15.5	10	5
20	14	12	M8×1.25	18.5	13	5

Code Tube I.D.	A	B	BD	CA	CB	D	DD	E	F	FA	G	H	HA	HB	J	P	PA	PB	Q	QA	Without magnet			Magnet		
	X	S	Z	X	S	Z																				
6	19	13	7	10	9	4	9	3	M2.5×0.45	5	7	3	3.5	8	3	M3×0.5	6	3.5	3.5	—	6.5	13	19	11.5	18	24
8	21	13	7	11	10	5	11	3	M3×0.5	6	8	3	4.5	10	3	M3×0.5	6	3.5	3.5	—	6.5	13	19	11.5	18	24
10	22	13.5	7	11.5	10.5	6	12	3.2	M3×0.5	6	8.5	3	5	11	3	M3×0.5	6	3.5	3.5	—	6.5	13	19	11.5	18	24
12	26.5	17	8	15.5	11	6	—	3.5	M3×0.5	6	11	3.5	5	—	6	M3×0.5	7.5	4	4.4	∅7.5, 7dp	3.5	15.5	19	7.5	19.5	23
16	29.5	21	11.5	17	12.5	8	—	5.5	M4×0.7	8	12.5	3.5	6	—	6	M3×0.5	8.5	4	4.4	∅7.5, 7dp	4	16.5	20	8.5	21	24.5
20	36	25	13.5	21	15	10	—	7	M5×0.8	7	15.5	4.5	8	—	7	M5×0.8	9	5.5	5.5	∅9.5, 9dp	5.5	19.5	24	9.5	23.5	28