

Features

- Compact in width and length with precision guidance.
- High lateral loads can be applied on both slide and linear bearing unit.
- Magnetic as standard.

Specification

Model	MCDJ	
Acting type	Double acting	
Tube I.D.(mm)	6	10
Port size	M3×0.5	M5×0.8
Medium	Air	
Operating pressure range	Max.	0.7 MPa
	Min.	0.15 MPa 0.1 MPa
Proof pressure	1 MPa	
Ambient temperature	-5~+60°C (No freezing)	
Cushion	With rubber cushion pad (both side)	
Available speed range	50~500 mm/sec	
Lubrication	Not required (If lubrication is used, apply turbine oil NO1 ISO VG32)	
Sensor switch (*)	RDF, RDGV	

* RDF, RDGV, specification, please refer to page 8-15, 16.

Table for standard stroke

Tube I.D.	Stroke (mm)	Max. stroke
ø6	10,20,30,40,50	50
ø10	10,20,30,40,50	50

- Stroke out of specification is also available.
- Please consult us if stroke out of specification.
- It is possible to adjust length of basic stroke by 0~5 mm.

Order example

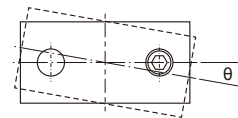
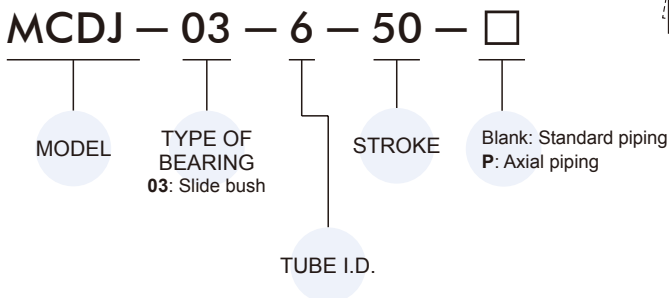

Tube I.D.	ø6, ø10
MCDJ-03	±0.1°

Installation of sensor switch

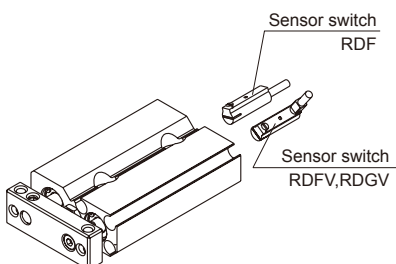

Top mounting

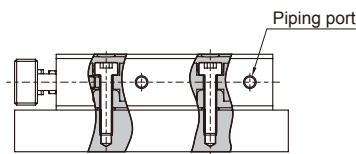

Bottom mounting

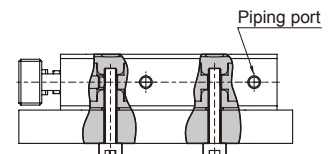

Side mounting

* Only for "P": axial piping".

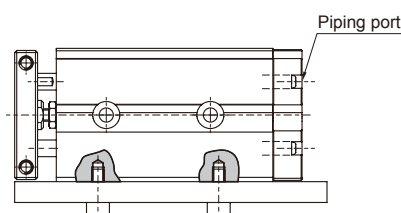

Work can be mounted on three faces of the rod square plate.

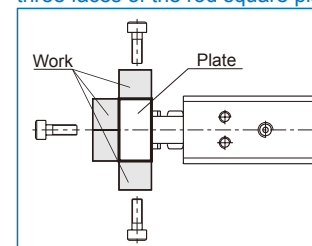

MCDJ-03 Inside structure & Parts list

DUAL-ROD CYLINDER



Standrad piping

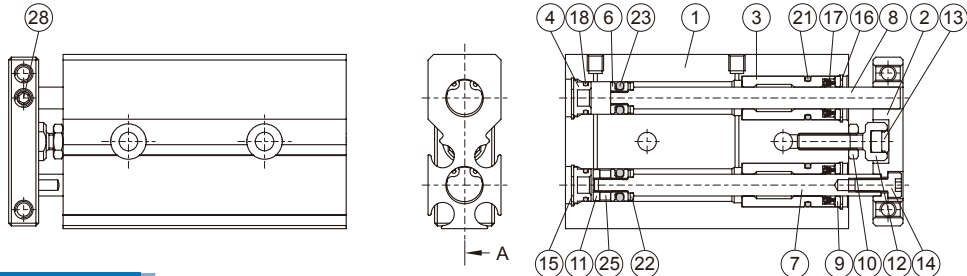

Axial piping

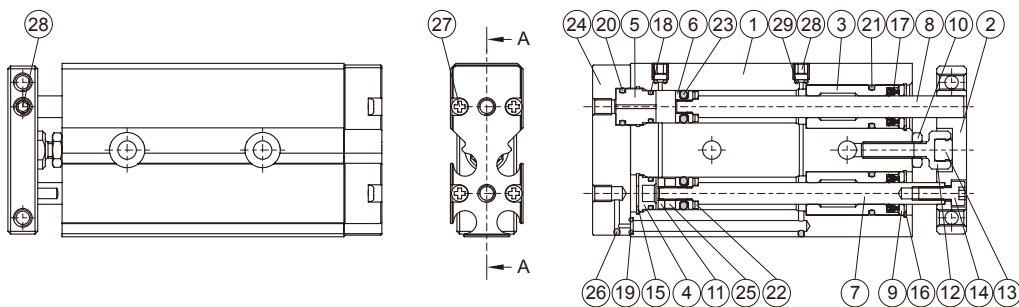

Material

No.	Tube I.D. Part name	6	10	Standard piping		Axial piping	
				Q'y	Repair kits (inclusion)	Q'y	Repair kits (inclusion)
1	Body	Aluminum alloy		1		1	
2	Plate	Aluminum alloy		1		1	
3	Rod cover	Aluminum alloy		2		2	
4	End cover	Aluminum alloy		2		1	
5	End cover (Axial)	Aluminum alloy		-		1	
6	Piston	Stainless steel		2		2	
7	Piston rod #1	Stainless steel		1		1	
8	Piston rod #2	Stainless steel		1		1	
9	Rod cover washer	SUS	—	2		2	
10	Nut	Carbon steel		1		1	
11	Piston	Aluminum alloy		1		1	
12	Cushion screw	Stainless steel		1		1	
13	Bumper	PU		1		1	
14	Screw	Stainless steel		1		1	
15	Snap ring	Spring steel		2		1	
16	Snap ring	Spring steel		2		2	
17	Rod packing	NBR		2	●	2	●
18	O-ring	NBR		2	●	2	●
19	O-ring	NBR		-		1	●
20	O-ring	NBR		-		1	●
21	O-ring	NBR		2	●	2	●
22	Rod cushion	NBR		2	●	2	●
23	Piston packing	NBR		2	●	2	●
24	Port cover	Aluminum alloy		-		1	
25	Magnet ring	Magnet material		1		1	
26	Steel ball	Stainless steel		-		2	
27	Screw	Iron		-		4	
28	Bolt	Stainless steel		1		3	
29	O-ring	NBR		-		2	●

Order example of repair kits

Piping type	Tube I.D.	Repair kits
Standard	ø6	PS-MCDJ-6
	ø10	PS-MCDJ-10
Axial	ø6	PS-MCDJ-6-P
	ø10	PS-MCDJ-10-P
Lubricant (10g)		GR-A-010

Cylinder weight

Unit: g

Piping type	Standard piping		Axial piping	
	ø6	ø10	ø6	ø10
Tube I.D.				
Stroke				
10	45	97	51	109
20	54	111	61	124
30	64	125	71	137
40	74	139	80	152
50	84	154	90	166
75	—	188	—	201

DUAL-ROD CYLINDER

Standrad piping

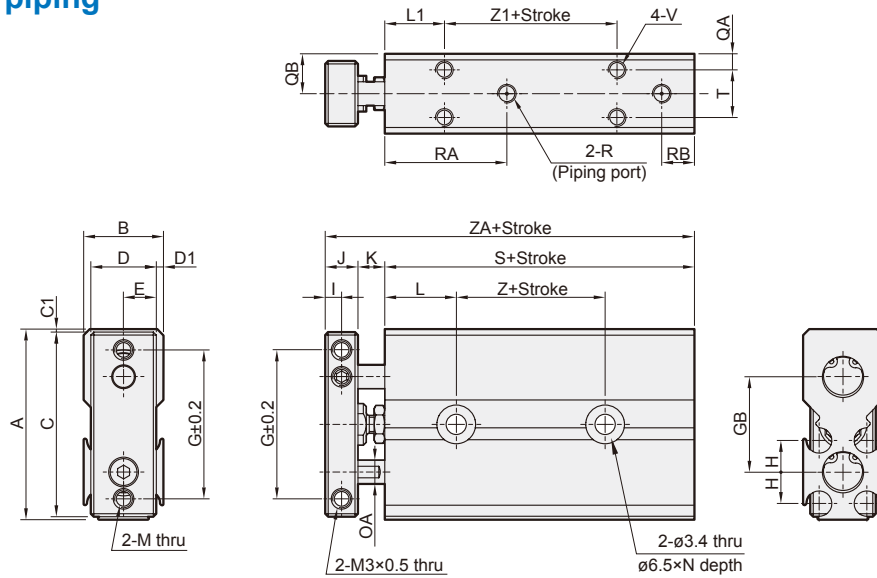

Axial piping

P

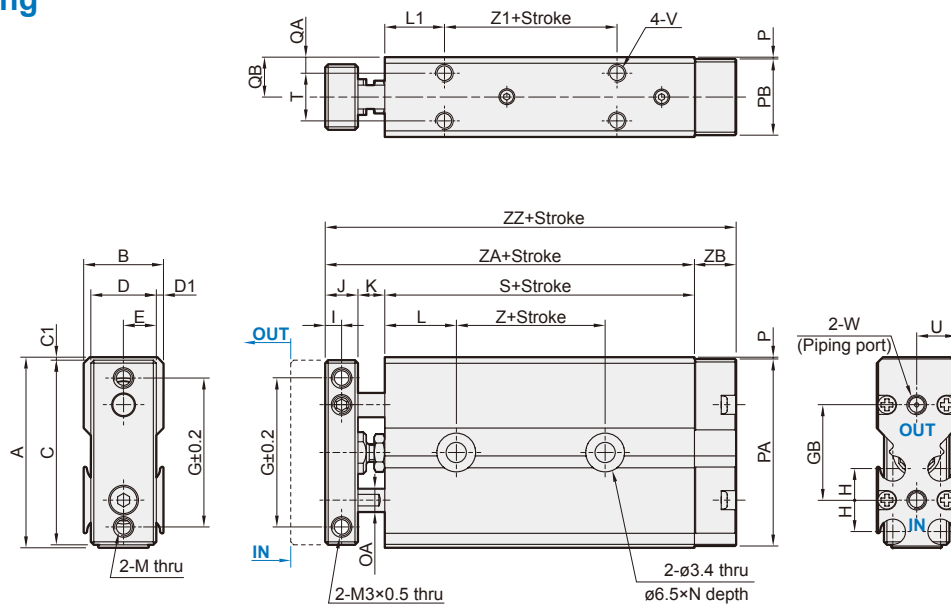

Code Tube I.D.	A	B	C	C1	D	D1	E	G	GB	H	I	J	K	L	L1	M	N	OA	P	PA	PB	QA	QB	R	RA	RB
6	32	13.4	31	0.5	11	1.2	5.5	25	16	5.3	2.75	5.5	4.5	12	10	M3×0.5	5	$\varnothing 4$	0.3	31.4	12.8	2.7	6.7	M3×0.5×3 dp	20.5	5.5
10	42	15	40	1	13	1	6.5	33	20	8	4	8	3.5	16	16	M4×0.7	5.5	$\varnothing 6$	0.3	41.4	14.4	3.5	7.5	M5×0.8×4 dp	28.5	8

Code Tube I.D.	S	T	U	V	W	Z	Z1	ZA	ZB	ZZ
6	32	8	6.7	M3×0.5×3.5 dp	M3×0.5×3 dp	5	9	42	7	49
10	44.5	8	7.5	M3×0.5×4.5 dp	M5×0.8×4 dp	8	12	56	8.5	64.5