

- Start-up valve for low speed air supply to gradually raise initial pressure in an air system and for quick exhaust by cutting off air supply.
- Combination with modular type air units (F.R.L. unit).

### Specification

Model	MAVS200	MAVS300	MAVS400
Bore No.	8A	10A	15A
Port size	1/4	3/8	1/2
Medium	Air		
Operating pressure range (*)	0.25~1 MPa		
Effective orifice	1(P)→2(A)	20 mm <sup>2</sup>	37 mm <sup>2</sup>
	2(A)→3(R)	24 mm <sup>2</sup>	49 mm <sup>2</sup>
Ambient temperature	0~+60°C		
Voltage	AC110V, 220V (50/60)Hz, DC24V		
Power consumption	AC=4.8/4.4VA, 6/4.9VA DC=2W		
Available voltage range	±10%		
Insulation class	F class		
Option	Pressure gauge (PG-40), L type bracket		
Weight	450 g	520 g	800 g

### Order example

MAVS400 - 15A - 1 - □ - B - AC110 - L - □

MODEL

200  
300  
400

PORT SIZE

8A: 1/4 (for 200 type)  
10A: 3/8 (for 300 type)  
15A: 1/2 (for 400 type)

BRACKET

Blank: Without  
B: L type bracket

VOLTAGE

AC220V(50/60)Hz  
AC110V(50/60)Hz  
DC24V

PORT THREAD

Blank: Rc thread  
G: G thread  
NPT: NPT thread

PRESSURE GAUGE

Blank: Without  
C: With pressure gauge (PG-40)

Blank: DIN connector  
L: DIN connect with LED indicator  
E: Explosion protection (Table 1)

(E type use black coil)

### Symbol

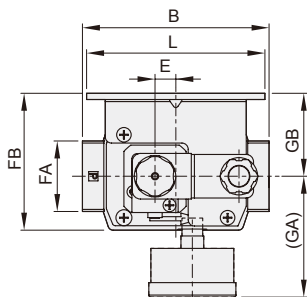
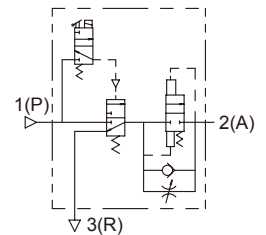

EXTERIOR COLOR (\*)

1: Silver (for air unit 401 series)  
3: Cool gray (for air unit 401-W, 403 series)

\*MAVS200/300 only have cool gray, if selected MAVS200/300 type can skip this option.

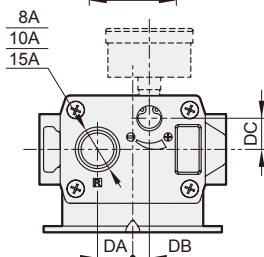
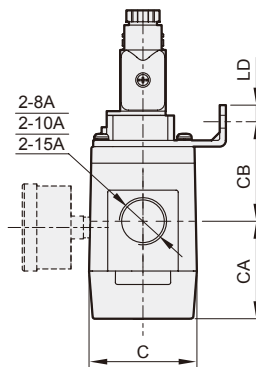
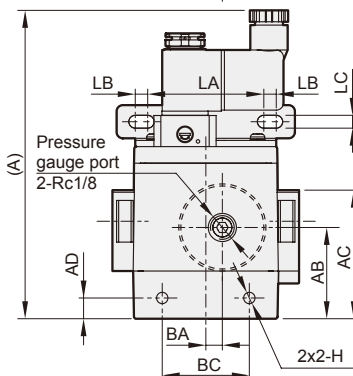

Table 1

### Property for explosion-proof type

Anti-explosion class	EEx m II T4
Voltage	AC110V, 220V, (50/60)Hz, DC24V.
Power consumption	AC=4.4VA DC=5W
Available voltage range	±10%
Insulation class	F class
Wire length	3 m

### Piping note

When the air current is restricted or insufficient pressure, the main valve will not function / switch normally and it could cause air to leak from the R port.  
The total effective orifice of the piping material and component on the P port side:

MAVS200	Total effective orifice ≥5mm <sup>2</sup>
MAVS300	Total effective orifice ≥22mm <sup>2</sup>
MAVS400	Total effective orifice ≥35mm <sup>2</sup>

### Dimensions

Code Model	A	AB	AC	AD	B	BA	BC	C	CA	CB	DA	DB	DC
200	126.6	31	41.2	7.5	66	5	29	39.6	31.2	40.2	11	5	11
300	134	34	50.5	8.5	78	5	28	47.6	36	31.9	14	5	14
400	149	44	62	10	90	8	42	52	47	48	17	8	15

Code Model	E	FA	FB	GA	GB	H	L	LA	LB	LC	LD
200	8.9	35	47.3	53.8	27.5	M4×0.7×4.5 depth	68	50	3.5	4.3	7
300	11	29	56.3	55	32.5	M5×0.8×5 depth	76	55	5	5.2	8
400	10	34	66	60	40	M6×1.0×6 depth	86	56	6	6.2	8

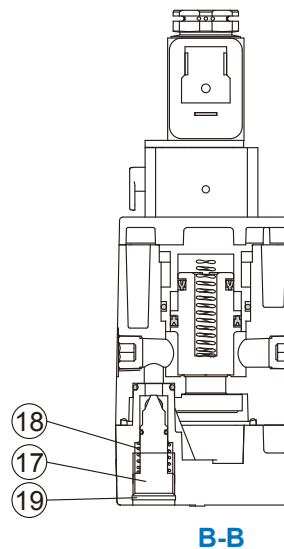
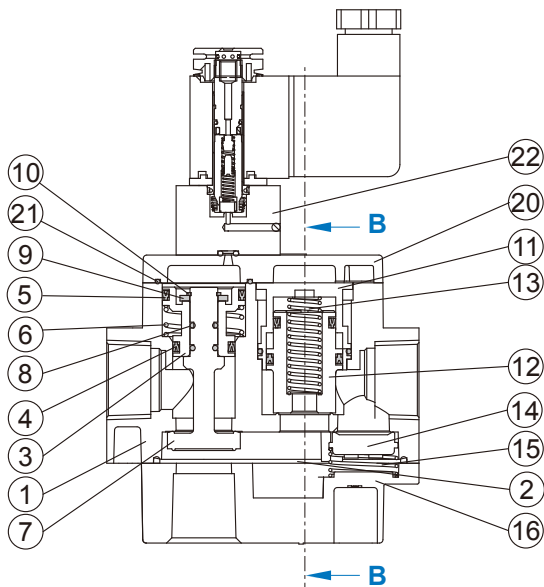

### Material

No.	Part name	Material
1	Body	Aluminum alloy
2	Body packing	NBR
3	Piston A	Aluminum alloy
4	Seal ring	NBR
5	Rod packing	NBR
6	Piston A spring	SWP
7	Main valve assembly	Copper+NBR
8	O-ring	NBR
9	Washer	SPC
10	Snap ring	Spring steel
11	Piston guide assembly	Aluminum alloy
12	Piston B	Copper+NBR
13	Piston B spring	Stainless steel
14	Check valve	Copper+NBR
15	Check valve spring	Stainless steel
16	Cap	Aluminum alloy
17	Needle valve	Copper
18	Needle valve spring	SWP
19	Snap ring	Spring steel
20	Cover	Aluminum alloy
21	Cover ring	NBR
22	Pilot valve assembly	-

### Flow feature

Piston B switching pressure (Close→Open)

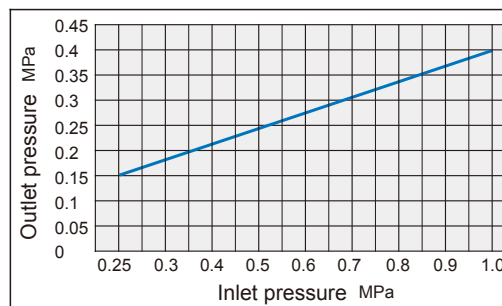

Needle valve flow characteristics

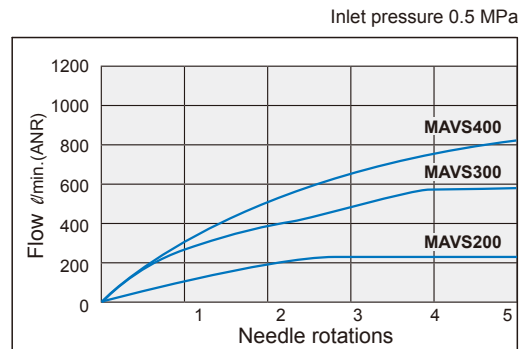

### Combination with air units (F.R.L. unit)

Air unit (F.R.L.)		Valve
MA**302		MAVS300
MA**401	MA**403	MAVS400

EX: MACT403+MAVS400

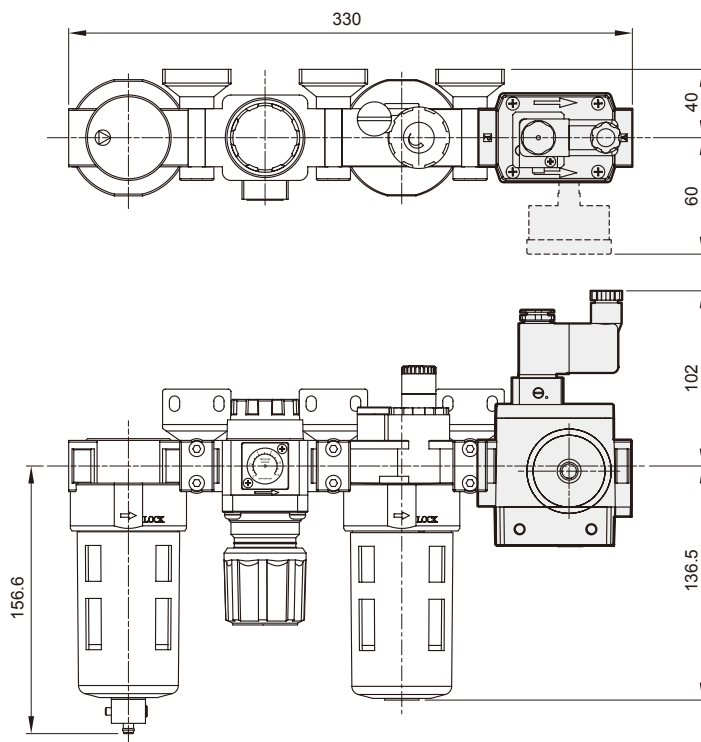

### Bracket / Joiner set

BT: T type bracket/ BL: L type bracket/ BS: Joiner set

Order example	BT-MACP302	BS-MACP302
Pictures		
Applicable model	MACP302, MACT302	MACP302, MACT302

Order example	BL-MACP401	BL-MACP403	BS-MACP401	BS-MACP403
Pictures				
Applicable model	MACP401, MACT401	MACP401-W, MACT401-W MACP403, MACT403	MACP401, MACT401	MACP401-W, MACT401-W MACP403, MACT403