

MAFR402 series

AIR UNIT (F.R.UNIT)

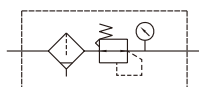

Symbol



Specification

Model	MAFR402		
Bore No.	10A	15A	20A
Port size	3/8	1/2	3/4
Medium	Air		
Operating pressure range (*)	0.05~1 MPa		
Proof pressure	1.5 MPa		
Regulated pressure range	0.05~0.85 MPa		
Ambient temperature	- 5~+60°C (No freezing)		
Filter element	Standard: 40μm Option: 5,20μm		
Attachment	Pressure gauge, bracket		
Weight	1186 g		

* Standard unit contains semi-auto-drain function when operating pressure below 0.05 MPa.

Order example

MAFR402 - 15A - D - □ - □

MODEL

PORT SIZE

10A: 3/8
15A: 1/2
20A: 3/4

FILTER ELEMENT

Blank: 40μm
5u: 5μm
20u: 20μm

PORT THREAD

Blank: Rc thread
G: G thread
NPT: NPT thread

Blank: Semi-auto drain

D: Auto drain valve (YD401)

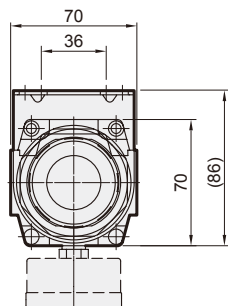

Panel mounting hole

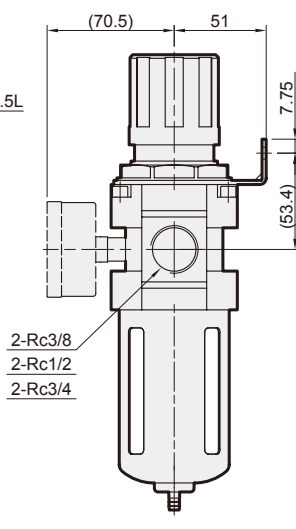
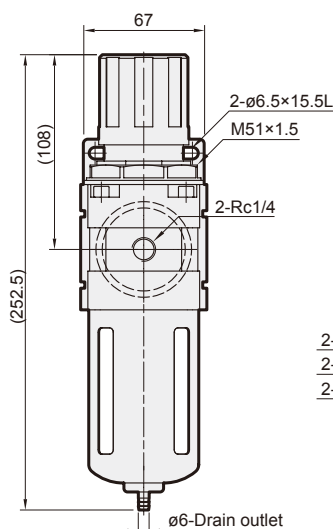
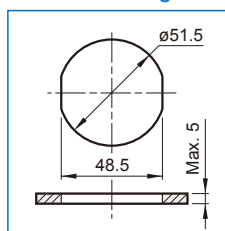

Flow feature

10A, 15A, 20A

Primary pressure
0.7 MPa

