

MAFR300 series

AIR UNIT (F.R.UNIT)

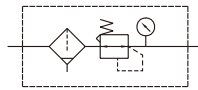

Symbol



Specification

Model	MAFR300	
Bore No.	8A	10A
Port size	1/4	3/8
Medium	Air	
Operating pressure range (*)	0.05~1 MPa	
Proof pressure	1.5 MPa	
Regulated pressure range	0.05~0.85 MPa	
Ambient temperature	- 5~+60°C (No freezing)	
Filter element	Standard: 5µm, Option: 40 µm	
Drain capacity	30 cm ³	
Attachment	Pressure gauge (PG-40), L-type bracket	
Weight	445g	

* Standard unit contains semi-auto-drain function when operating pressure below 0.05 MPa.

Order example

MAFR300 - 8A - □ - □ - □ - □

MODEL

PORT SIZE

8A: 1/4
10A: 3/8

Blank: PC bowl
N: Nylon bowl

FILTER ELEMENT

Blank: 5µm
40u: 40µm

BRACKET

Blank: L type
B3: Z type

PORT THREAD

Blank: Rc thread
G: G thread
NPT: NPT thread

Panel mounting hole

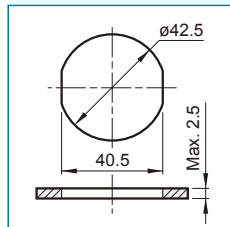

Z type bracket

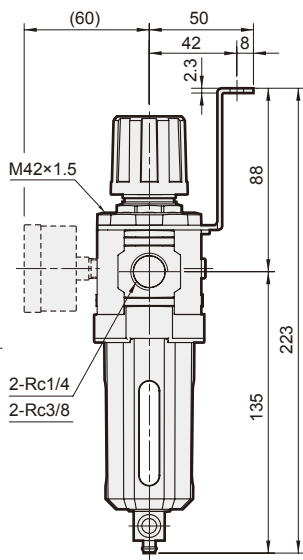

Flow feature

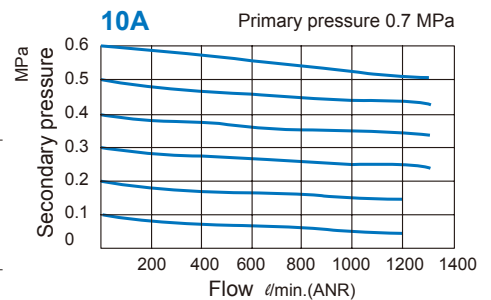
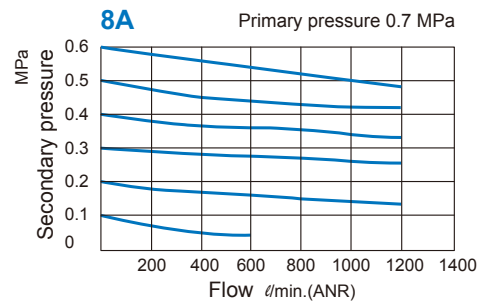

L type bracket

