

MAF901 series

AIR UNIT (FILITER)



mindman



Symbol

Manual drain

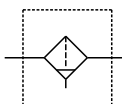

Auto drain

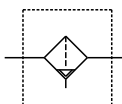

- MAF901 with high water removal efficiency and minimal pressure drop are used for removal of liquids and solid contaminants to protect air tools and equipment.
- Ideally suited for header lines and very high flow applications.

Specification

Model	MAF901
Bore No.	50A
Port size	2
Medium	Air
Operating pressure range (*1)	0.05~1.75MPa
Ambient temperature	0~+80°C (No freezing)
Filter element	Standard:50μm
Standard nominal flow rate (*2)	63000 ℓ /min
Weight	6930 g

*1. Choose auto-drain, the pressure range is 0.15 ~ 1.75 MPa.

*2. Flow is at pressure P= 0.6 MPa with pressure drop ΔP=0.1 MPa.

Order example

MAF901 – 50A – D – □

MODEL

BORE SIZE
50A: 2

PORT THREAD
Blank: Rc thread
G: G thread
NPT: NPT thread

Blank: Manual drain
D: Auto drain

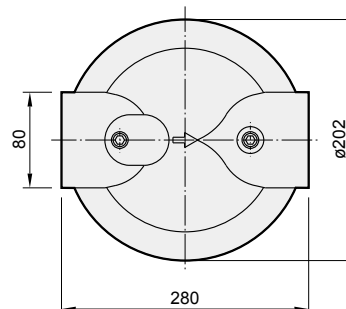

Flow feature

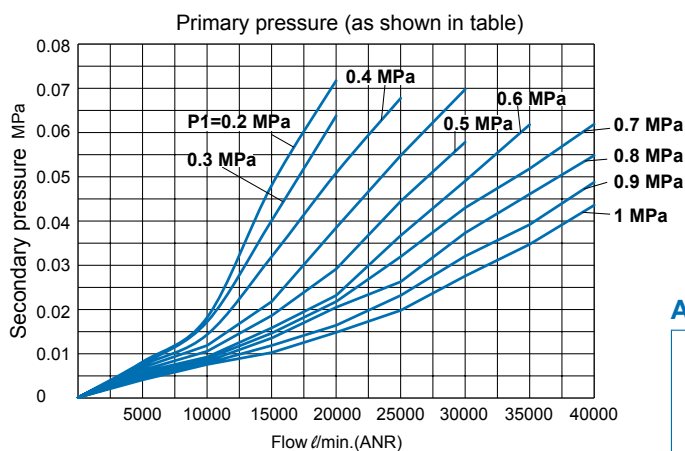

Auto drain

