

MAF900 series

AIR UNIT (FILITER)



Symbol

Manual drain

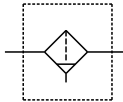

Auto drain

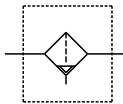

- Removing upto 99% of the liquid water.
- Design of the filter elements gives both surface and depth filtration for cleaner air.
- Ideally suited for header lines and large flow rated tools and cylinder operations.

Specification

Model	MAF900
Bore No.	40A
Port size	1 1/2
Medium	Air
Operating perssure range (*1)	0.05~1.75MPa
Ambient temperature	0~+80°C (No freezing)
Filter element	Standard: 50μm
Standard nominal flow rate (*2)	20000 ℓ /min
Weight	2035 g

*1. Choose auto-drain, the pressure range is 0.15 ~ 1.75 MPa.
 *2. Flow is at pressure P= 0.6 MPa with pressure drop ΔP=0.1 MPa.

Order example

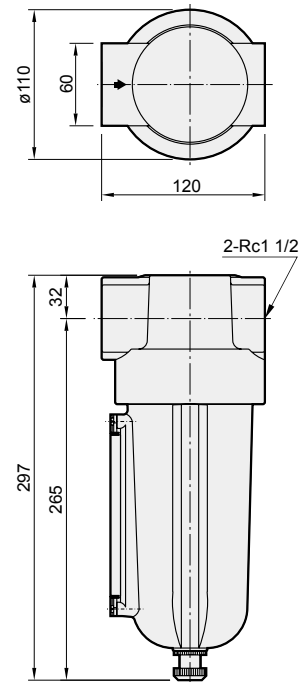
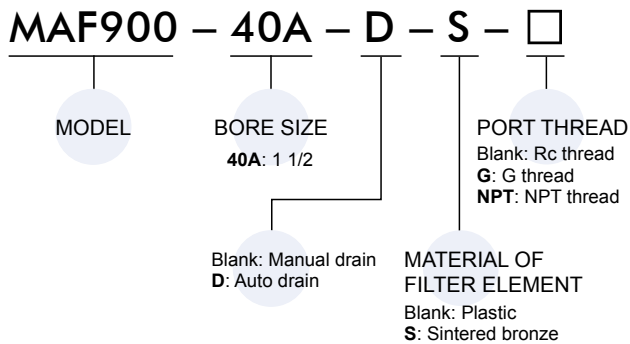

Flow feature

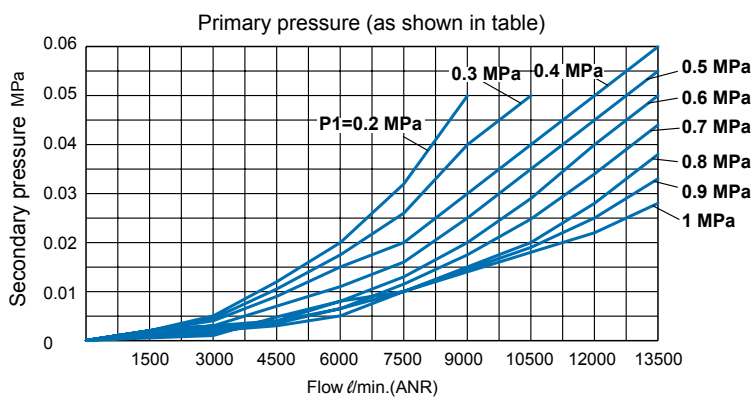

Auto drain

