

MACP302 series

AIR UNIT (F.R.L.UNIT)



Option: **MP41**

Symbol

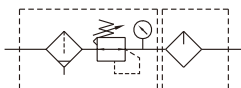

Specification

Model	MACP302		
Components	MAFR302, MAL302		
Bore No.	8A	10A	15A
Port size	1/4	3/8	1/2
Medium	Air		
Operating pressure range (*)	0.05~1 MPa		
Proof pressure	1.5 MPa		
Regulated pressure range	0.05~0.85 MPa		
Ambient temperature	- 5~+60°C (No freezing)		
Filter element	Standard: 5µm, Option: 40µm		
Lubricating oil capacity	65c.c		
Min. flow for oil drip	50 l/min	60 l/min	
Recommended lubricating oil	Turbine oil ISO-VG32		
Attachment	Pressure gauge(PG-20),T-type bracket		
Weight	845 g		

* Standard unit contains semi-auto-drain function when operating pressure below 0.05 MPa.

* Choose auto-drain FMRF300, the pressure range is 0.15~1 MPa.

Order example

MACP302 – 8A – DN – E1 – □ – T8 – □

MODEL

PORT SIZE

8A: 1/4
10A: 3/8
15A: 1/2

FILTER ELEMENT
Blank: 5µm
40u: 40µm

PORT THREAD
Blank: Rc thread
G: G thread
NPT: NPT thread

Blank: PC bowl + Semi-auto drain
C: External pressure gauge (PG-40)
D: Auto drain valve (FMRF300)
N: Nylon bowl

(Option)

PRESSURE SWITCH

E1: MP41P-022
E2: MP41P-022-QD
E5: MP41P-042
E6: MP41P-042-QD

(Option)

BY-PASS PORT SIZE

T type bracket	T8: 1/4 T10: 3/8 T15: 1/2
Check valve	K8: 1/4 K10: 3/8

* PG-40 (C) and MP41 (E*) can not be selected at the same time.

* Be sure to use above check valves when redirecting the air flow on the inlet side of the lubricator.

* Refer to page 5-11 for the option of digital pressure switch MP41 (E*).

Flow feature

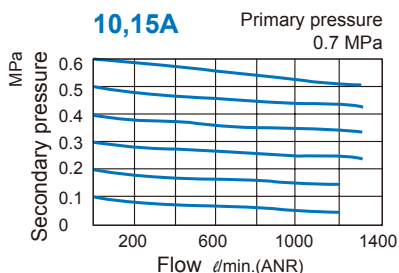
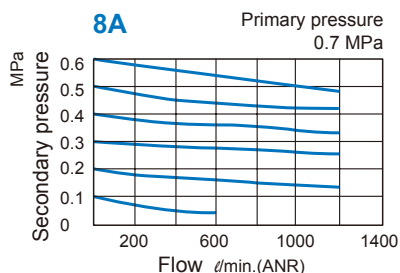

MACP302 Dimensions

AIR UNIT (F.R.L.UNIT)

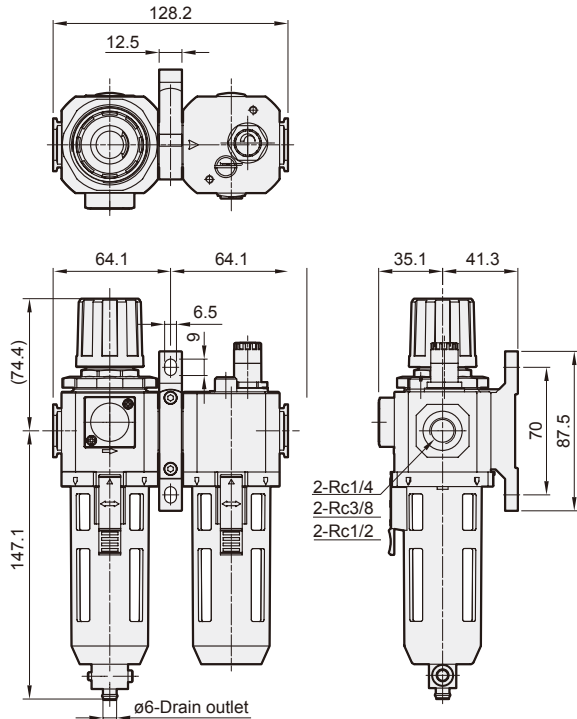

MACP302-D*

Auto drain valve

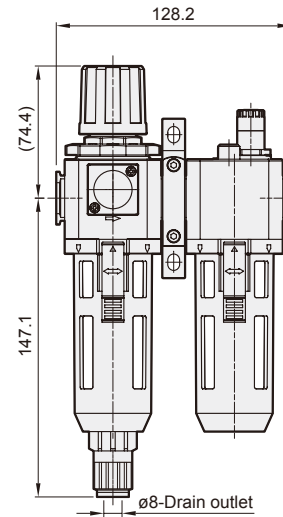

MACP302-K*

Check valve

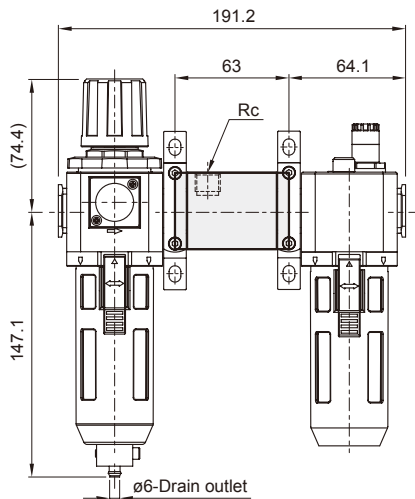

MACP302-T*

T type bracket

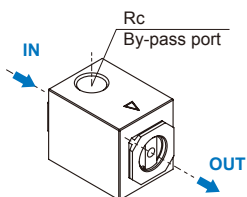
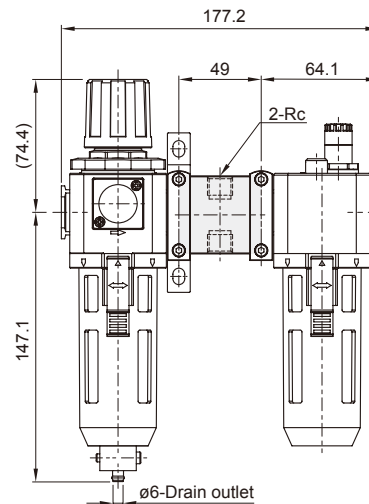

Port	Rc
Check valve	
K8	Rc1/4
K10	Rc3/8

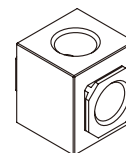

Port	Rc
Bracket	
T8	Rc1/4
T10	Rc3/8
T15	Rc1/2

* Threads for IN and OUT ports are not machined.

MACP302-HT With shutoff valve

AIR UNIT (F.R.L.UNIT)



Order example

MACP302 – 8A – □ – E1 – □ – HT – □

MODEL

PORT SIZE

8A: 1/4
10A: 3/8
15A: 1/2

FILTER
ELEMENT

Blank: 5µm
40u: 40µm

PORT THREAD

Blank: Rc thread
G: G thread
NPT: NPT thread

(Option)

PRESSURE SWITCH

E1: MP41P-022
E2: MP41P-022-QD
E5: MP41P-042
E6: MP41P-042-QD

SHUTOFF VALVE

HT: MVHT-302-3H

Blank: Standard type

(PC bowl + Semi-auto drain)

C: External pressure gauge (PG-40)

D: Auto drain valve (FMRF300)

N: Nylon bowl

* PG-40 (C) and MP41 (E*) can not be selected at the same time.

* Refer to page 5-11 for the option of digital pressure switch MP41 (E*).

