

MACC300 series

AIR UNIT (F.R.L.UNIT)

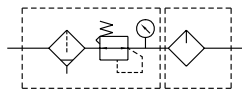

Symbol



Order example

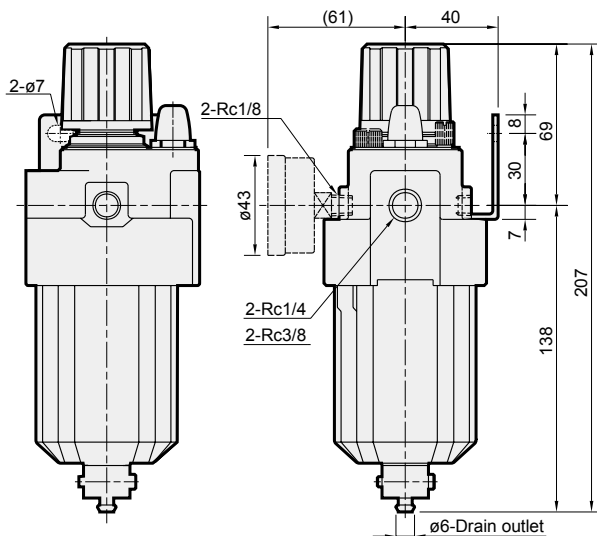
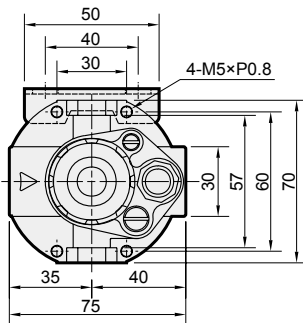
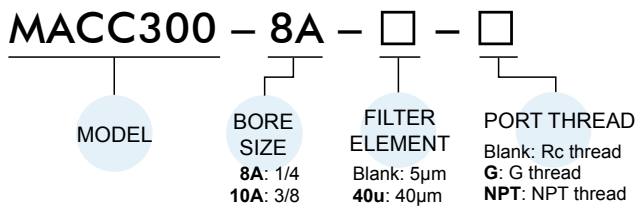

Specification

Model	MACC300	
Bore No.	8A	10A
Port size	1/4	3/8
Medium	Air	
Operating pressure range (*)	0.05~1 MPa	
Proof pressure	1.5 MPa	
Effective orifice	28mm ²	30mm ²
Regulated pressure range	0.05~0.85 MPa	
Ambient temperature	- 5~+60°C (No freezing)	
Filter element	Standard: 5μm Option: 40μm	
Lubricating oil capacity	50c.c	
Min. flow for oil drip	50 ℓ/min	60 ℓ/min
Recommended lubricating oil	Turbine oil ISO-VG32	
Attachment	Pressure gauge(PG-40), L-type bracket	
Weight	660 g	

* Standard unit contains semi-auto-drain function when operating pressure below 0.05 MPa.

Flow feature

