

Series 16, 24 and 25 mini-cylinders



Series 16: \varnothing 8, 10, 12 mm

Series 24: \varnothing 16, 20, 25 mm - magnetic

Series 25: 16, 20, 25 mm - magnetic, cushioned



- » Single-acting and double-acting
- » Standard CETOP RP52P DIN/ISO 6432
- » Stainless steel rod and barrel
- » Anodized aluminium end-blocks

Series 16, 24 and 25 mini-cylinders are designed according to the European Standard Specifications CETOP RP52-P and DIN/ISO 6432. The choice of materials and other design features have provided the basis for a complete range of versatile and very reliable cylinders.

The precise method of crimping the barrel at the head and cap ensures that all the parts are perfectly aligned. Since the Series 16 and 24 may operate at very high speeds, bumpers are attached to the piston as standard in order to reduce noise and wear resulting from high impact loads. Series 24 and 25 are suitable for mounting magnetic proximity switches. Series 25 has an adjustable pneumatic cushion and a magnetic piston. Various mounting accessories are available to enable the cylinders to function in a variety of applications.

GENERAL DATA

Type of construction	crimped
Operation	single-acting and double-acting
Materials	anodized aluminium end-caps - stainless steel barrel and rod, aluminium piston - NBR/PU seals, other parts: see the coding example
Brackets	rod end - flange - feet - trunnion
Stroke min - max	Series 16 \varnothing 8 + \varnothing 10: 10 - 250 mm / Series 16: \varnothing 12: 10 - 300 mm / Series 24 & 25 \varnothing 16: 10 - 600 mm; \varnothing 20 - \varnothing 25: 10 - 1000 mm
Bores	Series 16: \varnothing 8, 10, 12 / Series 24 & 25: \varnothing 16, 20, 25
Operating temperature	0°C + 80°C (with dry air -20°C)
Operating pressure	1 + 10 bar (double-acting); 2 + 10 bar (single-acting)
Fluid	filtered air, without lubrication. If lubricated air is used, it is recommended to use oil ISO VG32. Once applied the lubrication should never be interrupted.
Speed	10 + 1000 mm/sec (without load)

STANDARD STROKES FOR MINICYLINDERS SERIES 16 - 24 and 25

■ = Double-acting
 ✕ = Single-acting

STANDARD STROKES															
Series	Ø	10	25	40	50	80	100	125	160	200	250	300	320	400	500
16	8	✕	✕	✕	✕	■	■	■	■	■					
16	10	✕	✕	✕	✕	■	■	■	■	■					
16	12	✕	✕	✕	✕	■	■	■	■	■	■				
24	16	✕	✕	✕	✕	■	■	■	■	■	■	■			
24	20	✕	✕	✕	✕	■	■	■	■	■	■	■	■	■	■
24	25	✕	✕	✕	✕	■	■	■	■	■	■	■	■	■	■
25	16	■	■	■	■	■	■	■	■	■	■	■	■	■	■
25	20	■	■	■	■	■	■	■	■	■	■	■	■	■	■
25	25	■	■	■	■	■	■	■	■	■	■	■	■	■	■

CODING EXAMPLE

24	N	2	A	16	A	100	
24	SERIES 16 = non magnetic 24 = magnetic 25 = magnetic, adjustable cushioning				PNEUMATIC SYMBOLS CS02 (s. 16) - CS06 (s. 24) CD01 (s. 16) - CD07 (s. 24) - CD09 (s. 25) CD05 (s. 16) - CD12 (s. 24) - CD13 (s. 25) CS04 (s. 16) - CS10 (s. 24)		
N	VERSION N = standard						
2	OPERATION 1 = single-acting, front spring, no cushion 2 = double-acting 3 = double-acting, through-rod 7 = single-acting, through-rod						
A	MATERIALS A = rolled stainless steel AISI 303 rod, stainless steel AISI 304 tube, anodized AL end-blocks						
16	BORE 08 = 8 mm - 10 = 10 mm - 12 = 12 mm - 16 = 16 mm - 20 = 20 mm - 25 = 25 mm						
A	CONSTRUCTION A = Nose nut Mod. V + Piston rod lock nut Mod. U RL = cylinder with rod lock ø20 - ø25						
100	STROKE (see the table)						
	= standard V = rod seal in FKM W = all seals in FKM, +130°C (for series 25 only)						

PNEUMATIC SYMBOLS

The pneumatic symbols which have been indicated in the CODING EXAMPLE are shown below.

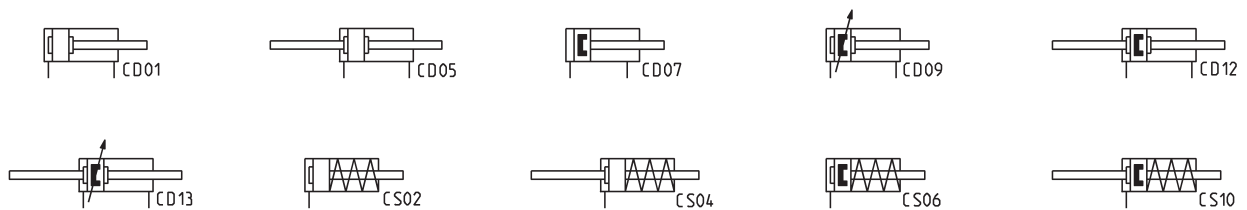

ACCESSORIES FOR MINICYLINDERS SERIES 16 - 24 - 25

Foot mount Mod. B



Front/rear flange mount Mod. E



Rear trunnion bracket Mod. I



Rod fork end Mod. G



Swivel ball joint Mod. GA



Piston rod socket joint Mod. GY



Piston rod lock nut Mod. U



Nose nut Mod. V



Self aligning rod Mod. GK



Coupling piece Mod. GKF



All accessories are supplied separately, except for piston rod lock nut Mod. U and nose nut Mod. V

Minicylinders Series 16, 24 and 25

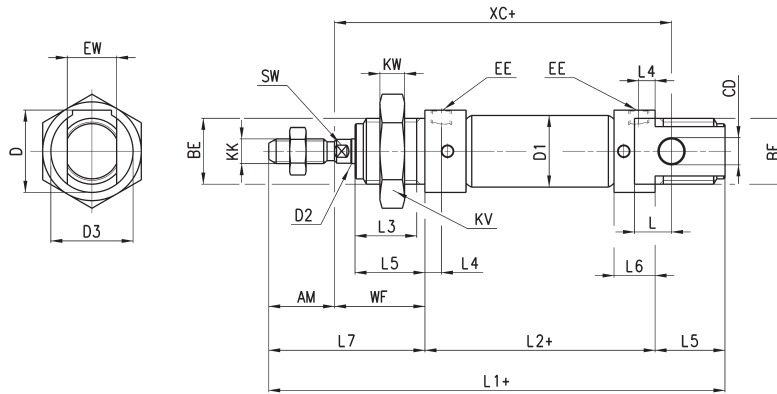

+ = add the stroke

DIMENSIONS

Series	∅	EW	KW	BE	KK	CD	D1	EE	∅D2	L1+	XC+	L2+	AM	L3	L4	L5	L	WF	L6	L7	KV	SW	D	D3	front/rear cushion stroke
16	8	8	7	M12x1,25	M4x0,7	4	9,3	M5	4	86	64	46	12	10	4,5	12	6	16	9	28	19	-	15	15	- / -
16	10	8	7	M12x1,25	M4x0,7	4	11,3	M5	4	86	64	46	12	10	4,5	12	6	16	9	28	19	-	15	15	- / -
16	12	12	8	M16x1,5	M6x1	6	13,3	M5	6	105	75	50	16	15	4,5	17	9	22	9	38	24	5	20,5	20	- / -
24-25	16	12	8	M16x1,5	M6x1	6	17,3	M5	6	111	82	56	16	15	5,5	17	9	22	10	38	24	5	20,5	20	10 / 10
24-25	20	16	10	M22x1,5	M8x1,25	8	21,3	G1/8	8	132	95	68	20	18	8	20	12	24	16	44	32	7	27	27	13 / 15
24-25	25	16	10	M22x1,5	M10x1,25	8	26,5	G1/8	10	141,5	104	69,5	22	20	8	22	12	28	16	50	32	9	27	27	16 / 14

Minicylinders Series 16, 24 and 25 - through-rod

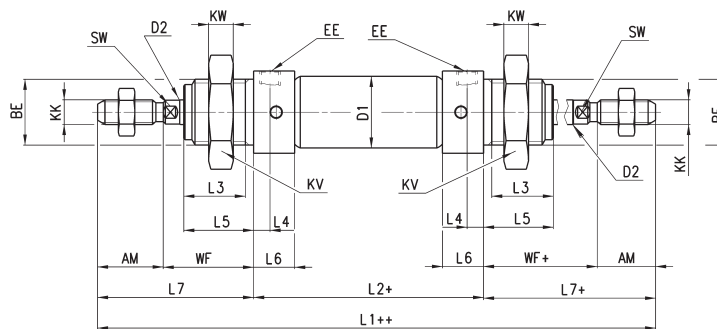

+ = add the stroke once
++ = add the stroke twice

DIMENSIONS

Series	∅	KW	BE	KK	∅D1	EE	∅D2	L1++	L2+	AM	L3	L4	L5	WF+	L6	L7+	KV	SW	front/rear cushion stroke
16	8	7	M12x1,25	M4x0,7	9,3	M5	4	102	46	12	10	4,5	12	16	9	28	19	-	- / -
16	10	7	M12x1,25	M4x0,7	11,3	M5	4	102	46	12	10	4,5	12	16	9	28	19	-	- / -
16	12	8	M16x1,5	M6x1	13,3	M5	6	126	50	16	15	4,5	17	22	9	38	24	5	- / -
24-25	16	8	M16x1,5	M6x1	17,3	M5	6	132	56	16	15	5,5	17	22	10	38	24	5	10 / 10
24-25	20	10	M22x1,5	M8x1,25	21,3	G1/8	8	156	68	20	18	8	20	24	16	44	32	7	13 / 15
24-25	25	10	M22x1,5	M10x1,25	26,5	G1/8	10	169,5	69,5	22	20	8	22	28	16	50	32	9	16 / 14

Series 24 and 25 minicylinders with rod lock (Mod. RLC)



+ = add the stroke

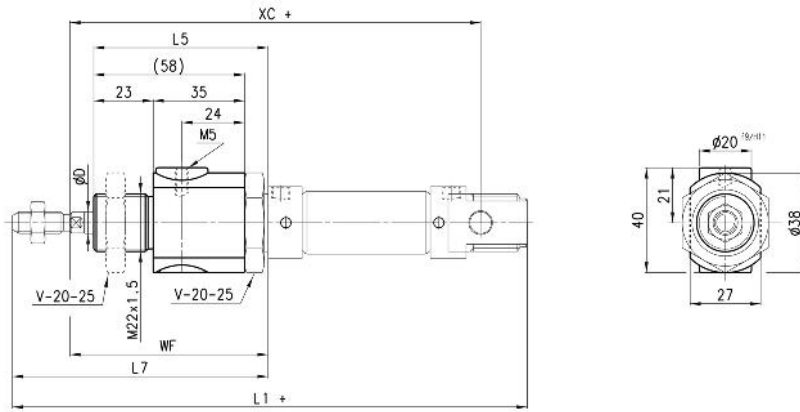

DIMENSIONS

Series	Ø	^{G7} D	WF	L5	L7	XC+	L1+	F (N)
24-25	20	8	74	70	94	145	182	300
24-25	25	10	76	70	98	152	189,5	400

Foot mount Mod. B

Feet and nose nut material: zinc-plated steel.



Supplied with:
2x feet
1x nose nut mod. V

+ = add the stroke

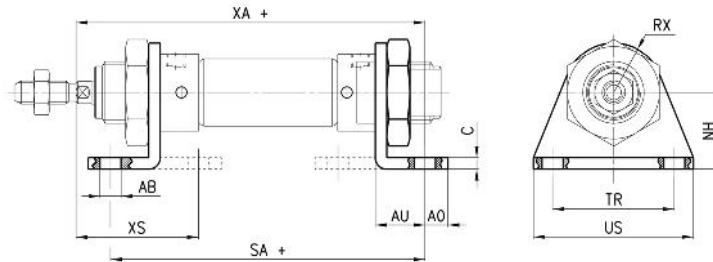

DIMENSIONS

Mod.	∅	∅AB	XS	XA+	SA+	AO	AU	C	RX	TR	US	NH
B-8-10	8-10	4,5	54	72,5	67	4,5	10,5	2,5	10	25	35	16
B-12-16	12	5,5	64	82,5	71	6	13	3	13	32	42	20
B-12-16	16	5,5	68	91	82	6	13	3	13	32	42	20
B-20-25	20	6,6	80	108	100	8	16	4	20	40	54	25
B-20-25	25	6,6	85,5	113,5	101,5	8	16	4	20	40	54	25

Front/rear flange mount Mod. E

Material: zinc-plated steel.



+ = add the stroke

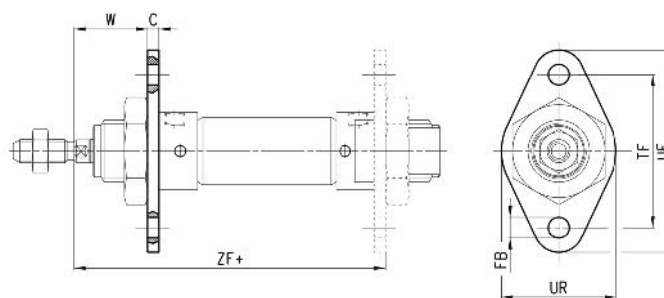

DIMENSIONS

Mod.	∅	W	C	ZF+	FB	UR	TF	UF
E-8-10	8-10	13,5	2,5	64,5	4,5	40	30	25
E-12-16	12	19	3	75	5,5	53	40	30
E-12-16	16	19	3	81	5,5	53	40	30
E-20-25	20	20	4	96	6,6	66	50	40
E-20-25	25	24	4	101,5	6,6	66	50	40

Rear trunnion bracket Mod. I

Supplied with:
 1x zinc-plated steel rear trunnion
 1x stainless steel clevis pin
 2x steel Seeger

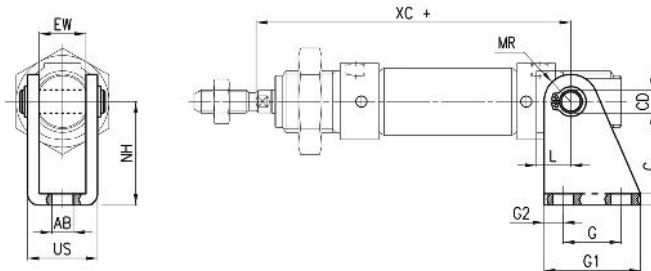

+ = add the stroke

DIMENSIONS

Mod.	Ø	EW	ØAB	US	NH	XC+	MR	L	G2	G	G1	CD	C
I-8-10	8-10	8	4,5	13,1	24	64	5	6	3,5	12,5	20	4	2,5
I-12-16	12	12	5,5	18,1	27	75	7	9	5	15	25	6	3
I-12-16	16	12	5,5	18,1	27	82	7	9	5	15	25	6	3
I-20-25	20	16	6,6	24,1	30	95	10	12	6	20	32	8	4
I-20-25	25	16	6,6	24,1	30	104	10	12	6	20	32	8	4

Rod fork end Mod. G

ISO 8140
 Material: zinc-plated steel.

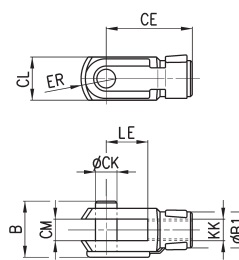

DIMENSIONS

Mod.	Ø	CL	ER	CE	B	CM	ØCK	LE	KK	ØB1
G-8-10	8-10	8	5	16	11	4	4	8	M4x0,7	8
G-12-16	12-16	12	7	24	16	6	6	12	M6x1	10
G-20	20	16	10	32	22	8	8	16	M8x1,25	14
G-25-32	25	20	12	40	26	10	10	20	M10x1,25	18

Swivel ball joint Mod. GA

ISO 8139
 Material: zinc-plated steel.

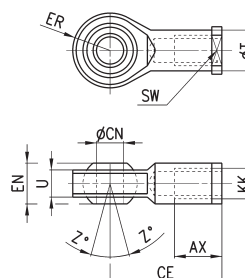

DIMENSIONS

Mod.	Ø	ØCN ^(H7)	U	EN	ER	AX	CE	KK	ØT	Z	SW
GA-8-10	8-10	5	6	8	9	10	27	M4x0.7	9	6.5°	9
GA-12-16	12-16	6	7	9	10	12	30	M6X1	10	6.5°	11
GA-20	20	8	9	12	12	16	36	M8X1.25	12.5	6.5°	14
GA-32	25	10	10.5	14	14	20	43	M10X1.25	15	6.5°	17

Piston rod socket joint Mod. GY

ISO 8139

Material: zama and zinc-plated steel.

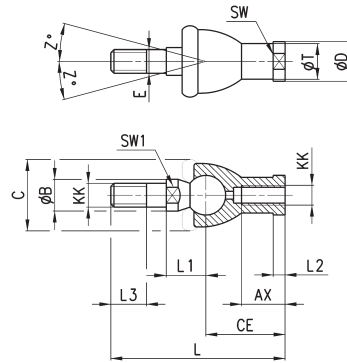

DIMENSIONS

Mod.	ϕ	Z	E	SW	ϕT	ϕD	ϕC	ϕB	KK	L3	SW1	L1	L	CE	AX	L2
GY-12-16	12-16	15	6	11	10	13	20	10	M6X1	11	8	12,2	55	28	15	5
GY-20	20	15	8	14	12,5	16	24	12	M8X1,25	12	10	16	65	32	16	5
GY-32	25	15	10	17	15	19	28	14	M10X1,25	15	11	19,5	74	35	18	6,5

Piston rod lock nut Mod. U

ISO 4035

Material: zinc-plated steel.

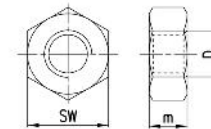

DIMENSIONS

Mod.	ϕ	SW	m	D
U-8-10	8-10	7	3	M4X0,7
U-12-16	12-16	10	4	M6X1
U-20	20	13	5	M8X1,25
U-25-32	25	17	6	M10X1,25

Nose nut Mod.V

ISO 4035

Material: zinc-plated steel.

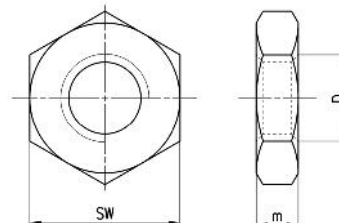

DIMENSIONS

Mod.	ϕ	D	m	SW
V-8-10	8-10	M12X1,25	5	19
V-12-16	12-16	M16X1,5	6	24
V-20-25	20-25	M22X1,5	10	32

Self aligning rod Mod. GK

Material: zinc-plated steel.

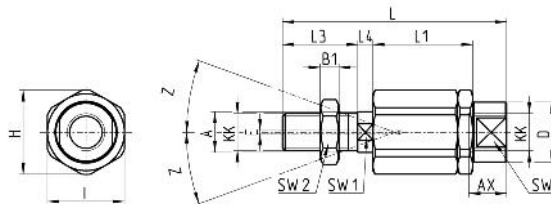
DIMENSIONS

Mod.	∅	H	I	Z	∅A	KK	E	L	L3	L4	L1	B1	SW2	SW1	AX	SW	∅D
GK-20	20	19	17	4	8	M8x1,25	2	57	21	5	26	4	13	7	16	11	12,5
GK-25-32	25-32	32	30	4	14	M10x1,25	2	71,5	20	7,5	35	5	17	12	22	19	22

Coupling piece Mod. GKF

Material: zinc-plated steel.

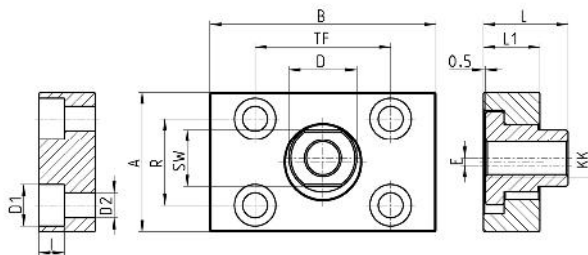
DIMENSIONS

Mod.	∅	∅ D1	I	∅ D2	A	R	SW	B	TF	∅ D	E	L	L1	KK
GKF-20	20	5,5	-	-	30	20	13	35	25	14	1,5	22,5	10	M8x1,25
GKF-25-32	25	11	6,8	6,6	37	23	15	60	36	18	2	22,5	15	M10x1,25