



## 2 and 3-way Ball Valves

- Various types of valve bodies
- Full flow aperture
- Can also be supplied with DVGW approval

Manual ball valve in brass and stainless steel for shutting off and distributing medium flows.

### Versions

- Manual shut-off ball valve, full flow aperture
- Ball valve DVGW approved
- Mini lux ball valve with rotary wing
- Ball valve with rotary wing, full flow aperture
- 3-way ball valve with L or T bore, full flow aperture
- Stainless steel ball valve

Technical data	
Orifice	DN6 - DN100
Body material	brass, nickel-plated stainless steel
Ball material	brass, hard-chrome plated stainless steel
Sealing material	PTFE
Pressure range <sup>1)</sup>	technical vacuum (10 <sup>-3</sup> Torr) to nominal pressure PN (see Ordering charts)
Temperature range	see ordering charts

<sup>1)</sup> Pressure data [bar]: Overpressure with respect to atmospheric pressure

## Ordering charts 2- and 3-way ball valves, brass body

Manual shut-off ball valve, full flow aperture, Internal thread, bilateral

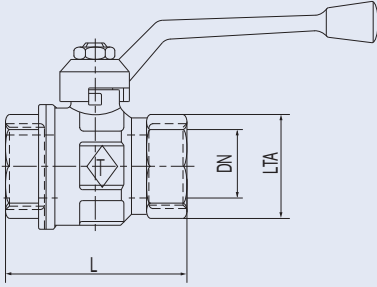
TKU001	Materials	Temperature range	DN	LTA	L	Kv value	PN	Item no.
			[mm]		[mm]	[m <sup>3</sup> /h]	[bar]	
	Body: brass, nickel-plated Ball: brass, hard-chrome plated Seal: PTFE Lever: aluminium, plastic coated	-20°C to +160°C	8	1/4	51.5	5.4	64	780 230
			10	3/8	51.5	6.0	64	780 231
			15	1/2	55.0	16.3	30	780 232
			20	3/4	57.0	29.5	30	780 233
			25	1	69.5	43.0	30	780 234
			32	1 1/4	81.5	89	25	781 746
			40	1 1/2	95	230	25	781 747
			50	2	113	265	25	781 748

Ball valve, DVGW approval (DIN DVGW-NG-4312AT0469), full flow aperture

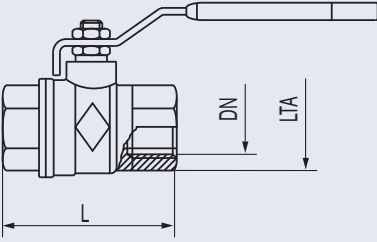
TKU001	Materials	Temperature range	DN	LTA	L	Kv value	PN	Item no.
			[mm]		[mm]	[m <sup>3</sup> /h]	[bar]	
	Body: brass, nickel-plated Ball: brass, hard-chrome plated Seal: PTFE Lever: aluminium, anodised, yellow coated	-10°C to +70°C	8	1/4	51.5	5.4	5	788 771
			10	3/8	51.5	6	5	781 646
			15	1/2	62	16.3	5	781 647
			20	3/4	69	29.5	5	781 648
			25	1	83	43	5	781 649
			32	1 1/4	96	89	5	781 650
			40	1 1/2	108	230	5	781 651
			50	2	126	265	5	781 652

Mini lux ball valve with rotary wing, Internal thread, bilateral

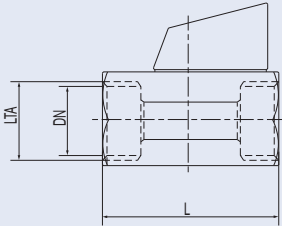
TKU001	Materials	Temperature range	DN	LTA	L	Kv value	PN	Item no.
			[mm]		[mm]	[m <sup>3</sup> /h]	[bar]	
	Body: brass, nickel-plated Ball: brass, hard-chrome plated Seal: PTFE	-20°C to +160°C	6	1/8	41	4.3	10	781 653
			8	1/4	41	4.3	10	781 654
			8	3/8	41	4.3	10	781 655
			10	1/2	46	4.3	10	781 656

Ordering charts 2- and 3-way ball valves, brass body, cont.

Mini lux ball valve with rotary wing, Internal and external thread

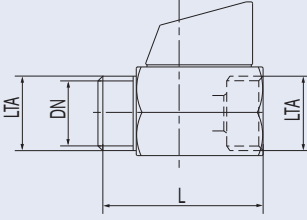
TKU001	Materials	Temperature range	DN	LTA	L	Kv value	PN	Item no.
			[mm]		[mm]	[m <sup>3</sup> /h]	[bar]	
	Body: brass, nickel-plated Ball: brass, hard-chrome plated Seal: PTFE	-20°C to +160°C	8	1/8	41	4.3	10	781 657
			8	1/4	41	4.3	10	781 658
			8	3/8	41	2.7	10	781 659
			10	1/2	46	5.4	10	781 660

Ball valve with rotary wing, full bore, Internal thread, bilateral

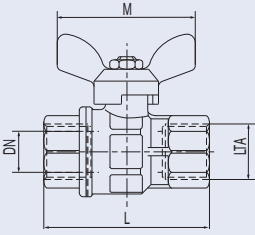
TKU001	Materials	Temperature range	DN	LTA	L	M	Kv value	PN	Item no.
			[mm]		[mm]	[mm]	[m <sup>3</sup> /h]	[bar]	
	Body: brass, nickel-plated Ball: brass, hard-chrome plated Seal: PTFE Lever: aluminium	-20°C to +160°C	8	1/4	51.5	50	5.4	64	781 752
			10	3/8	51.5	50	6.0	64	781 753
			15	1/2	62	50	16.3	30	781 754
			20	3/4	69	64	29.5	30	781 755
			25	1	83	94	43	30	781 756

3-way Ball valve with L or T bore, full flow aperture

Switch positions  
T-bores

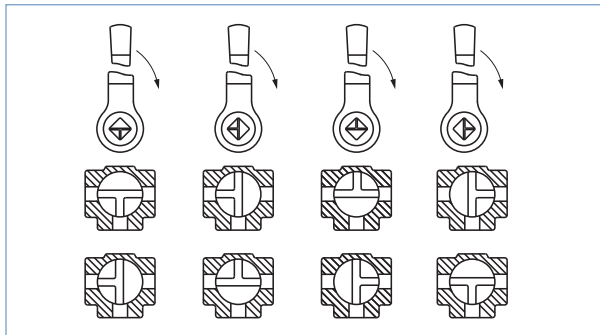

Switch positions  
L-bores

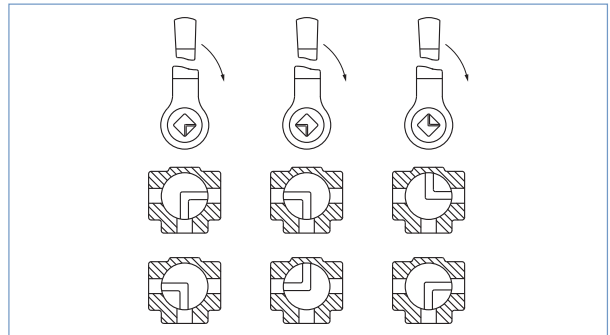

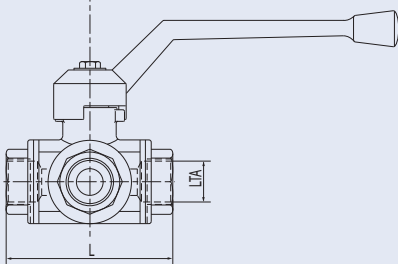
TKU002	Materials	Temperature range	DN	LTA G	L	Kv value	PN	Item no. L bore
			[mm]		[mm]	[m <sup>3</sup> /h]	[bar]	
	Body: brass, nickel-plated Ball: brass, hard-chrome plated Seal: PTFE Lever: aluminium	-20°C to +160°C	8	1/4"	80.5	2.8	40	781 762
			10	3/8"	80.5	3	40	781 763
			15	1/2"	80.5	3.6	40	781 764
			20	3/4"	93.4	6	40	781 765
			25	1"	107.3	11	25	781 766
			32	1 1/4"	118	16	16	781 767
			40	1 1/2"	141	25.5	16	781 768
50	2"	169	37.5	16	781 769			

## Ordering charts 2- and 3-way ball valve, brass body, cont.

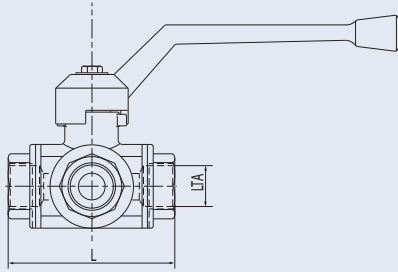
TKU003	Materials	Temperature range	DN	LTA G	L	Kv value	PN	Item no.
			[mm]		[mm]	[m <sup>3</sup> /h]	[bar]	T bore
	Body: brass, nickel-plated Ball: brass, hard-chrome plated Seal: PTFE Lever: aluminium	-20°C to +160°C	8	1/4"	80.5	3	40	781 770
			10	3/8"	80.5	3.5	40	781 771
			15	1/2"	80.5	4.3	40	781 772
			20	3/4"	93.4	6.6	40	781 773
			25	1"	107.3	12.2	25	781 774
			32	1 1/4"	118	16.9	16	781 775
			40	1 1/2"	141	26.3	16	781 776
			50	2"	169	38.2	16	781 777

Ordering charts 2- and 3-way ball valves, stainless steel body

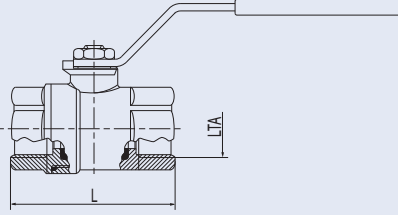
TKU001 	Materials	Temperature range	DN	LTA G	L	Kv value	PN	Item no.
			[mm]		[mm]	[m³/h]	(80°C) [bar]	
	Body: stainless steel AISI 351-CF 8M Ball: Stainless steel AISI 351 Seal: PTFE O Ring: FKM Lever: stainless steel AISI 430	-20°C to +160°C	8	1/4"	53.5	5.4	64	781 824
			10	3/8"	53.5	6	64	781 825
			15	1/2"	60	16.3	64	781 826
			20	3/4"	70	29.5	40	781 827
			25	1"	79	43	40	781 828
			32	1 1/4"	91	89	25	781 829
			40	1 1/2"	103	230	25	781 830
			50	2"	124	265	25	781 831

3-way ball valve with L or T bore, reduced flow with flange mounting, ISO 5211 and hand lever

Switch positions

T-bores

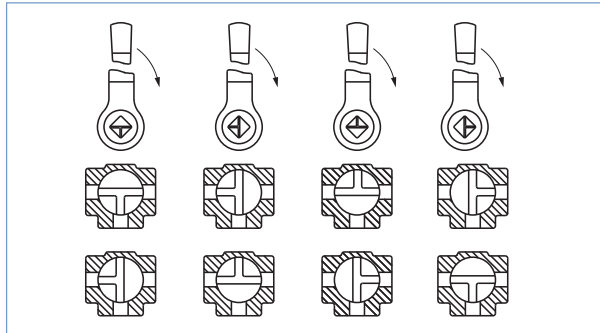

Switch positions

L-bores

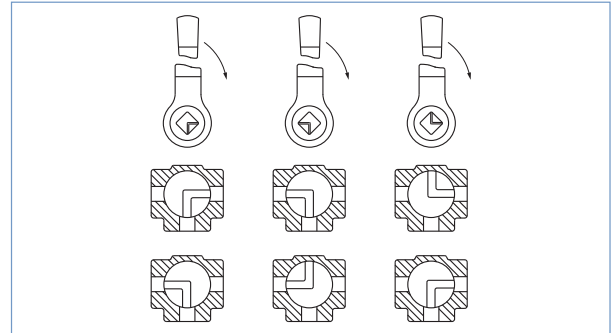

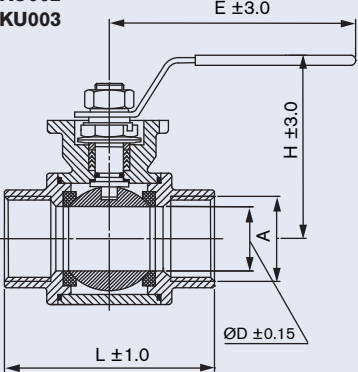
TKU002 TKU003 	Materials	Temperature range	DN	LTA G	L	Kv value	PN	Item no. L bore	Item no. T bore
			[mm]		[mm]	[m³/h]	[bar]		
	Body: stainless st. 1.4401 Ball: stainless st. 1.4401 Seal: PTFE O Ring: FKM Lever: stainless st. 1.4301	-20°C to +150°C	11	1/4"	80.5	2.8	63	789 439	789 446
			12	3/8"	80.5	3	63	789 493	789 447
			12	1/2"	80.5	3.6	63	789 331	789 448
			15	3/4"	88	6	63	789 441	789 449
			20	1"	100	11	63	789 442	789 397
			25	1 1/4"	123	16	63	789 443	789 450
			32	1 1/2"	140	25.5	63	789 444	789 451
			40	2"	170	37.5	63	789 445	789 452

## Ordering charts 2- and 3-way ball valve, stainless steel body, cont.

## 3-piece, Threaded port

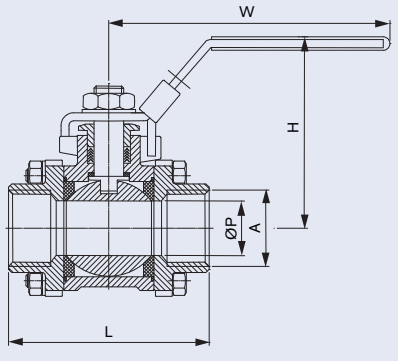
TKU001	Materials	Temperature range			L [mm]	Kv value [m <sup>3</sup> /h]	PN [bar]	Item no.
			DN [mm]	LTA G				
	Body: stainless st. 1.4408	-20°C to +200°C	8	1/4"	60	5.4	63	789 453
			10	3/8"	60	6	63	789 454
	Ball: stainless st. 1.4401		15	1/2"	75	16.3	63	789 455
	Seal: PTFE		20	3/4"	80	29.5	63	789 456
	O Ring: FKM		25	1"	90	43	63	789 457
	Lever: stainless st. 1.4301		32	1 1/4"	110	89	63	789 458
			40	1 1/2"	120	230	63	789 459
			50	2"	140	265	63	789 460
			65	2 1/2"	185	540	63	789 461
			80	3"	205	880	63	789 373
			100	4"	240	1380	63	789 463

## 3-piece, Weld end connection

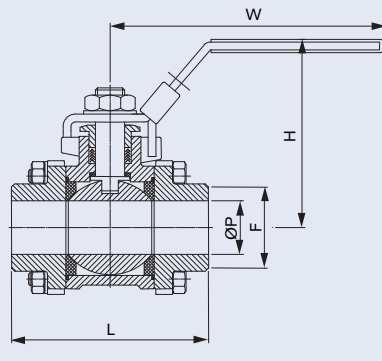
TKU001	Materials	Temperature range				L [mm]	Kv value [m <sup>3</sup> /h]	PN (80°C) [bar]	Item no.
			DN [mm]	P Ø [mm]	F [mm]				
	Body: stainless st. 1.4408	-20°C to +200°C	8	11.6	12.5	65	5.4	63	789 464
			10	12.7	15	70	6	63	789 465
	Ball: stainless st. 1.4401		15	16	18	75	16.3	63	789 430
	Seal: PTFE		20	20	22	90	29.5	63	789 467
	O Ring: FKM		25	25	28	100	43	63	789 468
	Lever: stainless st. 1.4301		32	32	35	110	89	63	789 469
			40	38.1	43	125	230	63	789 470
			50	50.8	54	150	265	63	789 471
			65	65	69	190	540	63	789 472
			80	80	84	220	880	63	789 473
			100	100	104	270	1380	63	789 474