

## Swing check valve for water



- Brass body
- Metal seal

Swing check valve with metal seal for horizontal installation.  
For opening is a pressure difference of 0.1 bar required.

Technical Data	
<b>Orifice</b>	DN 15 - 50 mm
<b>Body material</b>	CW 617N
<b>Disc</b>	CW 617N
<b>Seal</b>	Metallic
<b>Pressure</b>	Max. 10 bar <sup>1)</sup> bei +20 °C
<b>Opening pressure</b>	Pressure difference > 0,1 bar
<b>Medium temperature</b>	Max. +110 °C
<b>Installation</b>	Horizontal

<sup>1)</sup> Pressure values [bar]: Measured as overpressure with respect to the atmospheric pressure.

## Ordering chart

---

DN [mm]	Port connection	L [mm]	H [mm]	SW [mm]	Item no.
15	R 1/2	47.0	32.0	20.0	783 458
20	R 3/4	53.0	34.0	26.5	783 459
25	R 1	64.0	40.0	26.0	783 460
32	R 1 1/4	74.0	47.0	34.5	783 461
40	R 1 1/2	87.0	54.0	39.5	783 462
50	R 2	97.0	57.0	49.5	783 463

Further versions on request

## Dimensions [mm]

---

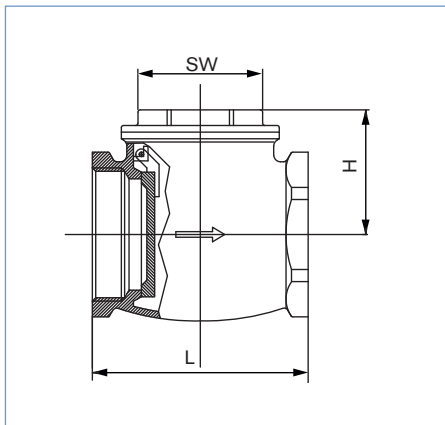

See ordering chart above for dimensions.