

8697 Pneumatic Control Unit/Feedback



Type 8697 can be combined with...



Type 2100

Angle seat valve

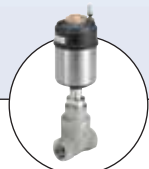

Type 2101

Globe seat valve



Type 2103

Diaphragm valve



Type 2000

Angle seat valve

Pneumatic Control/Feedback

- Compact design
- Integrated pilot valve with manual override
- Internal control air routing
- Bright LED position indicator
- Automatic end position adjustment

The 8697 pneumatic control unit is optimised for integrated mounting on the ELEMENT 21XX process valve and CLASSIC 20xx series. Mechanical or inductive limit switches register the position of the valve. The integrated pilot valve controls single-acting actuators.

The design of the control unit and the actuator enables an internal control air routing without external tubings. Besides the electrical position feedback signal the status of the device is shown directly on the control head itself via LEDs.

The housing is easy to clean and features proven electrical IP protection and chemically resistant materials for use in hygienic processing, in food, beverage and pharmaceutical industries. Combined with Bürkert ELEMENT actuators the unique pilot valve system enables a compressed air recycling that avoids actuator chambers contamination from the environment.

Technical Data	
Material -Body Cover Sealing	PPS PC EPDM
Operating voltage Pilot valve Micro switch Initiator	24 V DC $\pm 10\%$ - residual ripple 10%, consumption 1 W 24V Version: 0 – 48 V AC/DC, max. 2 A 230V Version: 50 – 250 V AC/DC, max. 2 A 10 to 30 V DC - max.100 mA per initiator
Control medium Dust concentration Particle density Pressure condensation point Oil concentration	neutral gases, air quality class DIN ISO 8573-1 Class 5: max. particle size 40 μm Class 5: max. particle density 10 mg/m^3 Class 3: max. $-20\text{ }^\circ\text{C}$ or min. $10\text{ }^\circ\text{C}$ below the lowest operating temperature Class 5: max. 25 mg/m^3
Supply pressure	3 to 7 bar ¹⁾
Pilot air ports	Threaded ports G 1/8 or push-in connector (tube \varnothing 6 mm / 1/4")
Position feedback	2x micro switch (0 – 48 V AC/DC, max. 2A) 2x micro switch (50 – 250 V AC/DC, max. 2 A) 2x initiator (24 V DC), PNP shutter 3-wire 2x initiator NAMUR (8,2 V DC) (2-wire) 2x initiator (24 V DC), Schließer (2-wire)
Stroke range valve spindle	2 to 36 mm
Ambient temperature with/without pilot valve with/without pilot valve with pilot valve without pilot valve	0 to $+55\text{ }^\circ\text{C}$ (II 3D Ex tc IIIC T135°C Dc, II 3G Ex nA IIC T4 Gc) 0 to $+55\text{ }^\circ\text{C}$ (II 2D Ex ia IIIC T135°C Db IP64, II 2G Ex ia IIC T4 Gb) -10 to $+55\text{ }^\circ\text{C}$ (II 2G Ex ia IIC T4 Gb) -20 to $+60\text{ }^\circ\text{C}$ (II 2G Ex ia IIC T4 Gb)
Installation	as required, preferably with actuator in upright position
Protection category	IP65 and IP67 according to EN 60529
Protection class	3 according to VDE 0580
Conformity	according to CE in compliance with EMV 2004/108/EG
Ignition protection	II 3D Ex tc IIIC T135°C Dc II 3G Ex nA IIC T4 Gc II 2D Ex ia IIIC T135°C Db IP64 II 2G Ex ia IIC T4 Gb
Electrical connection Multipole Cable gland	M12, 8-pole M16x1.5 SW22 (cable diameter 5 -10 mm), terminal screws 0.14 bis 1.5 mm^2

¹⁾ The supply pressure has to be 0.5 - 1 bar above the minimum required pilot pressure for the valve actuator.

**8697
Pneumatic Control
Unit/Feedback**

Ordering information for process valve system with integrated pneumatic control unit







A complete process valve system consists of a pneumatic control unit Type 8697 and a process valve Type ELEMENT 21xx or CLASSIC 20xx. The following information is necessary for the selection of a complete system:

- **Item no.** of the desired pneumatic control unit **Type 8697** (see Ordering chart)
- **Item no.** of the selected process valve **Type 21xx or Type 20xx**

If you order two components, you receive a complete assembled and certified valve.

When you click on the orange box "More info." below, you will come to our website for the resp. product where you can download the datasheet.

Example for process valve systems

<p>Pneumatic Control Unit Type 8697</p> 	<p>Desired process valve, example</p> <div style="text-align: center;">  <p>More info.</p> <p>2100 Angle-seat valve</p> </div>	<div style="text-align: center;">  <p>More info.</p> <p>2103 Diaphragm valve</p> </div>	<div style="text-align: center;">  <p>More info.</p> <p>2000 Angle-seat valve</p> </div>
<p>Complete process valve system</p>			
	 <p>Process valve system On/Off ELEMENT Type 8801-YE-U 2100+8697</p>	 <p>Process valve system On/Off ELEMENT Type 8801-DF-U 2103+8697</p>	 <p>Process valve system On/Off Classic Type 8801-YA-U 2000+8697</p>

8697
Pneumatic Control
Unit/Feedback

Ordering chart (other versions on request)

End position feedback					Electrical connection	ATEX / IECEX Cat. 3D/G Zone 22/2 ²⁾	ATEX / IECEX Cat. 2D/G Zone 21/1 ³⁾	ATEX / IECEX Cat. 2G Zone 1 ⁴⁾	Pilot air ports threaded ports	Item no.	
Inductive Switch 3-wire PNP	Inductive Switch 2-wire NAMUR	Inductive Switch 2-wire 24V DC	Micro Switch 24V DC	Micro Switch 50-250V AC/DC						Actuator series ELEMENT Type 21xx	Actuator series CLASSIC Types 20xx
Pneumatic Control Unit (pilot valve 3/2-way, single acting NO/NC)											
2									G1/8	248 816	na
2					Cable gland				G1/8 / M5	na	248 829
2						yes			G1/8	255 847	na
2						yes			G1/8 / M5	na	255 853
2						yes			G1/8	255 849	na
2					M12 connector	yes			G1/8 / M5	na	255 855
2									G1/8	248 818	na
2									G1/8 / M5	na	248 830
	2						yes		G1/8	248 822	na
	2						yes		G1/8 / M5	na	248 832
	2							yes	G1/8	255 862	na
	2				Cable gland			yes	G1/8 / M5	na	255 864
		2							G1/8	248 814	na
		2							G1/8 / M5	na	248 828
		2				yes			G1/8	255 845	na
		2				yes			G1/8 / M5	na	255 852
Without end position feedback					M12 Multipole				G1/8	260 278	na
					Cable gland				G1/8	260 279	na
						yes			G1/8	260 280	na
Feedback (without pilot valve)											
2									G1/8	248 812	na
2					Cable gland				without	na	248 827
2						yes			G1/8	255 843	na
2						yes			without	na	255 851
2						yes			G1/8	255 857	na
2					M12 connector	yes			without	na	255 858
2									G1/8	250 471	na
2									without	na	250 472
	2						yes		G1/8	248 820	na
	2						yes		without	na	248 831
	2							yes	G1/8	255 860	na
	2							yes	without	na	255 863
		2							G1/8	248 810	na
		2			Cable gland				without	na	248 826
		2				yes			G1/8	255 841	na
		2				yes			without	na	255 850
			2						G1/8	248 824	na
			2						without	na	248 833
				2					G1/8	248 808	na
				2					without	na	248 825

²⁾ II 3D Ex tc IIIC T135 / II 3G Ex nA IIC T4 Gc

³⁾ II 2D Ex ia IIIC T135°C Db IP64 / II 2G Ex ia IIC T4 Gb

⁴⁾ II 2G Ex ia IIC T4 Gb

i Further versions on request

Approvals
cULus
FM

Additional
Feedback switchpoint NPN-coded
NEMA4x
Push-in pilot air ports (tube Ø 6mm; 1/4")

8697 Pneumatic Control Unit/Feedback

Ordering chart adapter kit (has to be ordered separately)

Description	Actuator size	Control function	Item no.
Adapter kit ELEMENT Types 21xx	Ø50mm	single acting / universal	682 259
Adapter kit CLASSIC Types 20xx	Pneumatic Control Unit	Ø40mm	682 254
	Pneumatic Control Unit	Ø50mm Seat valve types 2000 / 2012	682 255
	Pneumatic Control Unit	Ø50mm Diaphragm valve types 2030 / 2031	682 258
	Pneumatic Control Unit	Ø63mm ⁵⁾	682 256
	Feedback	Ø40mm	682 263
	Feedback	Ø50/63/80mm	682 264
	Feedback	Ø100/125mm	682 265
	Feedback	Ø175/225mm	684 944

For installation kits to 3rd party process valves please see datasheet "Installation Kits for hygienic process valves" or contact your sales office for related drawings or individual engineering support

⁵⁾ When combining actuator size Ø 63 mm with 8697 CLASSIC reduced switching dynamics should be expected. Please choose Type 8690 for shorter response times.

Ordering chart accessories

Description	Item no.
M12 socket, 8-pins, 2m assembled cable	919 061
M12 socket, 8-pins, 5m assembled cable	919 267
Silencer G1/8	780 779
Silencer, push-in connector	902 662
Stroke limitation actuator CLASSIC Ø50/63mm	689 353
Stroke limitation actuator CLASSIC Ø80mm	689 354
Stroke limitation actuator CLASSIC Ø100/125mm	689 355

Materials

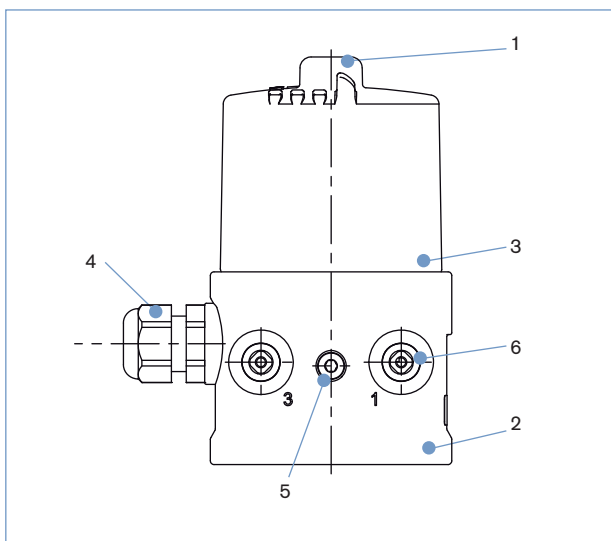

1	Transparent cap	PC
2	Basic body	PPS
3	Sealing	EPDM
4	Cable gland	PA
	Plug M12	Brass nickel plated
5	Screws	Stainless steel
6	Push-in connector	POM / stainless steel
	Threaded ports G1/8	stainless steel

**8697
Pneumatic Control
Unit/Feedback**

Dimensions [mm]

Pneumatic Control Unit/Feedback for mounting on process valve ELEMENT Types 21xx

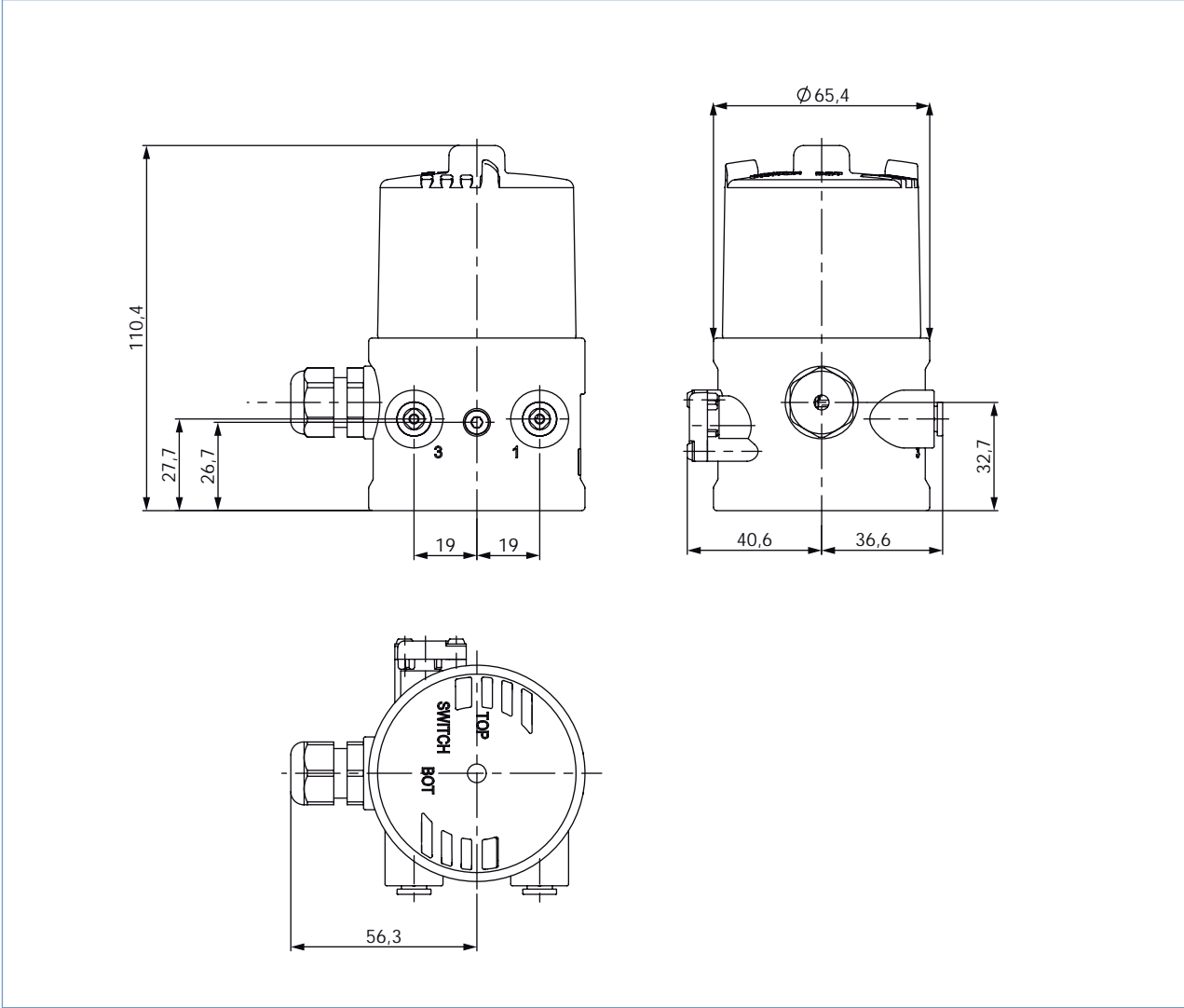

**8697
Pneumatic Control
Unit/Feedback**

Dimensions [mm]

Control Unit for mounting on process valve CLASSIC Types 20xx

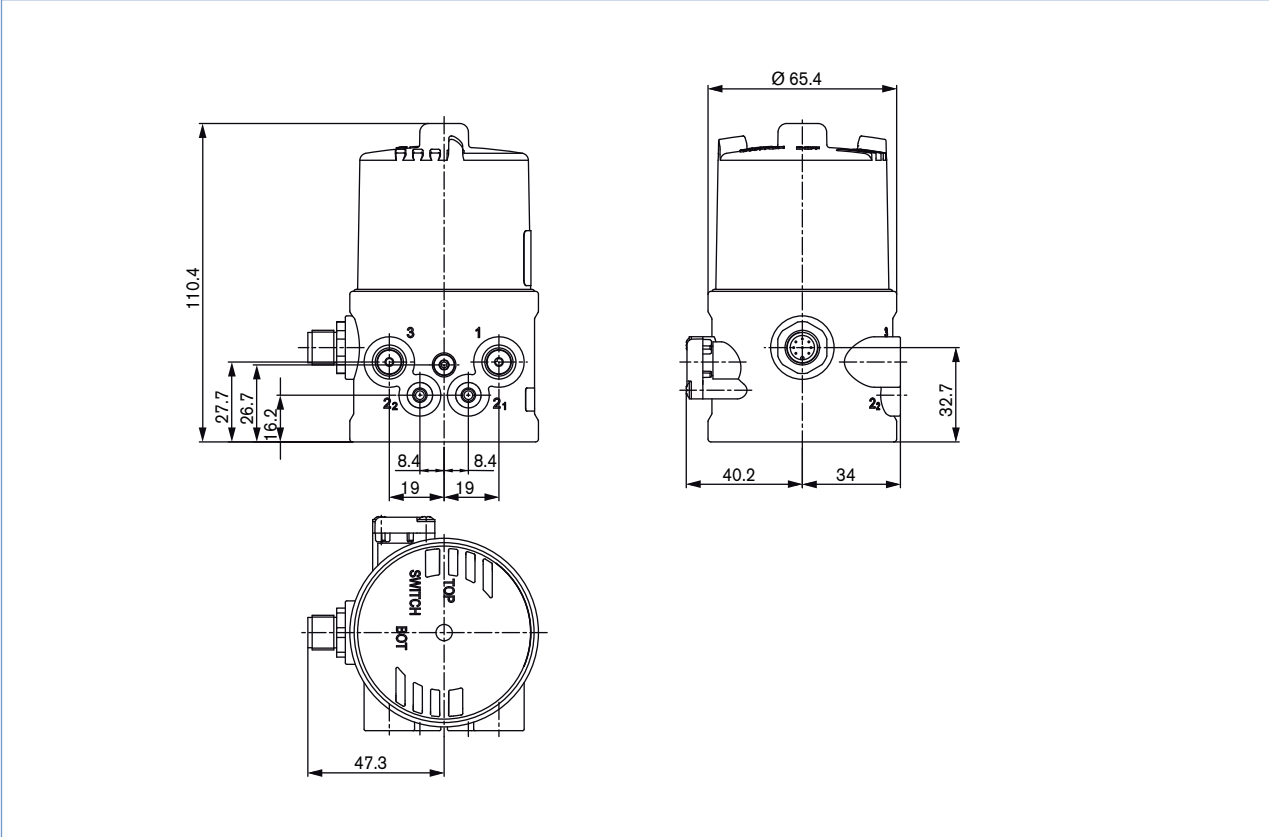

Feedback for mounting on process valve CLASSIC Types 20xx

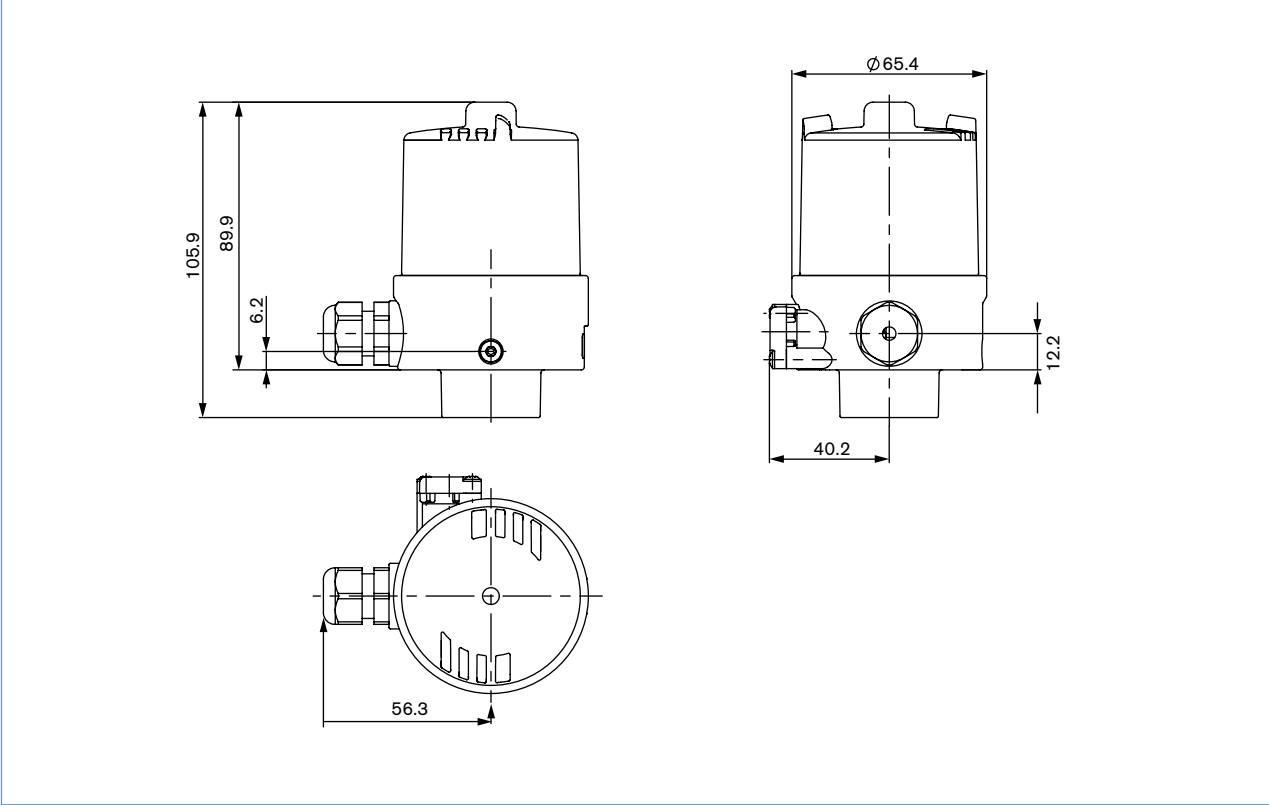

Connection options

Multipole, plug M12 8-pins

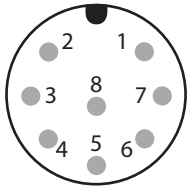

Plug configuration with 3-wire inductive switch, 24 V DC

Pin no.	Wire colour ⁶⁾	Configuration	External circuit
1	white	INI Bottom OUT Output 1	
2	brown	INI Top OUT Output 2	
3	green	INI - (GND) Supply	
4	yellow	INI + (24 V DC) Supply	
5	grey	Valve control 0/24 V	
6	pink	Valve control GND	

⁶⁾ The indicated colours refer to the connecting cable available as an accessory (919 061)

Cable gland , M16 x 1.5 (cable-ø 10 mm), terminal screws (1.5 mm²)



Screw terminals

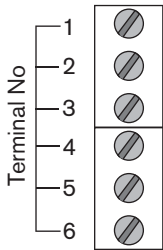

Port configuration with micro switch, 24 V DC / 250 V AC/DC

Terminal	Configuration	External circuit
1	Micro switch top	1 - NO
2		2 - NC
3		3 - Joint connection
4	Micro switch bottom	4 - NO
5		5 - NC
6		6 - Joint connection

Port configuration with 3-wire inductive switch, 24 V DC

Terminal	Configuration	External circuit
1	INI + (24 V DC) Supply	
2	INI GND Supply	
3	INI Top OUT Output 1	
4	INI Bottom OUT Output 2	
5	Valve control 0/24 V DC	
6	Valve control GND	

Port configuration with 2-wire inductive proximity switches

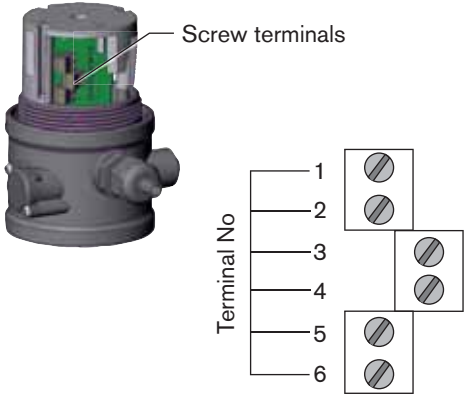

2-wire inductive proximity switches (NAMUR)

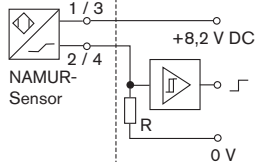
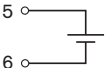
Terminal	Configuration	External circuit
1	INI Top +	<div style="display: flex; justify-content: space-between;"> <div style="width: 45%;"> <p>Explosion protected area</p>  </div> <div style="width: 45%;"> <p>Non-hazardous area</p> </div> </div>
2	INI Top -	
3	INI Bottom +	
4	INI Bottom -	
5	Valve control +	
6	Valve control GND	

2-wire inductive proximity switches, 24 V

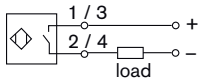
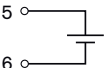
Terminal	Configuration	External circuit
1	INI Top +	
2	INI Top -	
3	INI Bottom +	
4	INI Bottom -	
5	Valve control +	
6	Valve control GND	

⁷⁾ (Acc. to NAMUR recommendation). Please note the prototype test certificate from Turck KEMA 02 ATEX 1090X

⁸⁾ Barrier signal, see PTB 07 ATEX 2048