



2/2 and 3/2-way Rocker Solenoid Valve for analytical applications

- 16 mm width
- Orifice DN 2.0 - DN 3.0
with pressure range vacuum to 5 bar
- Medium separation, for aggressive fluids
- High back-pressure tightness
- Direct acting

Type 6626 combines the reliable and successful Rocker principle with a highly innovative new actuator. The TwinPower concept of this actuator reduces the size greatly without loss in performance. Hence the 16 mm wide medium isolated rocker valve, 6626, with a 3.0 mm orifice and a pressure resistance of 2 bar, provides the same performance as a traditional 22 mm valve. In addition, the integrated power reduction decreases the energy consumption by 75%. In combination with other design features the heat transfer into the medium can be reduced to a minimum.

In the design of the 6626, the main benefits lie in its excellent cleanability and a high reliability. By using high performance materials the 6626 suits the handling of aggressive medium perfectly. The valve is available in a 2-way and 3-way version.

Circuit function A

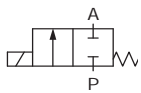

2/2-way valve,
direct acting,
normally closed

Circuit function B

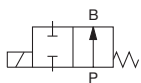

2/2-way valve,
direct acting,
normally open

Circuit function T

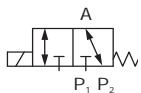

3/2-way valve,
universal function

Technical Data	
Orifice	DN 2.0 mm, DN 3.0 mm
Body material	PEEK, PPS
Seal material	FFKM, FKM, EPDM
Medium	Resistant to neutral and aggressive gases and liquids acc. to our chemical resistance chart
Medium temperature	
FFKM	+15 °C to +50 °C
FKM	-10 °C to +50 °C
EPDM DN 2.0	-10 °C to +50 °C
EPDM DN 3.0	+5 °C to +50 °C
Ambient temperature	
FFKM	+15 °C to +55 °C
FKM	-10 °C to +55 °C
EPDM DN 2.0	-10 °C to +55 °C
FFKM DN 3.0	+5 °C to +55 °C
Internal volume	<470 µl
Port connection	Sub-base, UNF, G 1/8, Tube
Electrical connection	Flying leads, Rectangular plug
Power supply	24 V ¹⁾ , 12 V ¹⁾
Voltage tolerance	24V ±10% ²⁾ 12V +10% / -5% ²⁾
Nominal power consumption	13.6W inrush power 3.4W nominal holding power (internal power reduction)
Duty cycle	100% continuous rating
Installation	As required
Protection class	IP 40
Switching frequency	max. 2 Hz ³⁾
Response times³⁾	
opening	ca. 10 ms (Pressure rise 0-10%)
closing	ca. 15 ms (Pressure drop 100-90%)

¹⁾ Battery voltage, observe polarity (red= +, black = -)

²⁾ Max. allowed ripple

³⁾ with ambient temperature of 20° C

Ordering chart

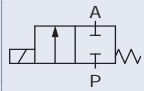
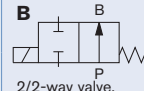
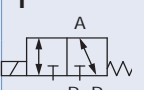
Circuit function	Orifice [mm]	Port connection	Kv value water [m ³ /h] ¹⁾	Pressure range [bar] ²⁾	Max. pressure difference [bar]	Seal material	Body material	Electrical connection	Voltage/Frequency [V/Hz]	Item no.		
A  2/2-way valve, direct acting, NC	2.0	Sub-base	0.10	vac - 3 (vac - 5)	3 (5)	EPDM	PPS	Rectangular Plug ³⁾	12	247 769		
										24	247 771	
		UNF		vac - 3 (vac - 3)	3 (3)	FFKM	PEEK	Flying Leads	24	12	247 775	
				vac - 3 (vac - 4)	3 (4)	FKM	PPS			247 786		
				vac - 3 (vac - 3)	3 (3)	FFKM	PEEK			251 709		
	G 1/8	vac - 3 (vac - 4)	3 (4)	FKM	PEEK	Rectangular Plug ³⁾	24	252 770				
		vac - 3 (vac - 3)	3 (3)	FFKM		Flying Leads		234 278				
	3.0	Sub-base	0.19	0.19			EPDM	PPS	Rectangular Plug ³⁾	24	247 797	
							FFKM	PEEK			238 530	
							FKM	PPS			12	247 816
UNF		vac - 2 (vac - 2)			2 (2)	FFKM	PEEK	Flying Leads	24	247 819		
						FKM				251 711		
						FKM				252 771		
Tube					EPDM		Rectangular Plug ³⁾	24	247 789			
					FFKM		Flying Leads		228 642			
					FKM		Rectangular Plug ³⁾		247 810			
B  2/2-way valve, direct acting, normally open	2.0	Sub-base	0.10	vac - 3 (vac - 3)	3 (3)	FFKM	PEEK	Flying Leads	24	252 773		
	3.0		0.19	vac - 2 (vac - 2)	2 (2)					Rectangular Plug ³⁾	245 910	
T  3/2-way valve, direct acting, Universal version	2.0	Sub-base	0.10	vac - 3 (vac - 5)	3 (5)	EPDM	PPS	Rectangular Plug ³⁾	24	247 826		
										Flying Leads	12	247 829
		UNF		vac - 3 (vac - 3)	3 (3)	FFKM	PEEK	Flying Leads	24	247 841		
				vac - 3 (vac - 4)	3 (4)	FKM	PPS			Rectangular Plug ³⁾	12	247 838
				vac - 3 (vac - 3)	3 (3)	FFKM	PEEK			251 713		
	G 1/8	vac - 3 (vac - 4)	3 (4)	FKM		Rectangular Plug ³⁾	24	252 774				
						Flying Leads		252 775				
	3.0	Sub-base	0.19	0.19			EPDM	PPS	Rectangular Plug ³⁾	12	247 851	
							FFKM	PEEK	Flying Leads	24	247 853	
							FKM	PPS	Rectangular Plug ³⁾	12	234 371	
		UNF			vac - 2 (vac - 2)	2 (2)	EPDM	PEEK	Rectangular Plug ³⁾	24	247 877	
							FFKM		Flying Leads		252 776	
				FKM	Flying Leads	251 715						
G 1/8						EPDM		Rectangular Plug ³⁾	24	247 872		
						FFKM		Flying Leads		247 859		
					FKM		Rectangular Plug ³⁾	247 858				
Tube							Flying Leads		247 869			

¹⁾ Measured at +20 °C, 1 bar pressure at valve inlet and free outlet.



²⁾ Measured as overpressure with respect to atmospheric pressure.

³⁾ Please order the rectangular plug separately. For selection possibilities see accessories.

Note: () Values in brackets are only for gas mediums.

Ordering chart accessories

Rectangular plug Type 2505

	Accessories	Item no.
	Rectangular plug with 3 m cable	133 486
	Rectangular plug with 300 mm flying leads	644 068
	Rectangular plug, single contact for individual mounting	644 067

Dimensions [mm]

Electrical connections: flying leads

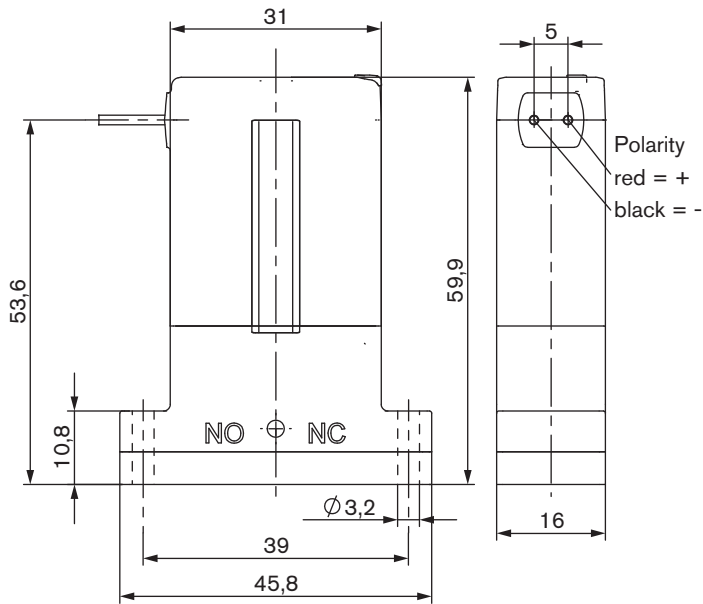

Electrical connections: rectangular plug

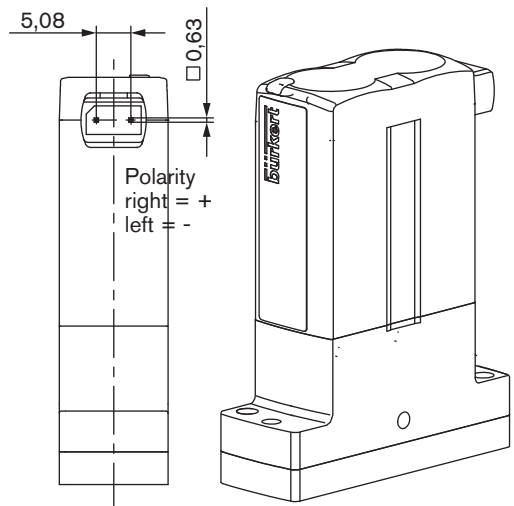

Sub-base body for 3/2-way connection

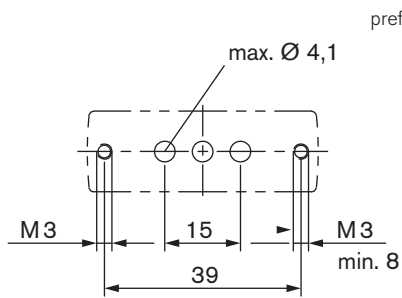

preferred threaded connection

Sub-base body for 2/2-way connection

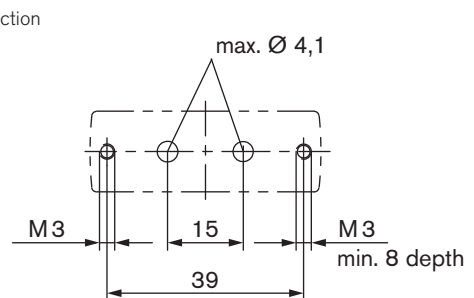

further possible threaded connection

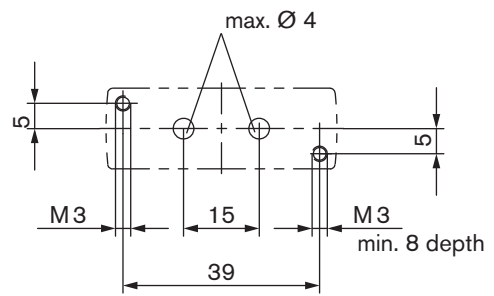
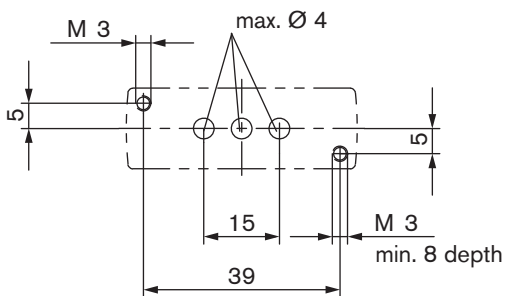

Dimensions [mm]

Body, tube connector

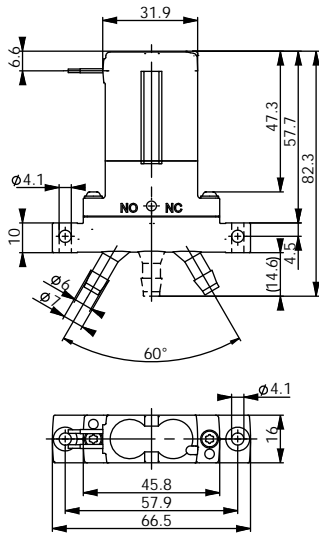

Body, UNF 5/16" -24

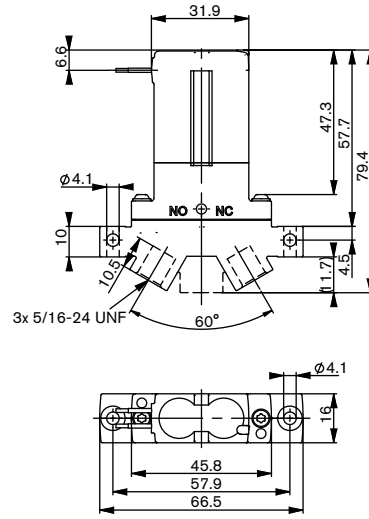

Body, G1/8

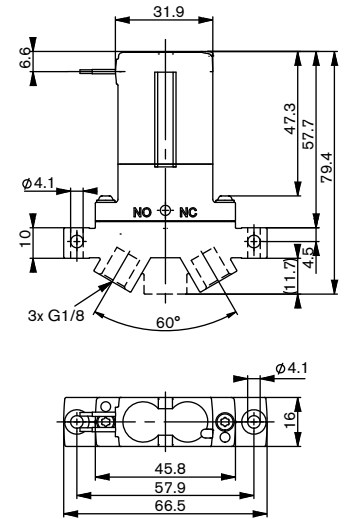

Application examples

Tube 2-way



UNF 2-way



Tube 3-way



UNF 3-way

