

**6519**  
for extended  
temperature range

**3/2-, 5/2-, 5/2-bistable and 5/3-way-Solenoid Valve for Process Pneumatics**



Type 6519 for extended Temperature range can be combined with...



**Type 2012**  
Globe valve



**Type 2030**  
Diaphragm valve



**Type 2508**  
Cable plug

- Suitable for temperatures down to  $-40^{\circ}$  Celsius
- High flow-rate capacity up to 2100 l/min
- Single- and NAMUR-Valves
- Standard-, Ex-i and Ex-m
- G 1/4" Threaded port or NAMUR-flange

Type 6519 is a pilot-controlled 3/2-, 5/2-, 5/2-bistable and 5/3-way-solenoid valve for pneumatics. The valves are as Single- and NAMUR-valves available. They are used to control single- or double-acting actuators. A solenoid valve Type 6014 is used as a pilot.

The materials aluminium and stainless steel enable the use in rough environments, also for extreme temperatures down to  $-40^{\circ}$  C.

General technical data	Aluminium	Stainless steel
<b>Orifice [mm]</b>	6 and 9	6 and 8
<b>Body material main valve</b>	Aluminium, ematal coated	Stainless steel 1.4571
<b>Internal parts material</b>	Brass, Aluminium, Stainless steel	Stainless steel 1.4305
<b>Seal materials</b>	FKM, NBR	FKM, NBR, FPM
<b>Pneumatic connection</b>	Threaded port G1/4 or NAMUR-Flange NPT connector on request	
<b>Electrical connection</b>	Tag connector acc. to DIN EN 175301-803	
<b>Power supply</b>	24 V DC 24/110/230 V, 50-60 Hz	
<b>Voltage tolerance</b>	$\pm 10\%$	
<b>Media</b>	compressed air acc. to ISO 8573-1 class 1-5	
<b>Media temperature</b>	$-30$ to $+ 80^{\circ}$ C	$-30$ to $+ 80^{\circ}$ C
<b>Ambient temperature</b>	$-40$ to $+ 80^{\circ}$ C	$-30$ to $+ 80^{\circ}$ C
<b>Type of protection</b>	with cable plug IP 65	
<b>Installation</b>	As required	

**6519**  
for extended  
temperature range

**bürkert**

**Type 6519 for extended temperature range standard**



Technical Data	Aluminium	Stainless steel
<b>Orifice [mm]</b>	9	8
Body material	Stainless steel	Stainless steel
Pilot valve	Aluminium, ematal coated	Stainless steel 1.4571
Main valve		
<b>Internal parts material</b>	Brass, Aluminium, Stainless steel	Stainless steel 1.4305
<b>Seal materials</b>	FKM, NBR	FKM, NBR, FPM
<b>Pneumatic connection</b>	Threaded port G1/4 or NAMUR-Flange NPT connector on request	
<b>Electrical connection</b>	Tag connector acc. to DIN EN 175301-803	
<b>Power supply</b>	24 V DC 24/110/230 V, 50-60 Hz	
<b>Voltage tolerance</b>	±10%	
<b>Electr. power consumption</b>	2 W (Continuous operation, 100% ED)	
<b>Media</b>	compressed air acc. to ISO 8573-1 class 1-5	
<b>Media temperature</b>	-30 to + 80° C	-30 to + 80° C
<b>Ambient temperature</b>	-40 to + 80° C	-30 to + 80° C
<b>Type of protection</b>	with cable plug IP 65	
<b>Response times</b>	5/2	5/2-bi. 5/3
opening	16ms	18ms 16ms
closing	27ms	18ms 22ms
	3/2	5/2
	13ms	12ms
	47ms	74ms
	5/2-bi.	14ms

**Ordering chart valves in aluminium with manual override (without manual override on request)**

All products come with a standard stainless steel cap nut. This cap nut protects the exhaust channel from penetrating humidity.

Circuit function	Orifice [mm]	Seal material body	Port connection threaded port	Q <sub>N</sub> -value air [l/min]	Pressure range [bar]	Mass [g]	Nominal power [W]	Voltage/frequency [V/Hz]	Item no.
<b>5/2</b> circuit function H	9,0	FKM, NBR	G 1/4	1800	2,5-10	680	2	024/DC	231 386
								024/50-60	231 387
								110/50-60	231 388
								230/50-60	231 389
<b>5/2-bistable</b> circuit function H	9,0	FKM, NBR	G 1/4	2100	2,5-10	990	2	024/DC	231 390
								024/50-60	231 391
								110/50-60	231 392
								230/50-60	231 393
<b>5/3</b> circuit function L	9,0	FKM, NBR	G 1/4	1500	2,5-10	1060	2	024/DC	231 394
								024/50-60	231 395
								110/50-60	231 396
								230/50-60	231 397
<b>5/3</b> circuit function N	9,0	FKM, NBR	G 1/4	1500	2,5-10	1060	2	024/DC	231 399
								024/50-60	231 400
								110/50-60	231 401
								230/50-60	231 402

**6519**  
for extended  
temperature range

**bürkert**

**Ordering chart valves in stainless steel with manual override (without manual override on request)**

All products come with a standard stainless steel cap nut. This cap nut protects the exhaust channel from penetrating humidity.

Circuit function	Orifice [mm]	Seal material body	Port connection threaded port	Q <sub>Nn</sub> -value air [l/min]	Pressure range [bar]	Mass [g]	Nominal power [W]	Voltage/frequency [V/Hz]	Item no.
<b>5/2</b> circuit function H	8,0	FKM, NBR	G 1/4	1980	3–10	1370	2	024/DC	231 403
								024/50–60	231 404
								110/50–60	231 405
								230/50–60	231 406
<b>5/2-bistable</b> circuit function H	8,0	FKM, NBR	G 1/4	1920	3–10	1680	2	024/DC	231 407
								024/50–60	231 408
								110/50–60	231 409
								230/50–60	231 410
<b>5/3</b> circuit function L	8,0	FKM, NBR	G 1/4	1770	3–10	1680	2	024/DC	231 411
								024/50–60	231 412
								110/50–60	231 413
								230/50–60	231 414
<b>5/3</b> circuit function N	8,0	FKM, NBR	G 1/4	1770	3–10	1680	2	024/DC	231 415
								024/50–60	231 416
								110/50–60	231 417
								230/50–60	231 418

**6519**  
for extended  
temperature range

**bürkert**



**Type 6519 for extended temperature range Ex-m standard**



Technical Data	Aluminium	Stainless steel				
<b>Orifice [mm]</b>	9	8				
Body material	Stainless steel	Stainless steel				
Pilot valve	Aluminium, ematal coated	Stainless steel 1.4571				
Main valve						
<b>Internal parts material</b>	Brass, Aluminium, Stainless steel	Stainless steel 1.4305				
<b>Seal materials</b>	FKM, NBR	FKM, NBR, FPM				
<b>Pneumatic connection</b>	Threaded port G1/4 or NAMUR-Flange NPT connector on request					
<b>Electrical connection</b>	Moulded cable, 3 m (non-detachable), Terminal box on request					
<b>Power supply</b>	24/110/230 V/UC					
<b>Voltage tolerance</b>	±10%					
<b>Electr. power consumption</b>	3 W (Continuous operation, 100% ED)					
<b>Media</b>	compressed air acc. to ISO 8573-1 class 1-5					
<b>Media temperature</b>	-30 to + 80° C	-30 to + 80° C				
<b>Ambient temperature</b>	-40 to + 60° C	-30 to + 60° C				
<b>Type of protection</b>	with cable plug IP 65					
<b>Approval</b>	PTB 00 ATEX 2129 X EX M II T4/T5/T6, II 2G, II 2D IP 65					
<b>Response times</b>	5/2	5/2	5/3	3/2	5/2	5/2
opening	16ms	18ms	16ms	13ms	12ms	14ms
closing	27ms	18ms	22ms	47ms	74ms	14ms

**Ordering chart valves in aluminium with manual override (without manual override on request)**

All products come with a standard stainless steel cap nut. This cap nut protects the exhaust channel from penetrating humidity.

Circuit function	Orifice [mm]	Seal material body	Port connection threaded port	Qn-value air [l/min]	Pressure range [bar]	Mass [g]	Nominal power [W]	Voltage/frequency [V/Hz]	Item no.
<b>5/2</b> <b>circuit function H</b>	9,0	FKM, NBR	G 1/4	1800	2,5-10	680	3	024/UC	231 420
								110/UC	231 421
								230/UC	231 422
<b>5/2-bistable</b> <b>circuit function H</b>	9,0	FKM, NBR	G 1/4	2100	2,5-10	990	3	024/UC	231 425
								110/UC	231 426
								230/UC	231 427
<b>5/3</b> <b>circuit function L</b>	9,0	FKM, NBR	G 1/4	1500	2,5-10	1060	3	024/UC	231 429
								110/UC	231 430
								230/UC	231 431
<b>5/3</b> <b>circuit function N</b>	9,0	FKM, NBR	G 1/4	1500	2,5-10	1060	3	024/UC	231 433
								110/UC	231 434
								230/UC	231 435

**6519**  
for extended  
temperature range

**bürkert**

**Ordering chart valves in stainless steel with manual override (without manual override on request)**

All products come with a standard stainless steel cap nut. This cap nut protects the exhaust channel from penetrating humidity.

Circuit function	Orifice [mm]	Seal material body	Port connection threaded port	Q <sub>Nn</sub> -value air [l/min]	Pressure range [bar]	Mass [g]	Nominal power [W]	Voltage/frequency [V/Hz]	Item no.
<b>5/2</b> circuit function H	8,0	FKM, NBR	G 1/4	1980	3-10	1370	3	024/UC	231 437
								110/UC	231 438
								230/UC	231 439
<b>5/2-bistable</b> circuit function H	8,0	FKM, NBR	G 1/4	1920	3-10	1680	3	024/UC	231 441
								110/UC	231 442
								230/UC	231 443
<b>5/3</b> circuit function L	8,0	FKM, NBR	G 1/4	1770	3-10	1680	3	024/UC	231 445
								110/UC	231 446
								230/UC	231 447
<b>5/3</b> circuit function N	8,0	FKM, NBR	G 1/4	1770	3-10	1680	3	024/UC	231 449
								110/UC	231 450
								230/UC	231 451

**6519**  
for extended  
temperature range

**bürkert**



**Type 6519 for extended temperature range Ex-i**



Technical Data	Aluminium	Stainless steel				
<b>Orifice [mm]</b>	9	8				
Body material	Stainless steel	Stainless steel				
Pilot valve	Aluminium, ematal coated	Stainless steel 1.4571				
Main valve						
<b>Internal parts material</b>	Brass, Aluminium, Stainless steel	Stainless steel 1.4305				
<b>Seal materials</b>	FKM, NBR	FKM, NBR, FPM				
<b>Pneumatic connection</b>	Threaded port G1/4 or NAMUR-Flange NPT connector on request					
<b>Electrical connection</b>	Tag connector acc. to DIN EN 17301-803 Form A for cable pug Type 2508					
<b>Voltage tolerance</b>	±10%					
<b>Media</b>	compressed air acc. to ISO 8573-1 class 1-5					
<b>Media temperature</b>	-30 to + 80° C	-30 to + 80° C				
<b>Ambient temperature</b>	-40 to + 75° C	-30 to + 75° C				
<b>Type of protection</b>	with cable plug IP 65					
<b>Standard</b>	II 2G EEx ia IIC T5/T6 PTB 01 ATEX 2101 II 2D Ex ia D21 T 80° C					
<b>Response times</b>	5/2	5/2-bi.	5/3	3/2	5/2	5/2-bi.
opening	16ms	18ms	16ms	13ms	12ms	14ms
closing	27ms	18ms	22ms	47ms	74ms	14ms

**Note**

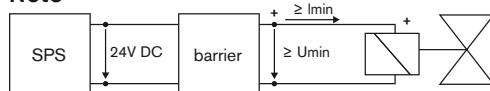

These units may only be used in explosive atmospheres in the manner approved by the Federal Institute of Physics and Technology (PTB), i.e., the permissible maximum electrical values must be complied with. Suitable barriers and isolating modules are available for this.

The valve is intended for operation on 24 VDC outputs via the intermediate switching of a corresponding intrinsically-safe operating resource (isolating module or barrier).

**Ordering chart valves in aluminium with manual override (without manual override on request)**

All products come with a standard stainless steel cap nut. This cap nut protects the exhaust channel from penetrating humidity.

Circuit function	Orifice [mm]	Seal material body	Port connection threaded port	Qn-value air [l/min]	Pressure range [bar]	Mass [g]	Nominal power [W]	Voltage/frequency [V/Hz]	Minimum terminal Voltage [V]	Item no.
<b>5/2 circuit function H</b>	9,0	FKM, NBR	G 1/4	1800	2,5-10	825	29	310	9	231 452
							23	481	11	231 453
<b>5/2-bistable circuit function H</b>	9,0	FKM, NBR	G 1/4	2100	2,5-10	1280	29	310	9	231 454
							23	481	11	231 455
<b>5/3 circuit function L</b>	9,0	FKM, NBR	G 1/4	1500	2,5-10	1350	29	310	9	231 456
							23	481	11	231 457
<b>5/3 circuit function N</b>	9,0	FKM, NBR	G 1/4	1500	2,5-10	1350	29	310	9	231 458
							23	481	11	231 459

**6519**  
for extended  
temperature range

**bürkert**

**Ordering chart valves in stainless steel with manual override (without manual override on request)**

All products come with a standard stainless steel cap nut. This cap nut protects the exhaust channel from penetrating humidity.

Circuit function	Orifice [mm]	Seal material body	Port connection threaded port	Q <sub>N</sub> -value air [l/min]	Pressure range [bar]	Mass [g]	Nominal power [W]	Voltage/frequency [V/Hz]	Minimum terminal Voltage [V]	Item no.
<b>5/2 circuit function H</b>	8,0	FKM, NBR	G 1/4	1980	3-10	1520	29	310	9	231 460
							23	481	11	231 461
<b>5/2-bistable circuit function H</b>	8,0	FKM, NBR	G 1/4	1920	3-10	1970	29	310	9	231 463
							23	481	11	231 464
<b>5/3 circuit function L</b>	8,0	FKM, NBR	G 1/4	1770	3-10	1970	29	310	9	231 465
							23	481	11	231 466
<b>5/3 circuit function N</b>	8,0	FKM, NBR	G 1/4	1770	3-10	1970	29	310	9	231 467
							23	481	11	231 468

**6519**  
for extended  
temperature range

**bürkert**

**Type 6519 for extended temperature range NAMUR standard**



Technical Data	Aluminium	Stainless steel
<b>Orifice [mm]</b>	9	8
Body material Pilot valve Main valve	Stainless steel Aluminium, ematal coated	Stainless steel Stainless steel 1.4571
<b>Internal parts material</b>	Brass, Aluminium, Stainless steel	Stainless steel 1.4305
<b>Seal materials</b>	FKM, NBR	FKM, NBR, FPM
<b>Pneumatic connection</b>	Threaded port G1/4 or NAMUR-Flange NPT connector on request	
<b>Electrical connection</b>	Tag connector acc. to DIN EN 17301-803	
<b>Power supply</b>	24 V DC 24/110/230 V/UC	
<b>Voltage tolerance</b>	±10%	
<b>Electr. power consumption</b>	2 W (Continuous operation, 100% ED)	
<b>Media</b>	compressed air acc. to ISO 8573-1 class 1-5	
<b>Media temperature</b>	-30 to + 80° C	-30 to + 80° C
<b>Ambient temperature</b>	-40 to + 80° C	-30 to + 80° C
<b>Type of protection</b>	with cable plug IP 65	
<b>Response times</b>	3/2 5/2 5/2-bi.	3/2 5/2 5/2-bi.
opening	13ms 16ms 14ms	13ms 12ms 14ms
closing	16ms 18ms 14ms	47ms 74ms 14ms

**Ordering chart valves in aluminium with manual override (without manual override on request)**

All products come with a standard stainless steel cap nut. This cap nut protects the exhaust channel from penetrating humidity.

Circuit function	Orifice [mm]	Seal material body	Port connection threaded port	Q <sub>N</sub> -value air [l/min]	Pressure range [bar]	Mass [g]	Nominal power [W]	Voltage/frequency [V/Hz]	Item no.
<b>3/2 circuit function C</b>	6,0	FKM, NBR	G 1/4	780	3-10	540	2	024/DC	231 469
								024/50-60	231 470
								110/50-60	231 471
								230/50-60	231 472
<b>5/2 circuit function H</b>	6,0	FKM, NBR	G 1/4	800	3-10	540	2	024/DC	231 473
								024/50-60	231 474
								110/50-60	231 475
								230/50-60	231 476
<b>5/2-bistable circuit function H</b>	6,0	FKM, NBR	G 1/4	900	3-10	540	2	024/DC	231 477
								024/50-60	231 478
								110/50-60	231 479
								230/50-60	231 480



**6519**  
for extended  
temperature range

**bürkert**

**Ordering chart valves in stainless steel with manual override (without manual override on request)**

All products come with a standard stainless steel cap nut. This cap nut protects the exhaust channel from penetrating humidity.

Circuit function	Orifice [mm]	Seal material body	Port connection threaded port	Q <sub>Nn</sub> -value air [l/min]	Pressure range [bar]	Mass [g]	Nominal power [W]	Voltage/frequency [V/Hz]	Item no.
<b>3/2 circuit function C</b>	6,0	FKM, NBR	G 1/4	1280	3-10	540	2	024/DC	231 481
								024/50-60	231 482
								110/50-60	231 483
								230/50-60	231 484
<b>5/2 circuit function H</b>	6,0	FKM, NBR	G 1/4	1060	3-10	540	2	024/DC	231 485
								024/50-60	231 486
								110/50-60	231 487
								230/50-60	231 488
<b>5/2-bistable circuit function H</b>	6,0	FKM, NBR	G 1/4	1050	3-10	540	2	024/DC	231 489
								024/50-60	231 490
								110/50-60	231 491
								230/50-60	231 492

**6519**  
for extended  
temperature range

**bürkert**



**Type 6519 for extended temperature range NAMUR Ex-m**



Technical Data	Aluminium	Stainless steel
<b>Orifice [mm]</b>	9	8
<b>Body material</b>	Pilot valve Aluminium, ematal coated	Stainless steel Stainless steel 1.4571
<b>Internal parts material</b>	Brass, Aluminium, Stainless steel	Stainless steel 1.4305
<b>Seal materials</b>	FKM, NBR	FKM, NBR, FPM
<b>Pneumatic connection</b>	Threaded port G1/4 or NAMUR-Flange NPT connector on request	
<b>Electrical connection</b>	Moulded cable, 3 m (non-detachable), Terminal box on request	
<b>Power supply</b>	24/110/230 V/UC	
<b>Voltage tolerance</b>	±10%	
<b>Electr. power consumption</b>	3 W (Continuous operation, 100% ED)	
<b>Media</b>	compressed air acc. to ISO 8573-1 class 1-5	
<b>Media temperature</b>	-30 to + 80° C	-30 to + 80° C
<b>Ambient temperature</b>	-40 to + 60° C	-30 to + 60° C
<b>Type of protection</b>	with cable plug IP 65	
<b>Approval</b>	PTB 00 ATEX 2129 X EX M II T4/T5/T6, II 2G, II 2D IP 65	
<b>Response times</b>	5/2	5/2
opening	16ms	13ms
closing	27ms	47ms

**Ordering chart valves in aluminium with manual override (without manual override on request)**

All products come with a standard stainless steel cap nut. This cap nut protects the exhaust channel from penetrating humidity.

Circuit function	Orifice [mm]	Seal material body	Port connection threaded port	QNn-value air [l/min]	Pressure range [bar]	Mass [g]	Nominal power [W]	Voltage/frequency [V/Hz]	Item no.
<b>3/2 circuit function C</b>	6,0	FKM, NBR	G 1/4	780	3-10	540	3	024/UC	231 494
								110/UC	231 495
								230/UC	231 496
<b>5/2 circuit function H</b>	6,0	FKM, NBR	G 1/4	800	3-10	540	3	024/UC	231 498
								110/UC	231 499
								230/UC	231 500
<b>5/2-bistable circuit function H</b>	6,0	FKM, NBR	G 1/4	900	3-10	540	3	024/UC	231 502
								110/UC	231 504
								230/UC	231 505

**Ordering chart valves in stainless steel with manual override (without manual override on request)**

All products come with a standard stainless steel cap nut. This cap nut protects the exhaust channel from penetrating humidity.

Circuit function	Orifice [mm]	Seal material body	Port connection threaded port	QNn-value air [l/min]	Pressure range [bar]	Mass [g]	Nominal power [W]	Voltage/frequency [V/Hz]	Item no.
<b>3/2 circuit function C</b>	6,0	FKM, NBR	G 1/4	1280	3-10	960	3	024/UC	231 508
								110/UC	231 509
								230/UC	231 510
<b>5/2 circuit function H</b>	6,0	FKM, NBR	G 1/4	1060	3-10	960	3	024/UC	231 512
								110/UC	231 513
								230/UC	231 515
<b>5/2-bistable circuit function H</b>	6,0	FKM, NBR	G 1/4	1050	3-10	1260	3	024/UC	231 517
								110/UC	231 518
								230/UC	231 519

**6519**  
for extended  
temperature range

**bürkert**



**Type 6519 for extended temperature range NAMUR Ex-i**



Technical Data	Aluminium	Stainless steel				
Orifice [mm]	9	8				
Body material	stainless steel	stainless steel				
Pilot valve	Aluminium, ematal coated	stainless steel 1.4571				
Main valve						
Internal parts material	Brass, aluminium, stainless steel	Stainless steel 1.4305				
Seal materials	FKM, NBR	FKM, NBR, FPM				
Pneumatic connection	Threaded port G1/4 or NAMUR-Flange NPT connector on request					
Electrical connection	Tag connector acc. to DIN EN 17301-803 Form A for cable pug Type 2508					
Voltage tolerance	±10%					
Media	compressed air acc. to ISO 8573-1 class 1-5					
Media temperature	-30 to + 80° C	-30 to + 80° C				
Ambient temperature	-40 to + 75° C	-30 to + 75° C				
Type of protection	with cable plug IP 65					
Approval	II 2G EEx ia IIC T5/T6 PTB 01 ATEX 2101 II 2D Ex ia D21 T 80° C					
Response times	5/2	5/2-bi.	5/3	3/2	5/2	5/2-bi.
opening	16ms	18ms	16ms	13ms	12ms	14ms
closing	27ms	18ms	22ms	47ms	74ms	14ms

**Note**

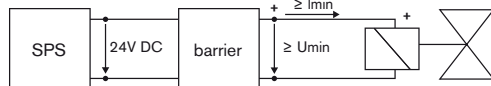

These units may only be used in explosive atmospheres in the manner approved by the Federal Institute of Physics and Technology (PTB), i.e., the permissible maximum electrical values must be complied with. Suitable barriers and isolating modules are available for this.

The valve is intended for operation on 24 VDC outputs via the intermediate switching of a corresponding intrinsically-safe operating resource (isolating module or barrier).

**Ordering chart valves in aluminium with manual override (without manual override on request)**

All products come with a standard stainless steel cap nut. This cap nut protects the exhaust channel from penetrating humidity.

Circuit function	Orifice [mm]	Seal material body	Port connection threaded port	QNn-value air [l/min]	Pressure range [bar]	Mass [g]	Minimum switching current [mA]	Nominal resistance of the coil [Ohm]	Minimum terminal voltage [V]	Item no.
3/2 circuit function C	6,0	FKM, NBR	G 1/4	780	3-10	690	29	310	9	231 520
							23	481	11	231 521
5/2 circuit function H	6,0	FKM, NBR	G 1/4	800	3-10	690	29	310	9	231 522
							23	481	11	231 523
5/2-bistable circuit function H	6,0	FKM, NBR	G 1/4	900	3-10	1140	29	310	9	231 524
							23	481	11	231 525

**Ordering chart valves in stainless steel with manual override (without manual override on request)**

All products come with a standard stainless steel cap nut. This cap nut protects the exhaust channel from penetrating humidity.

Circuit function	Orifice [mm]	Seal material body	Port connection threaded port	QNn-value air [l/min]	Pressure range [bar]	Mass [g]	Minimum switching current [mA]	Nominal resistance of the coil [Ohm]	Minimum terminal voltage [V]	Item no.
3/2 circuit function C	6,0	FKM, NBR	G 1/4	1280	3-10	1100	29	310	9	231 526
							23	481	11	231 527
5/2 circuit function H	6,0	FKM, NBR	G 1/4	1060	3-10	1100	29	310	9	231 528
							23	481	11	231 529
5/2-bistable circuit function H	6,0	FKM, NBR	G 1/4	1050	3-10	1550	29	310	9	231 530
							23	481	11	231 531

**6519**  
for extended  
temperature range

**Accessories**

**Cable Plug 2508 acc. to DIN EN 175301-803 Form A**

Included in delivery is a connector with flat seal and fixing screw.

For other cable plug versions acc. to DIN EN 175301-803 Form A (previously DIN 43650) with integrated circuitry, see datasheet Type 2508.

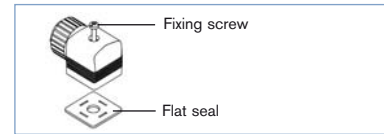

**Dimensions Type 2508 [mm]**

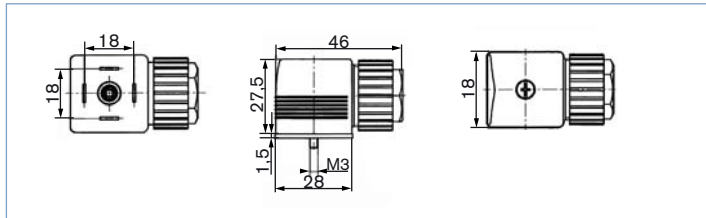

**Ordering chart cable plug Type 2508**

Circuit	Voltage	Item no.
<b>For standard version 6519 fixing screw in steel</b> (galvanised and chrome-plated)		
None (standard)	0- 250V	008 376
with LED	12- 24V	008 360
with LED and varistor	12- 24V	008 367
with LED and varistor	200- 240V	008 369
<b>For Ex i version 6519</b> Fixing screw in stainless steel 1.4404 and blue compression gland nut		
without circuitry	0- 250V	438 574
for further versions see datasheet 2508		

**Ordering chart further Accessories**

Accessories	Features	Item no.
Cap nut 	Cap nut in stainless steel for additional protection of the exhaust channel from penetrating humidity,	649 554
Blanking plug	G 1/4	780 142
Silencer	G 1/4	005 064
Labelling plate	64 pieces	635 416

**Semi-delay fuse for 6519 NAMUR Ex m**

Voltage [V]	Max. current [mA]	Item no.
24 V	315 mA	153 733
110 V	50 mA	153 716
230 V	32 mA	153 715

Dimensions [mm]

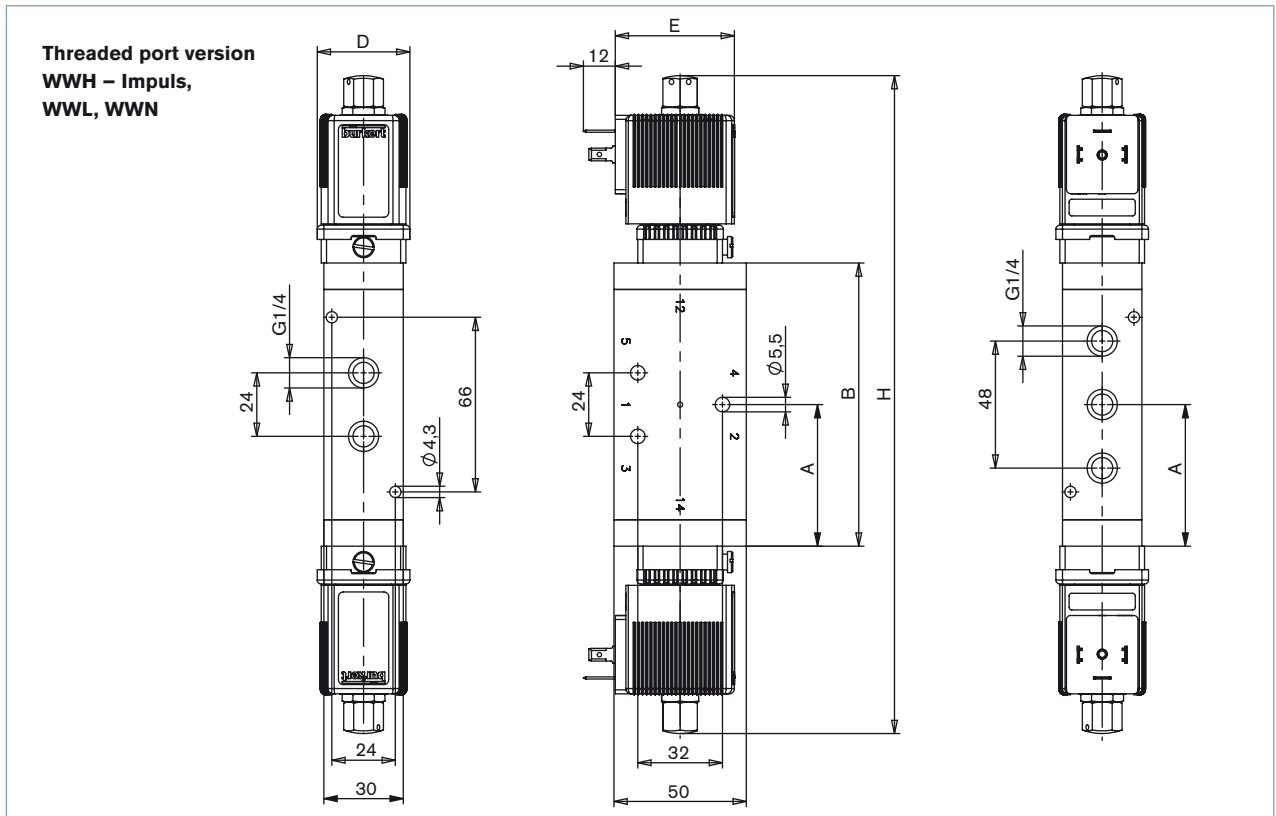
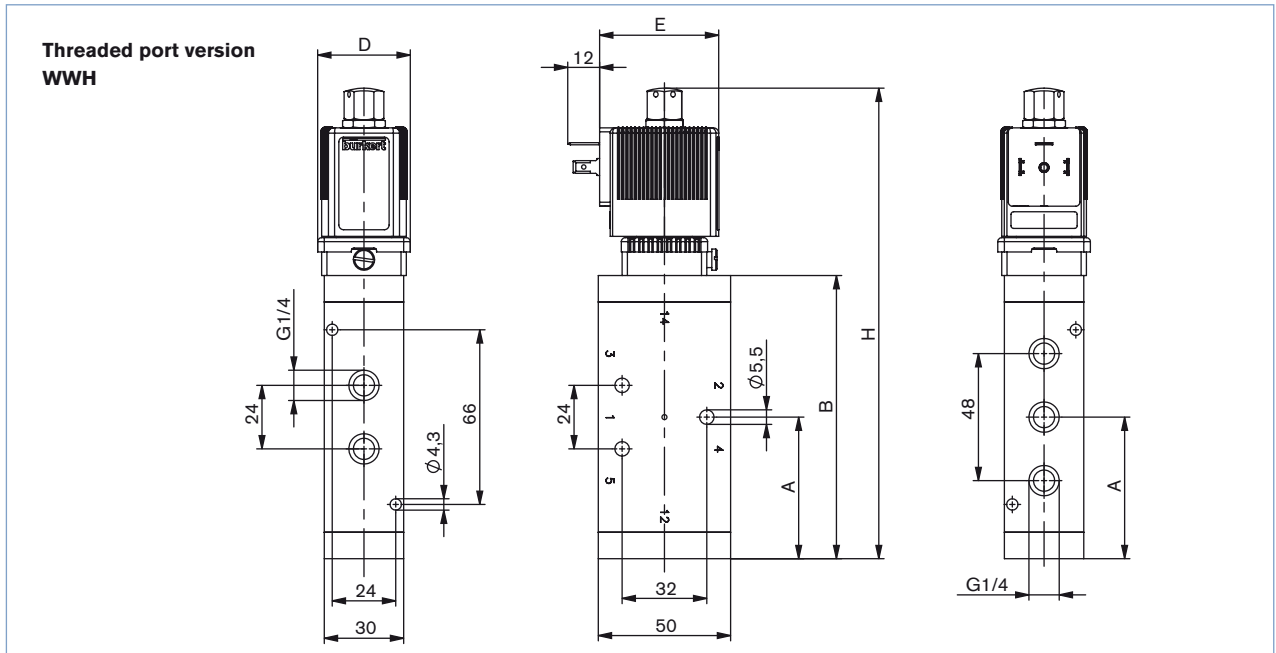

Version	Variation	A	B	D		E		H	
				Standard, Exm	Exi	Standard, Exm	Exi	Standard, Exm	Exi
WWH	Stainless steel	53,5	107	35	40,7	45	51	177,8	186,6
WWH	Aluminium	43,5	97	35	40,7	45	51	167,8	176,6
WWH – Impuls, WWL, WWN	Stainless steel	53,5	107	35	40,7	45	51	248,6	266,2
WWH – Impuls, WWL, WWN	Aluminium	53,5	107	35	40,7	45	51	148,6	266,2

**6519**  
for extended  
temperature range

**bürkert**

**Dimensions [mm]**

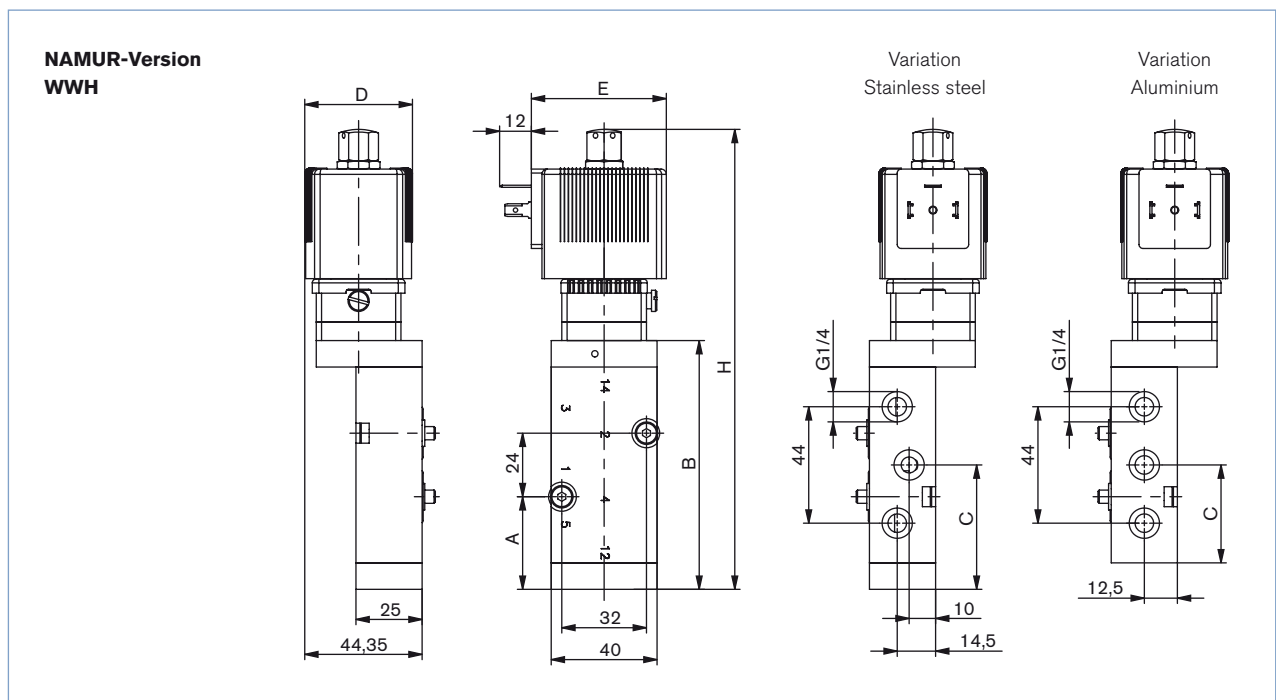
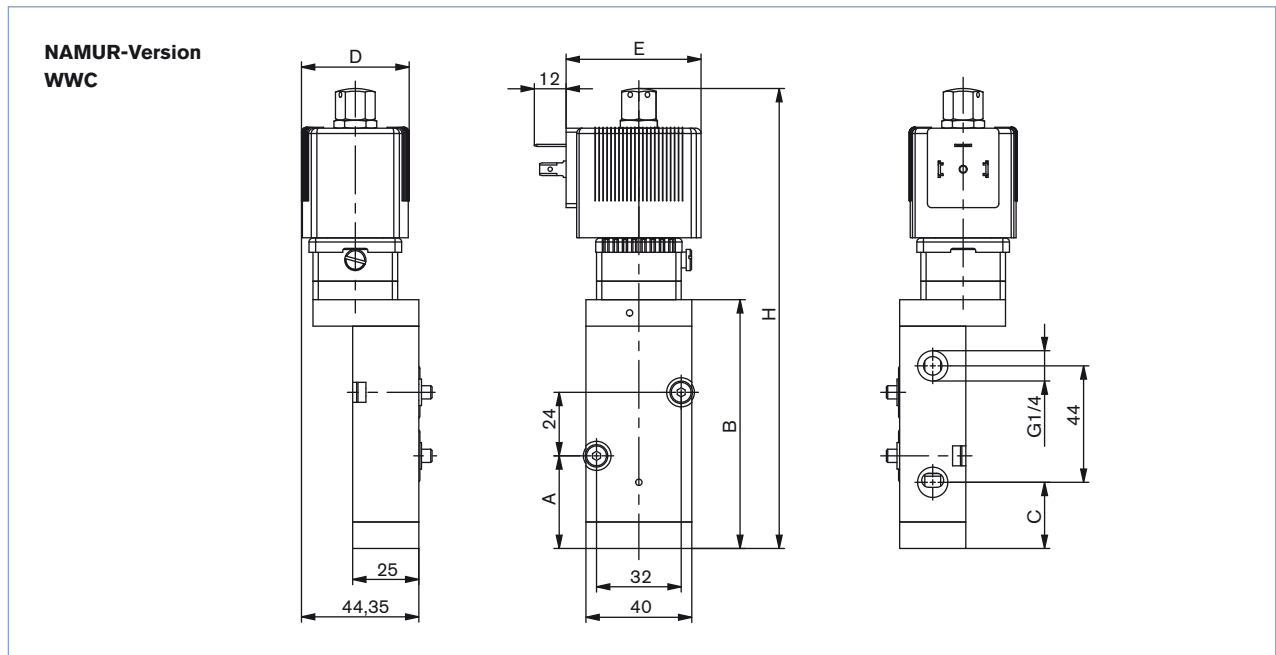

Version	Variation	A	B	C	D		E		H	
					Standard, Exm	Exi	Standard, Exm	Exi	Standard, Exm	Exi
WWC	Stainless steel	35	94	25	35	40,7	45	51	165	173,8
WWC	Aluminium	25	84	15	35	40,7	45	51	155	163,8
WWH	Stainless steel	35	94	47	35	40,7	45	51	165	173,8
WWH	Aluminium	25	84	37	35	40,7	45	51	155	163,8
WWH – Impuls, WWL, WWN	Stainless steel	35	94	47	35	40,7	45	51	236	253,6
WWH – Impuls, WWL, WWN	Aluminium	35	94	47	35	40,7	45	51	236	253,6

**6519**  
for extended  
temperature range

**Dimensions [mm]**

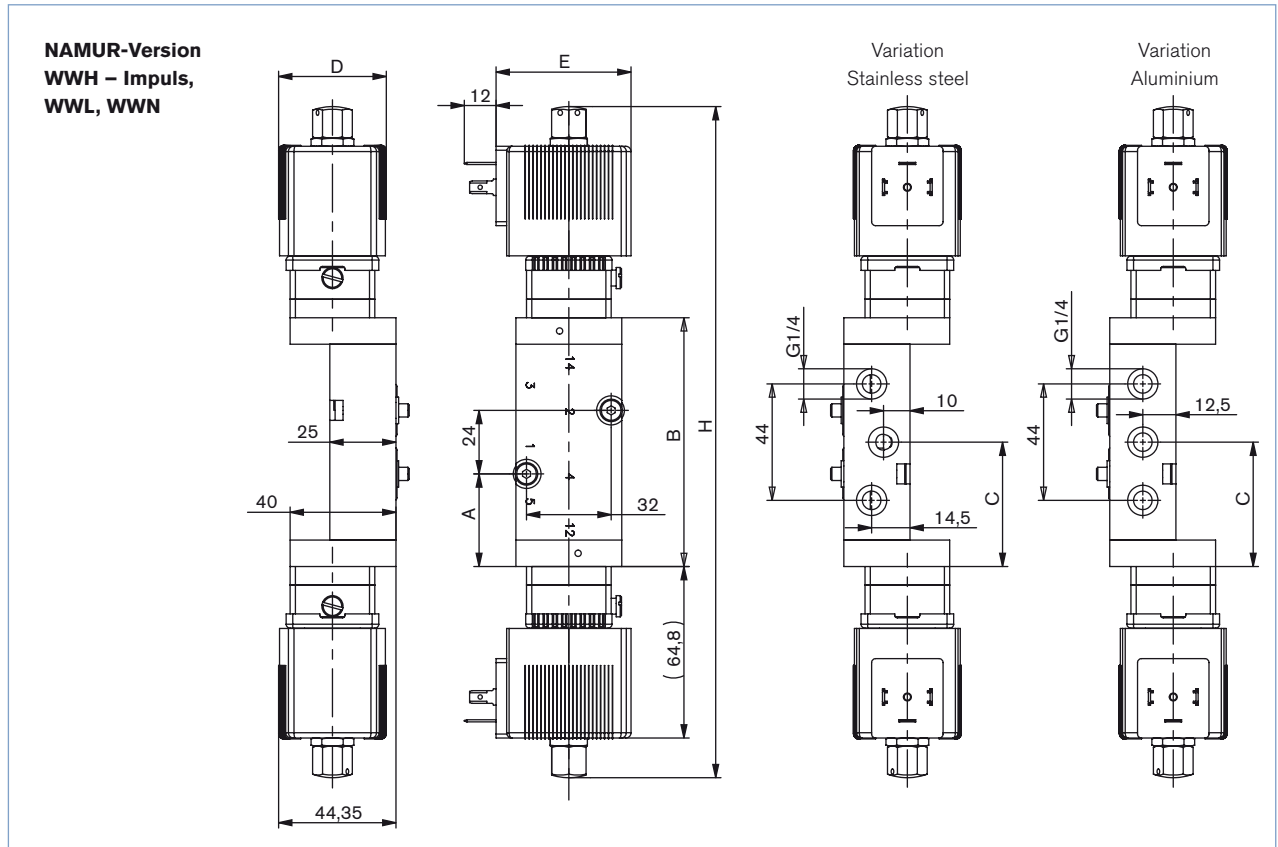

Version	Variation	A	B	C	D		E		H	
					Standard, Exm	Exi	Standard, Exm	Exi	Standard, Exm	Exi
WWC	Stainless steel	35	94	25	35	40,7	45	51	165	173,8
WWC	Aluminium	25	84	15	35	40,7	45	51	155	163,8
WWH	Stainless steel	35	94	47	35	40,7	45	51	165	173,8
WWH	Aluminium	25	84	37	35	40,7	45	51	155	163,8
WWH – Impuls, WWL, WWN	Stainless steel	35	94	47	35	40,7	45	51	236	253,6
WWH – Impuls, WWL, WWN	Aluminium	35	94	47	35	40,7	45	51	236	253,6