

## 2/2-way Miniature Solenoid Valve



Type 6011 can be combined with...



### Type 2506

Cable plug to  
DIN EN 175301-803\*  
form C



### Type 2507

Cable plug industrial  
standard form B

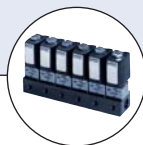

### Type 6012

Multiple manifold  
(e.g. 6-fold)

- Direct-acting
- 0 ... 21 bar <sup>1)</sup>
- DN 1.2 ... 2.4 mm
- M5, G1/8 and sub-base
- 21 mm coil spacing when mounted on manifold

This direct-acting 2/2-way miniature solenoid valve is available in two versions.

### Standard version:

Type 6011 is a miniature solenoid valve used for shut-off, dosing, filling, ventilating and for technical vacuum. It is of modular design and may be mounted individually or as a block on a multiple manifold.

### Analysis and vacuum technology:

Type 6011 A is a high-quality miniature solenoid valve for analysis and vacuum technology. It is manufactured under clean-room conditions. This includes thorough cleaning of all parts in contact with media from organic and inorganic substances. The limit for residual hydrocarbons is below 0.2 mg/dm<sup>3</sup>. 100 % of the valves are subjected to a special leakage test with regard to tight seating and tightness to the exterior. The permissible leakage rate is 10<sup>-4</sup> mbar l/s. The valve is used for shut-off, dosing, filling, ventilating and particularly for analysis technology.

### Circuit function A

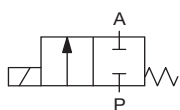

2/2-way valve,  
normally closed by  
spring force

Technical data	
<b>Body material</b>	
Type 6011	brass, polyamide (PA), stainless steel 1.4305
Type 6011 A	brass, stainless steel 1.4305
<b>Sealing material</b>	FKM
<b>Analytical version (Typ 6011 A)</b>	version free from silicones, oil and grease leaktightness better than 10 <sup>-4</sup> mbar l/s
<b>Limit value for remainder carbon (Type 6011 A)</b>	<0,2 mg/dm <sup>3</sup>
<b>Medium</b>	
Type 6011	<ul style="list-style-type: none"> <li>▪ technical vacuum</li> <li>▪ neutral gases and fluids (e.g. compressed air, water hydraulic oil</li> <li>▪ neutral/aggressive media that do not attack the body and seal materials</li> </ul>
Type 6011 A	
<b>Medium temperature</b>	-10 ... +100 °C
<b>Ambient temperature</b>	max. +55 °C
<b>Viscosity</b>	max. 21 mm <sup>2</sup> /s
<b>Port connection</b>	
Type 6011	M5, G1/8, sub-base
Type 6011 A	G1/8, sub-base
<b>Betriebsspannung</b>	
Typ 6011	24 V DC, 24 V/50 Hz, 110 / 230 V / 50 Hz
Typ 6011 A	24 V DC, 230 V / 50 Hz
<b>Voltage tolerance</b>	± 10%
<b>Duty cycle/single valve</b>	
when mounted as a block on a manifold	100 % continuous rating Intermittent operation 60 % (30 min) or with 2 W coil (on request)
<b>Electrical connection</b>	<ul style="list-style-type: none"> <li>▪ to DIN EN 175301-803* Form C for cable plug Type 2506 (see Ordering chart for Accessories)</li> <li>▪ Form B (industrial standard) for Type 2507 (see Ordering chart for Accessories)</li> </ul>
<b>Installation</b>	as required, preferably with actuator upright
<b>Assembly</b>	no oil, grease or silicones to be used as installation aids
<b>Mass</b>	ca. 125 g
<b>Protection class</b>	IP65 with cable plug

<sup>1)</sup> Pressure data [bar]: Overpressure with respect to atmospheric pressure

\* previously DIN 43650

## Response times

Orifice [mm]	K <sub>v</sub> value water [m <sup>3</sup> /h]	Pressure range		Coil power [W]	Power consumption			Response times		
		for AC [bar]	for DC [bar]		Inrush AC [VA]	Hold AC (hot coil) [VA]	DC (hot/cold coil) [W]	Opening [ms]	Closing [ms]	
1.2	0.045	0-21	0-12	4 W	9	6	4	4/5.5	7-10	10-15
1.6	0.06	0-12	0-6	4 W	9	6	4	4/5.5	7-10	10-15
2.0	0.11	0-8	0-4.5	4 W	9	6	4	4/5.5	7-12	7-12
2.4	0.13	0-6	0-3	4 W	9	6	4	4/5.5	7-12	7-12

<sup>1)</sup> Pressure data [bar]: Overpressure with respect to atmospheric pressure

- k<sub>v</sub> value [m<sup>3</sup>/h]: Flow rate value for water, measured at +20 °C and 1 bar<sup>1)</sup> pressure differential over a fully opened valve.
- Response times [ms]: measured at valve outlet at 6 bar<sup>1)</sup> and +20 °C  
Opening: pressure build-up 0 ... 90 %, closing: pressure relief 100 ... 10 %

## Material

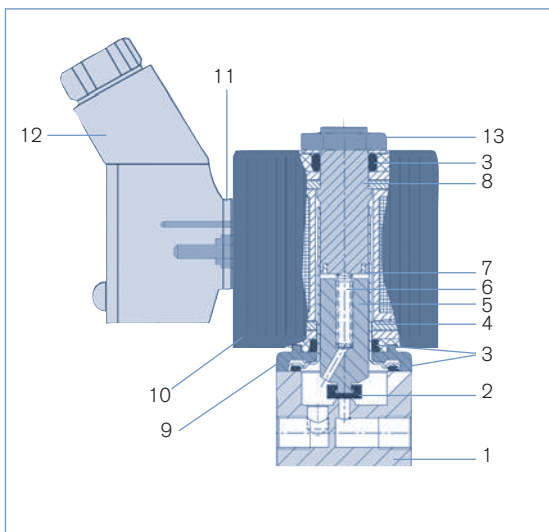

1	Body	Brass, stainless steel 1.4305 PA (polyamide)
2	Armature seal	FKM
3	O-ring	FKM
4	Guide tube	Stainless steel 1.4303
5	Core	Stainless steel 1.4105
6	Spring	Stainless steel 1.4310
7	Shading ring	Copper, Silver
8	Stopper	Stainless steel 1.4105
9	Sub-base	Thick-film passivated (brass version) nickel-plated surface (stainless steel version)
10	Coil DIN EN 175301-803* form C Form B (industr. standard)	PA Epoxy
11	Flat seal	NBR
12	Cable plug	PA
13	Locknut	Thick-film passivated

<sup>\*)</sup> bisher DIN 43650

## Dimensions [mm]

### Multiple manifold

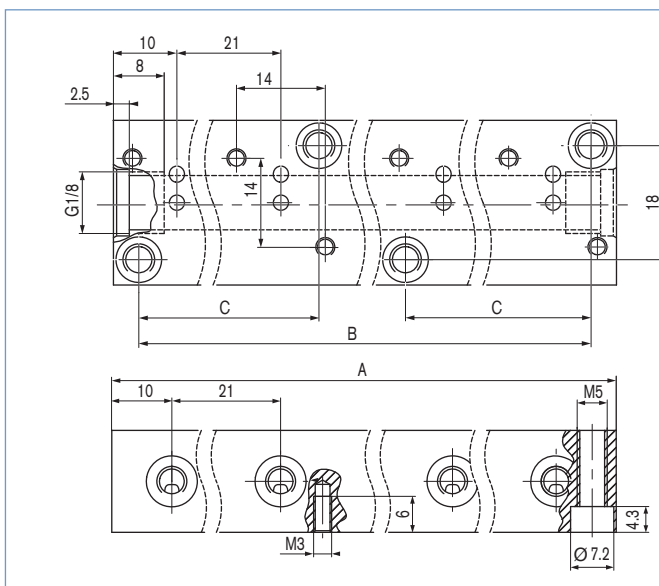

No. of valves	A [mm]	B [mm]	C [mm]
1	20	12	-
2	41	33	-
3	62	54	-
4	83	75	-
5	104	96	-
6	125	117	-
7	146	138	-
8	167	159	54
9	188	180	54
10	209	201	75
11	230	222	75
12	251	243	96

Dimensions [mm]

Single manifold

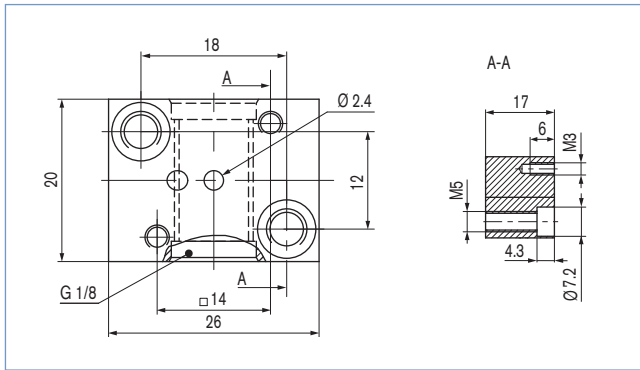

Type 6011 / 6011 A  
Version with electrical coil connection  
to DIN EN 175301-803\* form C  
(cable plug type 2506)

Type 6011 / 6011 A  
Version with electrical coil connection  
Form B industrial standard  
(cable plug type 2507)

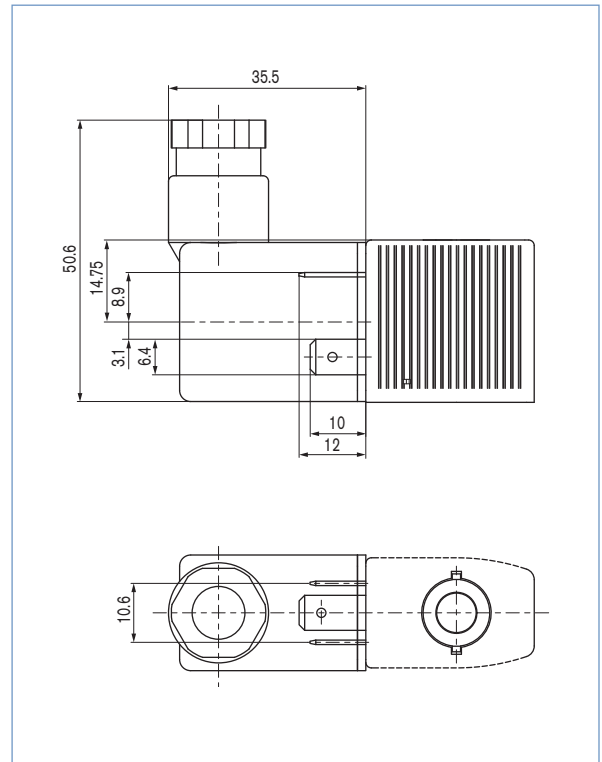
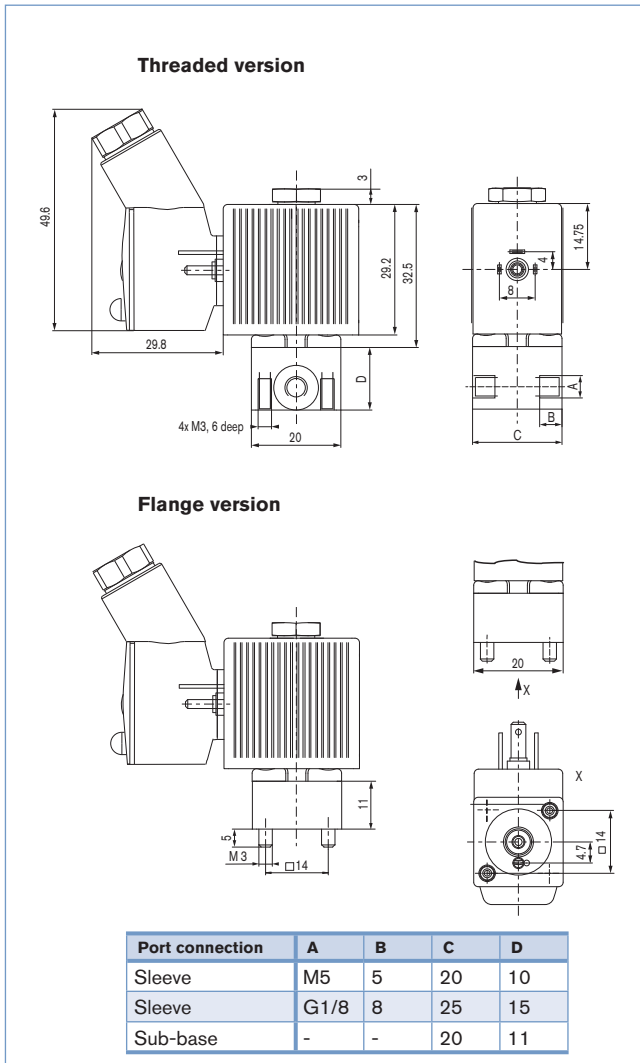

\* previously DIN 43650

## Ordering chart

## Type 6011

Solenoid valve complete in ported or flanged version with electrical coil connection to DIN EN 175301-803\* Form C for cable plug Type 2506

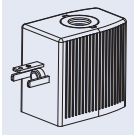

- All valves complete with coil and FKM seal material; without cable plug
- Other versions on request.

Circuit function	Orifice [mm]	Port connection	Kv value water [m <sup>3</sup> /h]	Pressure range [bar] <sup>1)</sup>	Voltage/Frequency [V/Hz]	Item no. Brass body	Item no. Stainless steel body
A 	1.2	M5	0.045	0-12	24/DC	134 084	-
				0-21	24/50	134 085	-
				0-21	110/50	134 086	-
				0-21	230/50	134 087	-
	1.6	M5	0.06	0-6	24/DC	134 088	-
				0-12	24/50	134 089	-
				0-12	110/50	134 090	-
				0-12	230/50	134 091	-
		G1/8	0.06	0-6	24/DC	134 071	134 103
				0-12	24/50	134 092	134 104
				0-12	110/50	134 093	134 105
				0-12	230/50	134 094	134 106
	2.0	G1/8	0.11	0-4.5	24/DC	134 095	134 107
				0-8	24/50	134 096	134 108
				0-8	110/50	134 097	134 109
				0-8	230/50	134 098	134 110
	2.4	G1/8	0.13	0-3	24/DC	134 099	134 111
				0-6	24/50	134 100	134 112
				0-6	110/50	134 101	134 113
				0-6	230/50	134 102	134 114
	1.2	sub-base	0.045	0-12	24/DC	134 115	-
				0-21	24/50	134 116	-
				0-21	110/50	134 117	-
				0-21	230/50	134 118	-
	1.6	sub-base	0.06	0-6	24/DC	134 119	134 131
				0-12	24/50	134 120	134 132
				0-12	110/50	134 121	134 133
				0-12	230/50	134 122	134 134
2.0	sub-base	0.11	0-4.5	24/DC	134 123	134 135	
			0-8	24/50	134 124	134 136	
			0-8	110/50	134 125	134 137	
			0-8	230/50	134 126	134 138	
2.4	sub-base	0.13	0-3	24/DC	134 127	-	
			0-6	24/50	134 128	-	
			0-6	110/50	134 129	-	
			0-6	230/50	134 130	-	

<sup>1)</sup> Pressure data [bar]: Overpressure with respect to atmospheric pressure

<sup>\*)</sup> previously DIN 43650

## Ordering chart

## Type 6011 A

Solenoid valve complete in threaded or flanged version with electrical coil connection to DIN EN 175301-803\* Form C for cable plug Type 2506

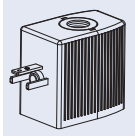

- All valves complete with coil (4 W) and FKM seal material; without cable plug
- Other versions on request.

Circuit function	Orifice [mm]	Port connection	Kv value water [m <sup>3</sup> /h]	Pressure range [bar] <sup>1)</sup>	Voltage/Frequency [V/Hz]	Item no. Brass body	Item no. Stainless steel body
A 	1.6	G1/8	0.06	0-6	24/DC	137 794	137 800
				0-12	230/50	137 795	137 801
	2.0	G1/8	0.11	0-4.5	24/DC	137 796	137 802
				0-8	230/50	137 797	137 803
	2.4	G1/8	0.13	0-3	24/DC	137 798	137 804
				0-6	230/50	137 799	137 805
	1.2	sub-base	0.045	0-12	24/DC	137 806	137 812
				0-21	230/50	137 807	137 813
	1.6	sub-base	0.06	0-6	24/DC	137 808	137 814
				0-12	230/50	137 809	137 815
2.0	sub-base	0.11	0-4.5	24/DC	137 810	137 816	
			0-8	230/50	137 811	137 817	

<sup>1)</sup> Pressure data [bar]: Overpressure with respect to atmospheric pressure

<sup>\*)</sup> previously DIN 43650

## Ordering chart

## Type 6011

Solenoid valve complete in ported or flanged version with electrical coil connection Form B (industrial standard) for cable plug Type 2507

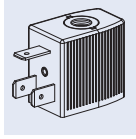

- All valves complete with coil and FKM seal material; without cable plug
- Other versions on request.

Circuit function	Orifice [mm]	Port connection	Kv value water [m <sup>3</sup> /h]	Pressure range [bar] <sup>1)</sup>	Voltage/Frequency [V/Hz]	Item no. Brass body	Item no. Stainless steel body
A 	1.2	M5	0.045	0-12	24/DC	163 491	-
				0-21	24/50	163 492	-
				0-21	110/50	163 493	-
				0-21	230/50	163 494	-
	1.6	M5	0.06	0-6	24/DC	163 495	-
				0-12	24/50	163 496	-
				0-12	110/50	163 497	-
				0-12	230/50	163 498	-
		G1/8	0.06	0-6	24/DC	163 499	163 509
				0-12	24/50	163 500	163 510
				0-12	110/50	163 501	163 511
				0-12	230/50	163 502	163 512
	2.0	G1/8	0.11	0-4.5	24/DC	163 503	163 513
				0-8	24/50	163 504	163 514
				0-8	110/50	163 505	163 515
				0-8	230/50	163 506	163 516
	2.4	G1/8	0.13	0-3	24/DC	161 193	163 517
				0-6	24/50	163 507	163 518
				0-6	110/50	163 508	163 519
				0-6	230/50	161 194	163 520
	1.2	sub-base	0.045	0-12	24/DC	163 521	-
				0-21	24/50	163 522	-
				0-21	110/50	163 523	-
				0-21	230/50	163 524	-
	1.6	sub-base	0.06	0-6	24/DC	163 525	163 537
				0-12	24/50	163 526	163 538
				0-12	110/50	163 527	163 539
				0-12	230/50	163 528	163 540
2.0	sub-base	0.11	0-4.5	24/DC	163 529	163 541	
			0-8	24/50	163 530	163 542	
			0-8	110/50	163 531	163 543	
			0-8	230/50	163 532	163 544	
2.4	sub-base	0.13	0-3	24/DC	163 533	-	
			0-6	24/50	163 534	-	
			0-6	110/50	163 535	-	
			0-6	230/50	163 536	-	

<sup>1)</sup> Pressure data [bar]: Overpressure with respect to atmospheric pressure

## Ordering chart

## Type 6011 A

Solenoid valve complete in threaded or flanged version with electrical coil connection Form B (industrial standard) for cable plug Type 2507

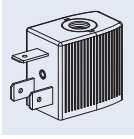

- All valves complete with coil (4 W) and FKM seal material; without cable plug
- Other versions on request.

Circuit function	Orifice [mm]	Port connection	Kv value water [m <sup>3</sup> /h]	Pressure range [bar] <sup>1)</sup>	Voltage/Frequency [V/Hz]	Item no. Brass body	Item no. Stainless steel body
A 	1.6	G1/8	0.06	0-6	24/DC	163 545	163 551
				0-12	230/50	163 546	163 552
	2.0	G1/8	0.11	0-4.5	24/DC	163 547	163 553
				0-8	230/50	163 548	163 554
	2.4	G1/8	0.13	0-3	24/DC	163 549	163 555
				0-6	230/50	163 550	163 556
	1.2	sub-base	0.045	0-12	24/DC	163 557	163 563
				0-21	230/50	163 558	163 564
	1.6	sub-base	0.06	0-6	24/DC	163 559	163 565
				0-12	230/50	163 560	163 566
	2.0	sub-base	0.11	0-4.5	24/DC	163 561	163 567
				0-8	230/50	163 562	163 568

<sup>1)</sup> Pressure data [bar]: Overpressure with respect to atmospheric pressure

## Ordering chart for accessories

## Manifolds

Material	No. of valves	Item no.
Aluminium anodized	1	005 312
	2	005 355
	3	005 313
	4	005 314
	5	005 315
	6	005 316
	7	005 893
	8	005 166
	9	005 241
	10	005 819
	11	005 242
	12	005 222

## Accessories for manifolds

Accessory	Features	Item no.
Blanking plug	with seal ring, G1/8	005 041
Cover plate	for unused valves	005 100

## Cable plug type 2506 to DIN EN 175301-803\* form C

	Circuitry	Voltage	Item no.
	None (standard)	0 - 250 V AC/DC	008 353
	with LED	12 - 24 V AC/DC	008 402
	with LED and varistor	12 - 24 V AC/DC	008 408
	with rectifier, LED and varistor	12 - 24 V AC/DC	008 354

- Supplied with cable plug; flat seal and fixing screw.
- Other versions of cable plug with circuitry to DIN EN 175301-803\* Form C (see Datasheet Type 2506).

<sup>\*)</sup> previously DIN 43650

## Cable plug type 2507 Form B (industrial standard)

	Circuitry	Voltage	Item no.
	None (standard)	2 - 250 V AC/DC	423 845
	with LED	24 V AC/DC	423 849
	with LED and freewheeling diode	12 - 24 V DC	423 851
	with rectifier, LED and varistor	12 - 24 V AC/DC	423 853

- Supplied with cable plug; flat seal and fixing screw.
- Other versions of cable plug with circuitry Form B (industrial standard) (see Datasheet Type 2507).