

Zero Deadleg T-Valve, manually operated, stainless steel block material, DN 8-50



- Fully integrated in Burkert's Process Control Systems
- Zero dead volume
- Monoblock – no welds
- Quality certifications FDA

Type 3234 can be combined with...



Type 8034
Flow meter

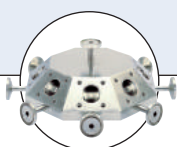

Multi-Port Block



Type 3233/2031
Tandem valve

The Burkert Zero Deadleg T Valve system is designed for control of ultra pure, sterile, aggressive or abrasive fluids. Enables especially optimal sampling, draining or diverting of critical process fluids. The valve body is machined from a single piece of block material (monoblock – no weld seam).

The high quality diaphragms separate hermetically critical fluids from the actuator. The manual actuator in PPS or stainless steel can be sterilized.

Applications

- Pharma
- Biotechnology
- Food Industry

Technical data

Body materials	<ul style="list-style-type: none"> ▪ Monoblock stainless steel ▪ 316 L/1.4435/BN2 Fe < 0.5%/C ≤ 0.03%
Actuator materials Actuator and bonnet	PPS, stainless steel 1.4581
Seal material	EPDM, PTFE/EPDM, advanced PTFE/EPDM
Media	Neutral gases and liquids, high purity, sterile, aggressive or abrasive
Viscosity	Up to viscous
Surface qualities (average roughness)	
Internal mechanical polished	Ra ≤ 0.5 µm (20 µlnch or 240 grit)
Internal electro polished	Ra ≤ 0.4 µm (16 µlnch or 280 grit)
Internal mirror finish ¹⁾	Ra ≤ 0.25 µm (10 µlnch or 330 grit)
Temperatures Media Ambient	-10°C to +130°C (briefly up to +150°C) +5°C to +140°C
Port connections Weld end acc. to	<ul style="list-style-type: none"> ▪ EN ISO 1127/ISO 4200 ▪ DIN 11850 Series 0 to 3 ▪ ASME BPE ▪ SMS 3008 ▪ BS 4825
Clamp acc. to	<ul style="list-style-type: none"> ▪ ISO 2852 ▪ ASME BPE ▪ DIN 32676
Installation	As required
Option (on request, not for DN 8/10)	Locking function

¹⁾ Internal Ra < 0.1 µm/4 µlnch/500 Grit: on request

Technical data, continued**Specifications**

Orifice diaphragm [mm]	Kv value water (m ³ /h)	Max. operating pressure (medium) for seal material EPDM and PTFE/EPDM [bar]
8	1.0	10
10	1.0	10
15	6.0	10
20	11.0	10
25	16.0	10
40	29.0	10
50	50.0	10 ¹⁾

¹⁾ Max. operating pressure 7 bar for bonnet and manual actuator in PPS

Orifice DN 65, DN 80 and DN 100 on request

► Various other Clamp and Sterile threaded end connection combination are available, please consult for advice.

Approvals/certifications

- Certification of Conformity for Raw Material EN-ISO 10204 3.1
- Attestation of compliance with the order EN-ISO 10204 2.1
- Test report EN-ISO 10204 2.2
- 3A Certification on request
- Certification of Conformity for Pickling and Electropolishing Processes
- Certification of Conformity for the Surface Quality DIN4762-DIN4768-ISO/4287/1
- Attestation of compliance with FDA CFR No. 21.177.1550 for PTFE/EPDM and advanced PTFE/EPDM and 21.177.2600 for EPDM
- USP CLASS VI certification for EPDM, PTFE and advanced PTFE diaphragm
- Test Certification and Conformity Certification for the Final Assembly of Diaphragm Valves
- ISO 9001 Certification

Note: Retrospective manufacturing certification for process diaphragm valves can not be made, therefore please notify when ordering.

Materials

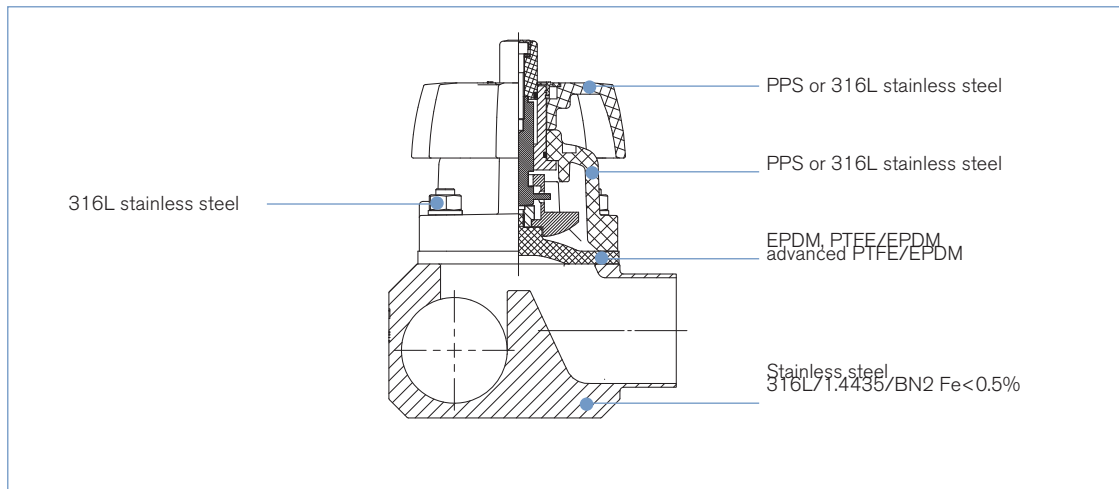

Example of available diaphragm materials

Developed to handle the unique challenges of hygienic and sterile applications, Bürkert offers diaphragms with precise material formula and physical tolerances. Bürkert diaphragms are available in a wide range of materials which have been proven in food & beverage, biotechnology, pharmaceutical and cosmetic industry applications. Diaphragms are tested during development and production to ensure reliability in critical processing environments.

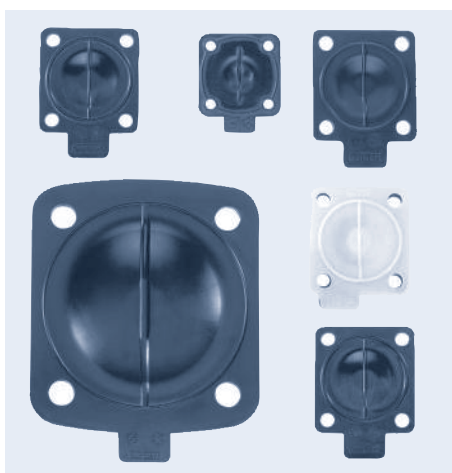

- EPDM (Ethylene Propylene Rubber)
- PTFE/EPDM
- Advanced PTFE/EPDM
- FKM
- PTFE/FKM
- NBR

Dimensions [mm]

Welded body acc. to EN ISO 1127/ISO 4200

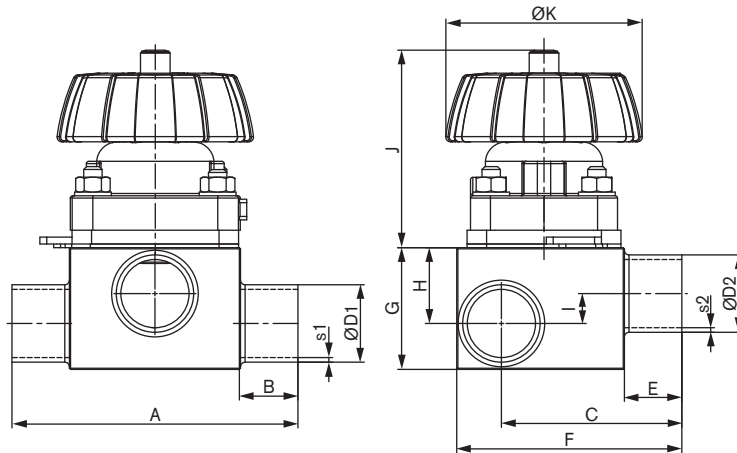

For all actuators

Orifice	J	ØK
8	48	34
15	77	85
20	84	85
25	86	85
40	105	114
50	120	114

Orifice	ØD1	s1	ØD2	s2	A	B	C	E	F	G	H	I
8	17.2	1.6	17.2	1.6	78.0	20	49.00	20	60	29	18	8.0
	21.3	1.6	17.2	1.6	78.0	20	51.05	20	64	34	21	11.0
	26.9	1.6	13.5	1.6	88.0	25	53.85	20	70	38	23	13.0
	33.7	2.0	13.5	1.6	88.0	25	56.85	20	76	45	26	16.0
	42.4	2.0	13.5	1.6	88.0	25	61.20	20	84	52	29	19.0
	42.4	2.0	17.2	1.6	88.0	25	61.20	20	84	52	29	19.0
15	48.3	2.0	13.5	1.6	88.0	25	64.15	20	90	57	31	21.0
	13.5	1.6	13.5	1.6	93.0	20	52.05	20	70	27	17	4.5
	17.2	1.6	13.5	1.6	93.0	20	53.90	20	70	31	18	4.5
	21.3	1.6	21.3	1.6	93.0	20	55.95	20	71	35	21	6.5
	26.9	1.6	21.3	1.6	103.0	25	58.75	20	78	42	25	11.5
	33.7	2.0	21.3	1.6	103.0	25	62.75	20	82	47	28	14.5
	42.4	2.0	21.3	1.6	103.0	25	67.10	20	91	56	32	18.5
	48.3	2.0	13.5	1.6	103.0	25	69.05	20	97	61	34	20.5
	48.3	2.0	21.3	1.6	103.0	25	69.05	20	97	63	35	21.5
	60.3	2.0	13.5	1.6	113.0	30	76.05	20	109	71	38	24.5
20	60.3	2.0	21.3	1.6	113.0	30	76.05	20	109	72	38	24.5
	76.1	2.0	13.5	1.6	113.0	30	83.95	20	125	85	44	30.5
	76.1	2.0	21.3	1.6	113.0	30	83.95	20	125	85	44	30.5
	88.9	2.3	13.5	1.6	113.0	30	90.05	20	140	99	52	38.5
	26.9	1.6	26.9	1.6	114.0	25	70.25	25	88	42	24	6.0
	33.7	2.0	26.9	1.6	114.0	25	73.25	25	94	48	28	10.0
	42.4	2.0	26.9	1.6	114.0	25	78.60	25	102	57	33	15.0
	48.3	2.0	26.9	1.6	114.0	25	80.55	25	108	63	35	17.0
25	60.3	2.0	26.9	1.6	124.0	30	86.55	25	121	74	40	22.0
	76.1	2.0	26.9	1.6	124.0	30	94.45	25	136	86	45	27.0
	33.7	2.0	33.7	2.0	124.5	25	78.55	25	98	53	33	13.0
	42.4	2.0	33.7	2.0	124.5	25	82.90	25	107	62	38	18.0
40	76.1	2.0	33.7	2.0	134.5	30	99.75	25	142	94	52	32.0
	42.4	2.0	42.4	2.0	152.0	25	97.00	25	122	62	37	8.4
	48.3	2.0	48.3	2.0	152.0	25	99.95	25	128	68	41	12.4
	60.3	2.0	48.3	2.0	162.0	30	105.95	25	140	82	48	19.4
50	76.1	2.0	48.3	2.0	162.0	30	113.85	25	155	97	55	26.4
	60.3	2.0	60.3	2.0	188.0	30	120.15	30	154	82	48	12.5
	76.1	2.0	60.3	2.0	188.0	30	128.05	30	172	100	56	20.5
	88.9	2.3	60.3	2.0	188.0	30	134.15	30	183	110	61	25.5

Dimensions [mm], continued

Welded body acc. to ASME BPE

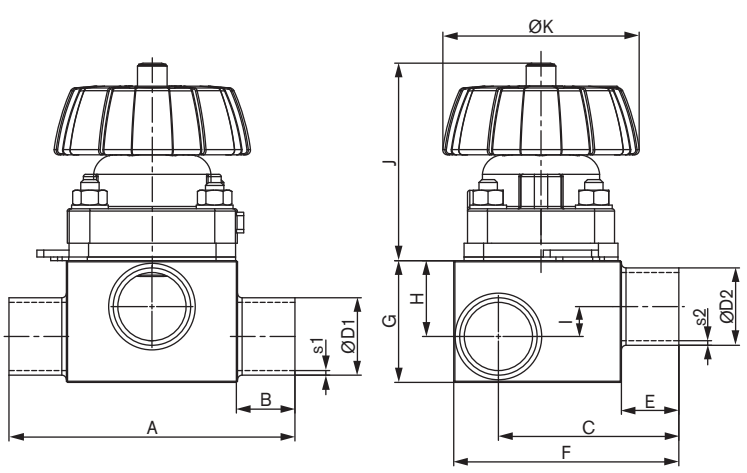

For all actuators

Orifice	J	ØK
8	48	34
15	77	85
20	84	85
25	86	85
40	105	114
50	120	114

Orifice	ØD1	s1	ØD2	s2	A	B	C	E	F	G	H	I
15	12.70	1.65	12.70	1.65	93.0	20	51.60	20	70	27	13.5	0.0
	19.05	1.65	12.70	1.65	103.0	20	54.78	20	70	31	18.5	5.0
	25.40	1.65	12.70	1.65	103.0	20	57.95	20	75	40	24	10.5
	38.10	1.65	12.70	1.65	103.0	25	64.30	20	88	54	31	17.5
	50.80	1.65	12.70	1.65	113.0	30	71.65	20	100	64	35	21.5
	63.50	1.65	12.70	1.65	113.0	30	78.80	20	113	73	38	24.5
20	19.05	1.65	19.05	1.65	114.0	25	66.28	25	85	36	18	0.0
	25.40	1.65	19.05	1.65	114.0	25	69.45	25	90	40	24	6.0
	38.10	1.65	19.05	1.65	114.0	25	75.80	25	98	53	31	13.0
	50.80	1.65	19.05	1.65	124.0	30	82.15	25	111	66	37	19.0
	63.50	1.65	19.05	1.65	124.0	30	88.50	25	123	75	40	22.0
	76.20	1.65	19.05	1.65	124.0	30	94.85	25	137	87	45	27.0
25	25.40	1.65	25.40	1.65	124.5	25	74.75	25	95	42	26	6.0
	38.10	1.65	25.40	1.65	124.5	25	81.10	25	103	58	36	16.0
	50.80	1.65	25.40	1.65	134.5	30	87.45	25	120	75	44	24.0
	63.50	1.65	25.40	1.65	134.5	30	93.80	25	130	83	48	28.0
	76.20	1.65	25.40	1.65	134.5	30	100.15	25	142	94	52	32.0
40	38.10	1.65	38.10	1.65	152.0	25	95.20	25	121	58	35	6.4
	50.80	1.65	38.10	1.65	162.0	30	101.55	25	131	72	43	14.4
50	50.80	1.65	50.80	1.65	188.0	30	115.75	30	145	71	42	6.5
	63.50	1.65	63.50	1.65	188.0	30	122.10	30	158	86	50	14.5

Dimensions [mm], continued

Welded body acc. to DIN 11850 Series 0 and 2

For all actuators

Orifice	J	ØK
8	48	34
15	77	85
20	84	85
25	86	85
40	105	114
50	120	114

Orifice	ØD1	s1	ØD2	s2	A	B	C	E	F	G	H	I
Series 0												
08	6.0	1.0	6.0	1.0	78.0	20	43.0	20	60	17	6.5	0.0
	40.0	1.5	6.0	1.0	88.0	25	60.5	20	83	51	29	19.0
	40.0	1.5	10.0	1.0	88.0	25	60.5	20	83	51	29	19.0
	52.0	1.5	6.0	1.0	98.0	30	66.5	20	95	60	32	22.0
25	28.0	1.5	28.0	1.5	124.5	25	76.2	25	95	46	29	9.0
	52.0	1.5	28.0	1.5	134.5	30	88.2	25	117	71	42	22.0
40	28.0	1.5	34.0	1.5	152.0	25	90.3	25	122	58	32	3.4
	52.0	1.5	34.0	1.5	162.0	30	102.3	25	132	75	45	16.4
50	52.0	1.5	52.0	1.5	188.0	30	116.5	30	147	73	43	7.5
Series 2												
15	19.0	1.5	19.0	1.5	93.0	20	54.9	20	70	33	20	6.5
	23.0	1.5	19.0	1.5	103.0	20	56.9	20	72	37	22.5	8.5
	35.0	1.5	19.0	1.5	103.0	25	62.9	20	84	50	29	14.5
	41.0	1.5	19.0	1.5	103.0	25	65.9	20	91	56	32	18.5
20	23.0	1.5	23.0	1.5	114.0	25	68.4	25	88	42	21	3.0
	35.0	1.5	23.0	1.5	114.0	25	74.4	25	95	50	29	11.0
	41.0	1.5	23.0	1.5	114.0	25	77.4	25	101	56	32	14.0
25	29.0	1.5	29.0	1.5	124.5	25	76.7	25	98	48	30	10.0
40	41.0	1.5	41.0	1.5	152.0	25	96.8	25	121	62	37	8.4
50	53.0	1.5	53.0	1.5	188.0	30	117.0	30	147	74	44	8.5

Dimensions [mm], continued

Welded body acc. to SMS 3008

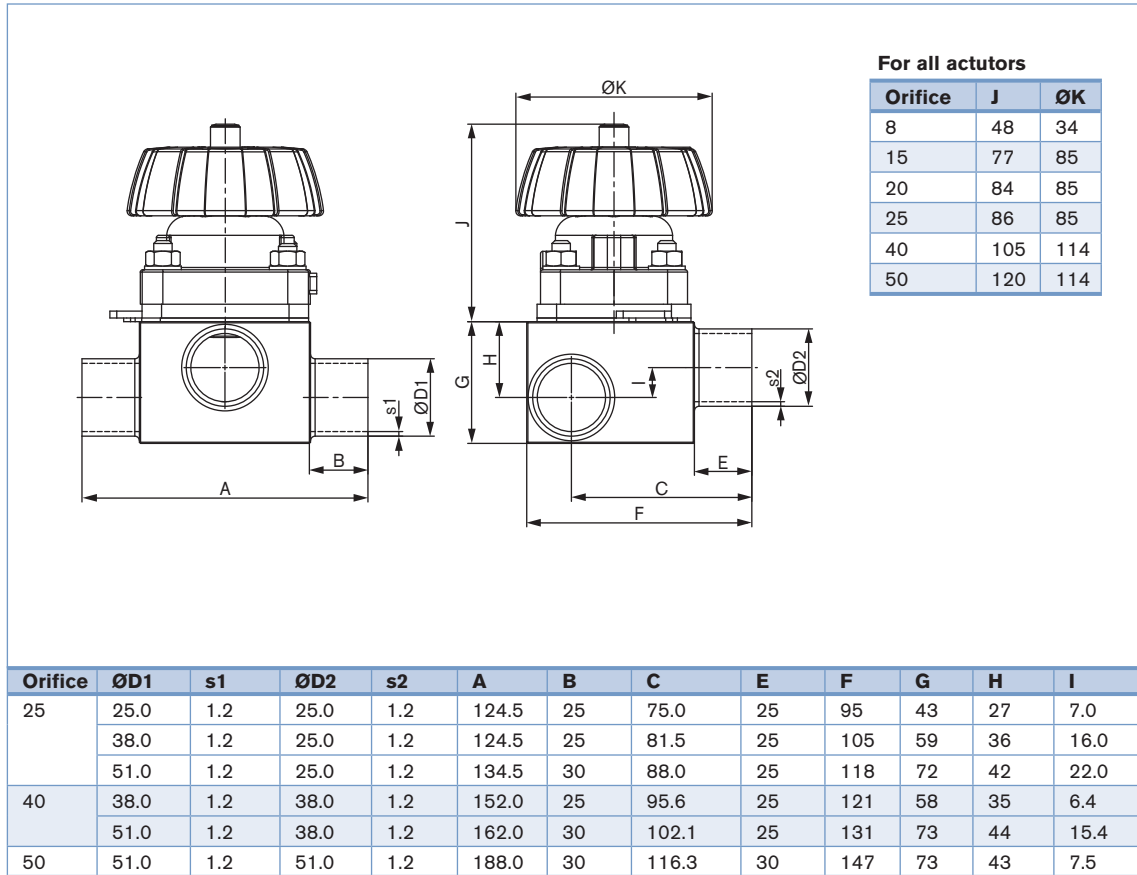

Dimensions [mm], continued

Clamp body

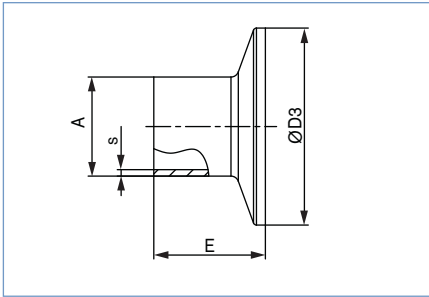

ASME BPE

Orifice		A	s	ØD3	E
[mm]	[inch]				
08	1/4"	6.35	0.89	25.0	28.6
10	3/8"	9.53	0.89	25.0	28.6
15	1/2"	12.7	1.65	25.0	28.6
20	3/4"	19.05	1.65	25.0	28.6
25	1"	25.4	1.65	50.5	28.6
40	1 1/2"	38.1	1.65	50.5	28.6
50	2"	50.8	1.65	64.0	28.6
65	2 1/2"	63.5	1.65	77.5	28.6
80	3"	76.2	1.65	91.0	28.6
100	4"	101.6	2.11	119.0	28.6

DIN 32676

Orifice [mm]	A	s	ØD3	E
10	1.5	34.0	18	18
15	19	1.5	34.0	18
20	23	1.5	34.0	18
25	29	1.5	50.5	21.5
32	35	1.5	50.5	21.5
40	41	1.5	50.5	21.5
50	53	1.5	64.0	21.5
65	70	2.0	91.0	28

ISO 2852 for pipe ISO 4200

Orifice [mm]	A	s	ØD3	E
8	13.5	1.6	25.0	28.6
8	13.5	1.6	34.0	28.6
10	17.2	1.6	34.0	28.6
15	21.3	1.6	34.0	28.6
15	21.3	1.6	50.5	28.6
20	26.9	1.6	50.5	28.6
25	33.7	2	50.5	28.6
32	42.4	2	50.5	28.6
40	48.3	2	64.0	28.6
50	60.3	2	77.5	28.6
65	76.1	2	91.0	28.6
100	114.3	2.3	130.0	28.6

SMS

Orifice [mm]	A	s	ØD3	E
25	25	1.2	50.5	21.5
40	38	1.2	50.5	28.6
50	51	1.2	64.0	28.6

Valve features

Example

15 AB B VH SA42 SA42 D050 NO15 + NO14 + HA24

Specification key

Please make a choice

ORIFICE [mm] (diaphragm)	
08	(only with DO58)
15	
20	
25	
40	
50	
80	
100	

SEAL MATERIAL	
AB	EPDM in food quality
EA	PTFE
FF	FPM (FKM)
EU	advanced PTFE

PRODUCTION OF BODY	
B	Monoblock

BODY MATERIAL	
VH	AISI 316L
VI	1.4435 BN2/ASME

VARIABLE CODES		
Surface finish External		
NO03	Ext. Mirror finished Ra=0.25µm	
NO09	Ext. Electro polished RA=3.2µm	
NO15	Ext. Electro polished Ra=0.8µm	
NO19	Ext. Mech. polished Ra=1.6µm	
NO22	Ext. Glass beaded Ra=3.2µm	standard
Surface finish Internal		
NO07	Int. Mirror finished Ra=0.25µm	
NO10	Int. Electro polished Ra=0.8µm	
NO14	Int. Mech. polished Ra=0.5µm	standard
NO17	Int. Electro finished Ra=0.4µm	
NO20	Int. Electro polished Ra=0.25µm	
Handwheel		
HA24	with locking function	

ACTUATOR VERSION		
D050	Top PPS Handwheel PPS	not possible with orifice 08
D058	Top stainless steel, Handwheel PPS for T-valve	



Flange 1 (main tube) connection
Flange 2

Port connection weld end

Orifice [mm]	EN ISO 1127/ ISO 4200	SMS 3008	DIN 11850 Series 0	Series 1	Series 2	Series 3	BS 4825	ASME BPE	JIS Sanitary	JIS Utility
4			SC40=6x1.0							
6			SC41=8x1.0							
8	SA40=13.5x1.6		SC42=10x1.0				SODB=6.35x1.2	SA90=6.35x0.89	SA70=13.8x1.65	
10	SA41=17.2x1.6			SF40=12x1.0	SD40=13x1.5	SE40=14x2.0	SODC=9.53x1.2	SA91=9.53x0.89	SA71=17.3x1.65	
15	SA42=21.3x1.6		SC43=18x1.5	SF41=18x1.0	SD42=19x1.5	SE42=20x2.0	SODD=12.7x1.2	SA92=12.7x1.65	SA72=21.7x2.1	
20	SA43=26.9x1.6		SC44=22x1.5	SF42=22x1.0	SD43=23x1.5	SE43=24x2.0	SODE=19.05x1.2	SA93=19.05x1.65	SA76=27.2x2.1	SA80=27.2x2.1
25	SA44=33.7x2.0	SA60=25.0x1.2	SC45=28x1.5	SF43=28x1.0	SD44=29x1.5	SE44=30x2.0	SODF=25.4x1.65	SODF=25.4x1.65	SA73=25.4x1.2	SA81=34x2.0
32	SA45=42.4x2.0		SC46=34x1.5	SF44=34x1.0	SD45=35x1.5	SE45=36x2.0				SA83=42.7x2.0
40	SA46=48.3x2.0	SA62=38.0x1.2	SC47=40x1.5	SF45=40x1.0	SD46=41x1.5	SE46=42x2.0	SODH=38.1x1.65	SODH=38.1x1.65	SA74=38.1x1.2	SA83=48.6x2.0
50	SA47=60.3x2.0	SA63=51.0x1.2	SC48=52x1.5	SF46=52x1.0	SD47=53x1.5	SE47=54x2.0	SODI=50.8x1.65	SODI=50.8x1.65	SA75=50.8x1.5	SA84=60.5x2.0
65	SA48=76.1x2.0	SA64=63.5x1.6			SD48=70x2.0		SA64=63.5x1.65	SA64=63.5x1.65		
80	SA49=88.9x2.3	SA65=76.1x1.6			SD49=85x2.0		SA65=76.2x1.65	SA65=76.2x1.65		
100	SA39=114.3x2.3	SA66=101.6x2.0			SD50=104x2.0		SA66=101.6x2.11	SA66=101.6x2.11		

Port connection clamp

Orifice DN [mm]	ISO 2852 SMS 3017	ASME BPE	DIN 32676
8	TC51=Clamp 34 - for tube ISO 4200	TG50=Clamp 25 - Tube 6.35x0.89	
10	TC41=Clamp 34 - for tube ISO 4200	TG01=Clamp 25 - Tube 9.53x0.89	TD41=Clamp 34 - Tube 13x1.5
15	TC42=Clamp 34 - for tube ISO 4200	TG02=Clamp 25 - Tube 12.7x1.65	TD42=Clamp 34 - Tube 19x1.5
20	TC43=Clamp 50.5 - for tube ISO 4200	TG03=Clamp 25 - Tube 19.05x1.65	TD43=Clamp 34 - Tube 23x1.5
25	TC44=Clamp 50.5 - for tube ISO 4200	TG04=Clamp 50.5 - Tube 25.4x1.65	TD44=Clamp 50.5 - Tube 29x1.5
40	TC46=Clamp 64 - for tube ISO 4200	TG05=Clamp 50.5 - Tube 38.1x1.65	TD46=Clamp 50.5 - Tube 41x1.5
50	TC47=Clamp 77.5 - for tube ISO 4200	TG06=Clamp 64 - Tube 50.8x1.65	TD47=Clamp 64 - Tube 53x1.5
65	TC48=Clamp 91 - for tube ISO 4200	TG07=Clamp 77.5 - Tube 63.5x1.65	TD48=Clamp 91 - Tube 70x2
80	-	TG08=Clamp 91 - Tube 76.2x1.65	-
100	TC50=Clamp 130 - for tube ISO 4200	TG09=Clamp 119 - Tube 101.6x2.11	-