

3/2-Way, direct acting, G 1/8

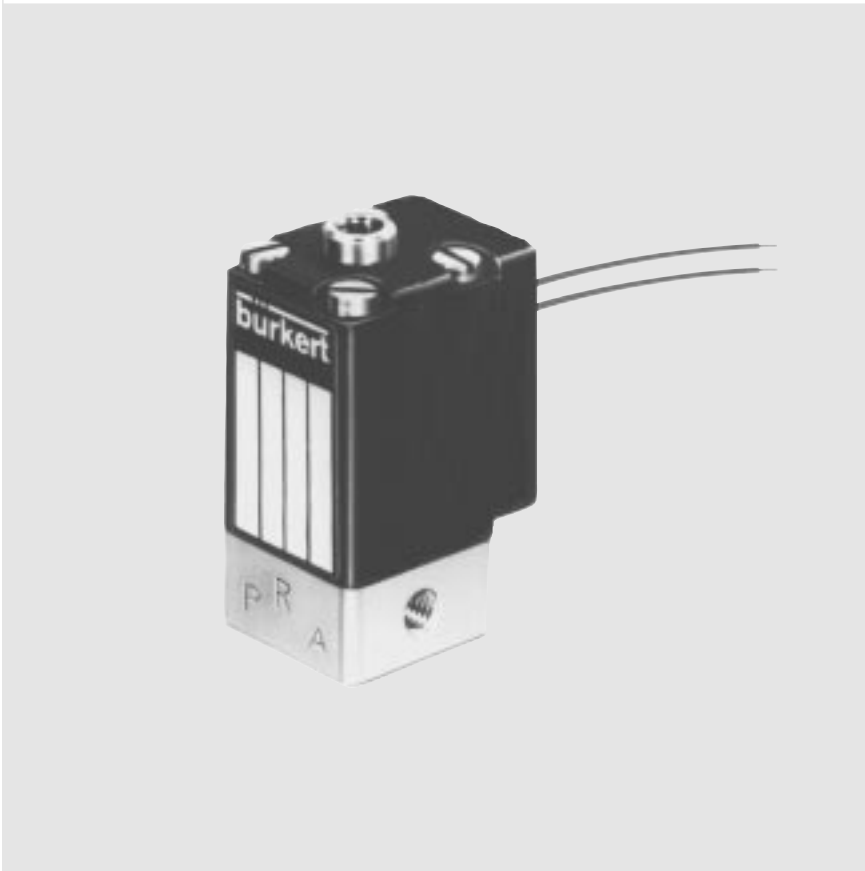

### Advantages/Benefits

- ▶ Compact design
- ▶ Specific testing and cleaning available
- ▶ Short response times
- ▶ Electrical connection: DIN-plug or leads
- ▶ Manual override
- ▶ When de-energized, outlet port exhausted or pressurized, mixer valve
- ▶ Body materials: brass (stainless steel on request)

### Design/Function

Type 300 is a direct-acting plunger-type solenoid valve available in a variety of different circuit functions, to suit the respective application.

When energized, the solenoid armature is drawn against a spring. The solenoid epoxy encapsulation efficiently dissipates the heat generated by the coil.

The valve is available in brass (stainless steel on request). Electrical connections are DIN-plug or leads. Specific testing and cleaning and low power versions are available on request.

### Applications

- Neutral gases and liquids
- Pneumatic control equipment
- Vacuum
- Shut-off, dosing, filling and ventilating
- Gas control, welding technology
- Small-scale instruments, laboratory and measuring technology

## Technical Data

### Circuit Function

**C** 3/2-way valve, when de-energized, outlet A exhausted (normally closed)

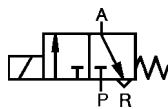

**D** 3/2-way valve, when de-energized, outlet B pressurized (normally open)

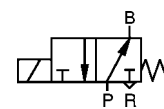

### Operating Data (Valve)

Pressure range max.	0-10 bar (see specifications)
Port connection	Threaded port G 1/8", Subbase on request.
Orifice	DN 1.2 - 1.6 mm >DN 1.6 mm on request.
Fluid	Neutral gases and liquids, e.g. compressed air, town gas, natural gas, water, hydraulic oil, petrol. Stainless steel version: Slightly aggressive media. Suitable for techn. vacuum.
Medium temperature	-10 to +100 °C
Max. ambient temperature	+55 °C
Max. viscosity	21 mm <sup>2</sup> /s
Response times	
opening	12 ms
closing	8 ms
Installation	as required, but preferably with solenoid system upright

### Operating Data (Actuator)

Operating voltages	AC 24, 110, 230 V/50 Hz, DC 24 V/=						
Voltage tolerance	±10 %						
Power consumption	<table border="1"> <thead> <tr> <th>AC inrush</th> <th>AC hold</th> <th>DC</th> </tr> </thead> <tbody> <tr> <td>9 VA</td> <td>6 VA/4 W</td> <td>4 W<sup>1)</sup></td> </tr> </tbody> </table>	AC inrush	AC hold	DC	9 VA	6 VA/4 W	4 W <sup>1)</sup>
AC inrush	AC hold	DC					
9 VA	6 VA/4 W	4 W <sup>1)</sup>					
	<sup>1)</sup> Power consumption DC 2 W on request						
Duty cycle	100% continuously rated 60% for manifold mounting (30 min) or use 2W-version (on request)						
Duty cycle for multiple manifolds							
Cycling rate	up to 1 000 c.p.m.						
Protection class with cable plug	IP 65						
Electr. connection	Delivery standard: Cable plug DIN 43 650 B, 0-250 V. Flying leads						

## Materials

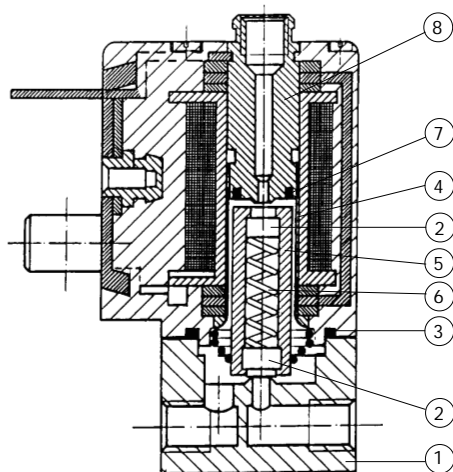

1 Valve body:	Brass (Stainless steel on request)
2 Plunger-seal:	FKM
3 O-rings:	FKM
4 Armature guide tube:	S.Steel 1.4303
5 Plunger:	S.Steel 1.4105
6 Spring:	S.Steel 1.4310
7 Shading ring:	Cu (brass version)
8 Stopper:	1.4105

## Specifications - Ordering Chart (Other Versions on Request)



### Valve body brass, manual override standard, cable plug DIN 43 650 form B

Port connection	Orifice [mm]	Kv-Value (water) [m³/h]	QNn (air) [l/min]	Pressure Range		Seal material	Weight [kg]	I T E M - No.		
				(AC) [bar]	(DC) [bar]			Voltage / Frequency [V/Hz]		
				24/DC	110/50			230/50		
G 1/8	1.2	0.045	48	0-10	0-10	FKM	0.12	136 496 C	136 497 D	136 498 N
G 1/8	1.6	0.060	65	0- 6	0- 6	FKM	0.12	136 499 P	136 500 U	136 501 R

### Valve body brass, without manual override, cable plug DIN 43 650 form B

G 1/8	1.2	0.045	48	0-10	0-10	FKM	0.12	136 508 Y	136 509 Z	136 510 M
G 1/8	1.6	0.060	65	0- 6	0- 6	FKM	0.12	136 511 A	136 512 B	136 513 C

### Valve body brass, manual override standard, coil with two flying leads

G 1/8	1.2	0.045	48	0-10	0-10	FKM	0.12	136 502 J	----	----
G 1/8	1.6	0.060	65	0- 6	0- 6	FKM	0.12	136 505 M	----	----

### Valve body brass, without manual override, coil with two flying leads

G 1/8	1.2	0.045	48	0-10	0-10	FKM	0.12	136 514 D	----	----
G 1/8	1.6	0.060	65	0- 6	0- 6	FKM	0.12	136 517 G	----	----

### Valve body brass, manual override standard, coil with three flying leads

G 1/8	1.2	0.045	48	0-10	0-10	FKM	0.12	---	136 503 K	136 504 L
G 1/8	1.6	0.060	65	0- 6	0- 6	FKM	0.12	----	136 506 N	146 507 P

### Valve body brass, without manual override, coil with three flying leads

G 1/8	1.2	0.045	48	0-10	0-10	FKM	0.12	----	136 515 E	136 516 F
G 1/8	1.6	0.060	65	0- 6	0- 6	FKM	0.12	----	136 518 R	136 519 J

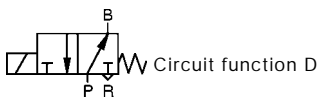

### Valve body brass, without manual override, cable plug DIN 43 650 form B

Port connection	Orifice [mm]	Kv-Value (water) [m³/h]	QNn (air) [l/min]	Pressure Range		Seal material	Weight [kg]	I T E M - No.		
				(AC) [bar]	(DC) [bar]			Voltage / Frequency [V/Hz]		
				24/DC	110/50			230/50		
G 1/8	1.2	0.045	48	0-10	0-10	FKM	0.12	136 484 G	136 485 H	136 486 A
G 1/8	1.6	0.060	65	0- 6	0- 6	FKM	0.12	136 487 B	136 488 L	136 489 M

### Valve body brass, without manual override, coil with two flying leads

G 1/8	1.2	0.045	48	0-10	0-10	FKM	0.12	136 490 J	----	----
G 1/8	1.6	0.060	65	0- 6	0- 6	FKM	0.12	136 493 H	----	----

### Valve body brass, without manual override, coil with three flying leads

G 1/8	1.2	0.045	48	0-10	0-10	FKM	0.12	---	136 491 F	136 492 G
G 1/8	1.6	0.060	65	0- 6	0- 6	FKM	0.12	----	136 494 A	136 495 B

## Options

- 2W-version
- Stainless steel body
- Specific testing and cleaning
- Manual override



## Dimensions Solenoid Valve [mm]

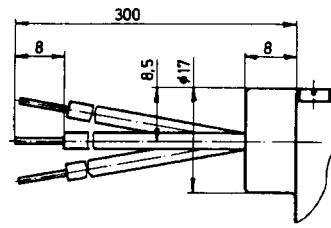
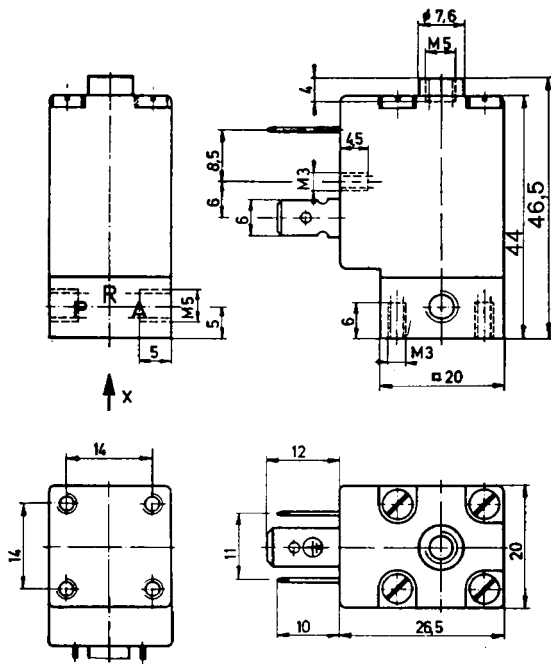

Please note for G 1/8 port connection:

Body length 25 mm, overall height 48 mm, M5 connection is retained at R port

## Technical Data Cable Plug

Body material	PA (polyamide)
Contact material	brass, tinned
Cable outlet	vertically to the plug bottom
Isolation between cable plug and coil	gasket (NBR)
Temperature range	-30°C ... +90°C
Cable diameter	4.5 ... 7 mm
Electr. connection	terminal screws max. 1,5 mm <sup>2</sup>
Poles	2pole + protective earth
Nominal voltage	0-250 V (Standard)
Isolation group	3
Rating	IP 65
Max. continuous current	16 A without wiring
Contact resistance	≤ 4 mΩ
Options	LED display Rectifier Varistor

## Dimensions Cable Plug [mm]

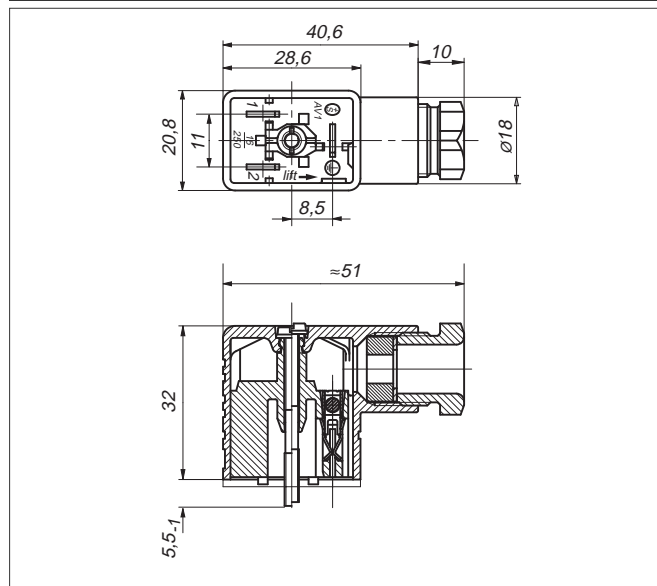

Cable plug type 2507

## Wiring Diagrams/Connection Specifications

