



2/2- and 3/2-way ball valve, 2 piece

- Stainless steel ball valve
- High flow rate
- Favourable flow rate
- ISO 5211 Top flange

Type 2651 can be combined with...



Type 2051
Pneumatic
actuator



Type 2052
Pneumatic
actuator



Type 3003
Electric
actuator



Type 3004
Electric
actuator



Type 3005
Electric
actuator

2/2- and 3/2-way stainless steel ball valve used to shut off medium flows. The ball valves can be connected via the mechanical interface to ISO 5211 with a pneumatic (for example, Type 2051 or 2052) or electrical rotary actuator (eg, Types 3003, 3004 or 3005).

- Long life
- High medium pressure
- 3/2-way Version with L- or T-boring

Technical data	
Orifice	DN10 to 50 (2/2- way) DN10 to 40 (3/2- way)
Ball bore (3/2- Wege)	L - Boring T - Boring
Body material	Stainless steel 1.4408
Ball material	Stainless steel 1.4401
Selector shaft material	Stainless steel 1.4401
Seal material	PTFE (Ball seal) FKM (Stem Seal)
Medium temperature	-10 to 200 °C (see pressure temperature diagram)
Medium pressure	max. 100 bar (2/2-way) (see pressure temperature diagram) max. 63 bar (3/2-way) (see pressure temperature diagram)
Medium	Stainless steel body: aggressive mediums, which do not affect the body or seal materials
Port Connection	G 1/4 - G 2 Thread acc. DIN EN 10226-1 (old DIN 2999) weld end
ISO Top flange	EN ISO 5211

Further technical data

Pressure / Temperature diagram

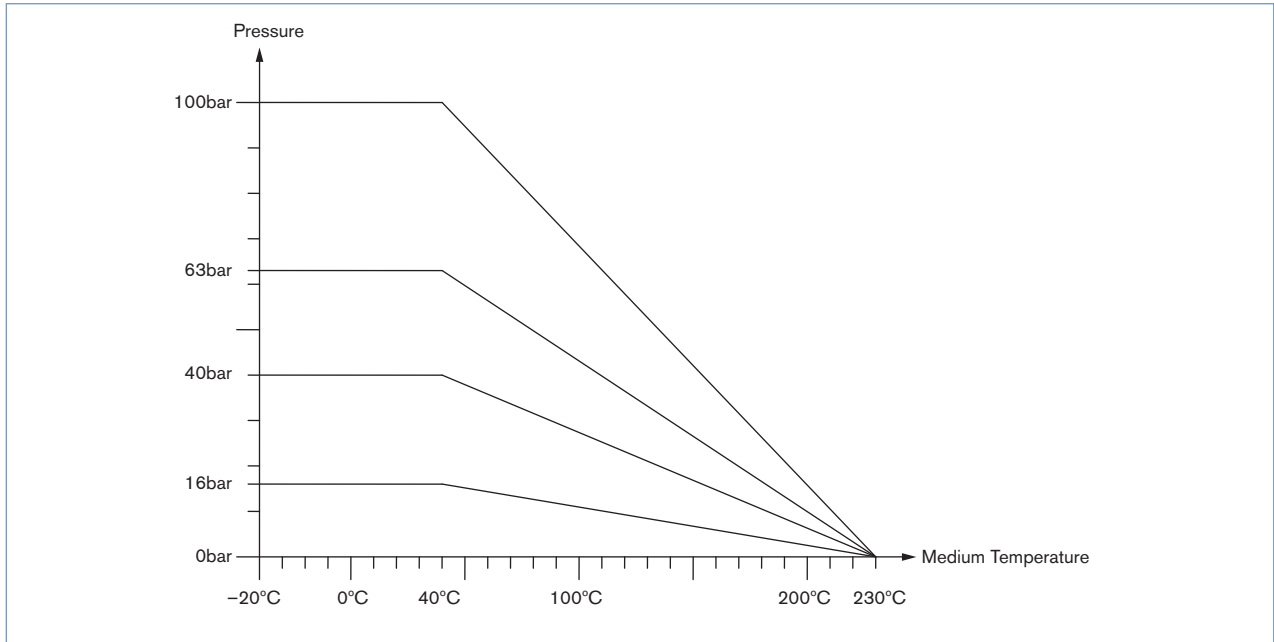

Torques

2/2-way,

DN	10	12	15	20	25	32	40	50
Breakaway torque [Nm]	13	13	16	25	31	53	76	99
Running torque [Nm]	10	10	13	20	24	43	60	80

3/2-way

DN	10	12	15	20	25	32	40
Breakaway torque [Nm]	13	13	18	22	35	42	68
Running torque [Nm]	9	9	12	14	23	28	45

The given values were measured at max. delta P with water at ambient temperature.

Switching positions 3-way

Ball bore		T			L
Position	0°				
	90°				
Switching position		T1	T2	T3	L4

Dimensions / Ordering chart [mm]

2-way, threaded

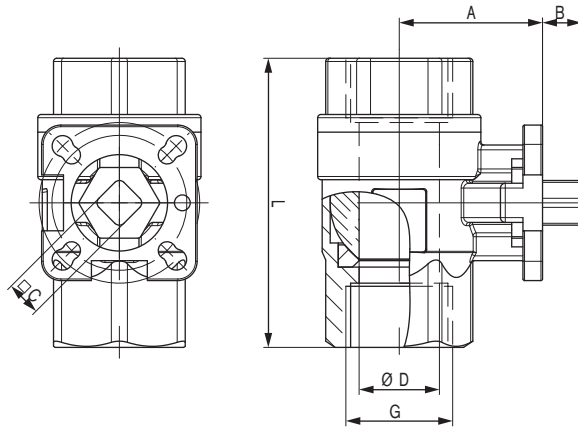

DN [mm]	LTA	D	L	A	B	C	ISO 5211	Item no.
10	1/4"	11.6	50	33.2	7	9	F03	185 972
12	3/8"	12.7	60	33.2	7	9	F03/F04	185 973
15	1/2"	15	75	35	7.5	9	F03/F04	185 974
20	3/4"	20	80	41	12.1	11	F03/F04	185 975
25	1"	25	90	44.5	12.1	11	F04/F05	185 976
32	1 1/4"	31.8	110	49.5	11.5	11	F04/F05	185 977
40	1 1/2"	38	120	55	12.1	11	F04/F05	185 978
50	2"	50.8	140	66.5	15.5	14	F05/F07	185 979

3-way, threaded

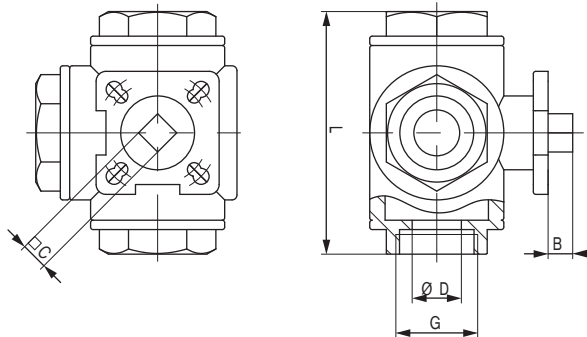

DN [mm]	LTA	D	L	B	C	ISO 5211	Item no.	
							L - Boring	T - Boring
10	1/4"	10	80	7.4	9	F03/F04	172 844	185 984
12	1/2"	12	80	7.4	9	F03/F04	185 853	185 987
15	3/4"	15	87.5	7.4	9	F03/F04	172 845	185 988
20	1"	20	100	12.8	11	F04/F05	172 847	185 989
25	1 1/4"	25	123	11.4	11	F04/F05	172 848	185 990
32	1 1/2"	32	142.2	12.4	11	F04/F05	172 849	185 992
40	2"	40	170.6	9.8	11	F04/F05	172 851	185 993