

## Pneumatic rotary drive



- Modular program for mounting of quarter turn valves such as ball valves and butterfly valves
- NAMUR and ISO 5211 interfaces
- Position feedback (including Ex-Versions)
- SideControl Positioner ready

Type 2052 can be combined with...



**Type 2654**

Stainless steel ball valve



**Type 2671**

Metal butterfly valve



**Type 2657**

Plastic ball valve



**Type 2674**

Plastic butterfly valve



**Typ 6519**

Solenoid valve

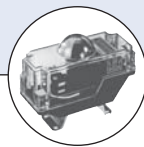

**Type TEUXXX**

Position feedback

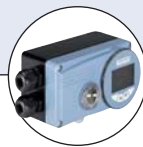

**Type 8792**

Positioner SideControl

The 2052 pneumatic rotary drives are single or double-acting pneumatic linear piston actuators where linear movement of the piston due to the pilot air causes a 90° rotation of the connected valve. Actuator-valve coupling is made via a universal ISO 5211 mechanical interface and the status of ball or butterfly valve can be monitored at a control system through a range of rugged feedback switches. The drives can also be used as modulating control actuators by the addition of Bürkert's range of SideControl positioners. The actuators are available in an aluminium and in a polyamide version. Both kinds of actuators have the advantage, that they are maintenance free and highly resistant to corrosion.

**Control function A**

Single-acting actuator return by spring, operating e.g. with pilot valve

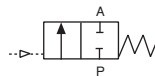

**Control function I**

Double-acting actuator, operating e.g. with pilot valve

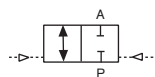

**Control function B (optional)**

Single-acting actuator return by spring, operating e.g. with pilot valve

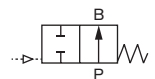

Function principles see p. 3

Technical Data	Aluminium Actuator	Polyamide Actuator
<b>Materials</b>		
Actuator	aluminium (cataphoresis/polyamide coating)	polyamide + glass fiber
Piston	aluminium (cataphoresis coating); polyarylamid <sup>1)</sup>	polyarylamide
Seal	NBR	NBR
<b>Control medium</b>	filtered compressed air with or without oil; water	filtered compressed air with or without oil; water
<b>Control pressure</b>	3-8 bar	3-8 bar
<b>Tumg</b>	-32 °C up to +90 °C	-32 °C up to +90 °C
<b>Rotation</b>	90° (optional 180°)	90°
<b>Adjustable angle</b>	-2° up to 5° / 85° up to 92°	-
<b>Interface</b>		
Pilot air ports	NAMUR flange interface VDI/VDE 3845 G 1/4	NAMUR flange interface VDI/VDE 3845 G 1/4
Feedback signal	NAMUR VDI/VDE 3845	NAMUR VDI/VDE 3845
Fittings	ISO 5211	ISO 5211
<b>Certifications</b>	<ul style="list-style-type: none"> <li>▪ ATEX 94/9/EC</li> <li>▪ Pressure Equipment Directive 97/23/EC (PED)</li> <li>▪ IEC 61508 SIL3 <sup>2)</sup></li> <li>▪ Det Norske Veritas (DNV)</li> </ul>	<ul style="list-style-type: none"> <li>▪ ATEX 94/9/EC</li> <li>▪ Pressure Equipment Directive 97/23/EC (PED)</li> <li>▪ IEC 61508 SIL3</li> <li>▪ Det Norske Veritas (DNV)</li> </ul>

<sup>1)</sup> Only for actuator in size W

<sup>2)</sup> Exceptions are marked on page 2

## Ordering chart - Aluminium actuator (other versions on request)

### Double-acting actuator (Control function I)

Actuator size	Torque [Nm] dependent on control pressure							Air volume [l]		Weight [kg]	Item no.
	Control pressure [bar]							opening	closing		
	3	4	5	5,5	6	7	8				
W	7.90	11.30	14.10	15.50	17.00	19.80	22.90	0.075	0.11	0.92	254 851
J / 00	11.60	16.10	20.50	22.70	25.00	29.50	33.90	0.15	0.18	1.40	254 852
5 / 05	23.50	32.30	41.00	45.30	49.70	58.40	67.10	0.28	0.37	2.57	254 853
K / 10	32.90	45.60	58.30	65.00	71.00	83.70	96.40	0.35	0.45	3.08	254 854
L / 15	55.20	75.60	96.00	106.20	116.50	136.90	157.40	0.65	0.82	4.20	254 855
Q / 20	77.70	107.00	136.30	151.00	165.50	194.80	224.00	0.80	1.15	5.61	254 856
Y / 25	140.10	190.10	240.00	264.90	290.00	339.90	393.90	1.50	2.02	9.30	254 857
M / 30	226.50	307.40	388.00	428.70	469.00	550.10	631.00	2.05	3.00	11.60	254 858 (SIL2)

### Single-acting actuator (Control function A, 6 spring packages per side)

Actuator size	Torque [Nm] dependent on control pressure								Air volume [l]		Weight [kg]	Item no.
	Control pressure [bar]						Spring force		opening	closing		
	5		6		8		90°	0°				
0°	90°	0°	90°	0°	90°	90°	0°					
W	7.40	4.10	10.30	7.00	16.20	12.90	10.00	6.70	0.075	0.11	1.00	254 859
J / 00	9.40	4.00	13.90	8.50	22.80	17.40	16.50	11.10	0.15	0.18	1.63	254 860
5 / 05	20.10	9.60	28.80	18.30	46.20	35.70	31.40	20.90	0.28	0.37	2.94	254 861
K / 10	27.50	12.70	40.20	25.40	65.60	50.80	45.60	30.80	0.35	0.45	3.48	254 862
L / 15	47.00	24.50	67.50	45.00	108.40	85.90	71.50	49.00	0.65	0.82	5.04	254 863
Q / 20	70.50	31.60	99.70	60.80	158.20	119.30	104.70	65.80	0.80	1.15	6.63	254 864
Y / 25	120.60	58.20	170.60	108.20	274.50	212.10	181.80	119.40	1.50	2.02	11.30	254 865
M / 30	192.60	98.00	273.50	178.90	435.30	340.70	290.30	195.70	2.05	3.00	15.30	254 866

## Ordering chart - Polyamide actuator (other versions on request)

### Double-acting actuator (Control function I)

Actuator size	Torque [Nm] dependent on control pressure							Air volume [l]		Weight [kg]	Item no.
	Control pressure [bar]							opening	closing		
	3	4	5	5,5	6	7	8				
W	7.90	11.30	14.10	15.50	17.00	19.80	22.90	0.075	0.05	0.47	276 763
J / 00	13.30	18.30	23.40	26.00	28.50	33.60	38.70	0.15	0.18	0.83	276 764
K / 10	32.90	45.60	58.30	65.00	71.00	83.70	96.40	0.35	0.45	1.65	276 765
Q / 20	77.70	107.00	136.30	150.90	165.40	194.80	224.00	0.8	1.15	3.22	276 766

### Single-acting actuator (Control function A, 6 spring packages per side)

Actuator size	Torque [Nm] dependent on control pressure								Air volume [l]		Weight [kg]	Item no.
	Control pressure [bar]						Spring force		opening	closing		
	5		6		8		90°	0°				
0°	90°	0°	90°	0°	90°	90°	0°					
W	7.40	4.10	10.30	7.00	16.20	12.90	10.00	6.70	0.075	0.05	0.55	276 767
J / 00	10.70	4.60	15.80	9.70	26.00	19.90	18.80	12.70	0.15	0.18	1.00	276 768
K / 10	27.50	12.70	40.20	25.40	65.60	50.80	45.60	30.80	0.35	0.45	2.03	260 114
Q / 20	70.50	31.60	99.70	60.80	158.20	119.30	104.70	65.80	0.80	1.15	4.22	276 769

## Ordering chart – accessories to mount a positioner

Specifications	Item no.
universal adapter for shaft	787 338
universal assembly bridge	770 294

## Functional principle

### Control function A

Air supplied to port "2" forces the pistons towards the actuator end caps, compressing the springs. A counter-clockwise rotation is achieved. Exhaust air exits from port 4.

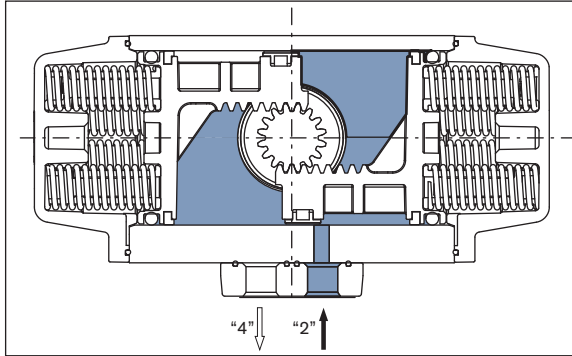

The loss of air pressure (air or electric failure) at port "2" allows the springs to force the pistons inwards. A clockwise rotation is achieved. Exhaust air exits from port 2.

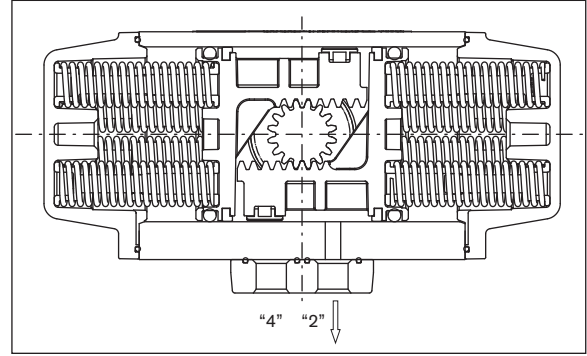

### Control function B (optional)

Is the opposite rotating direction of control function A.

### Control function I

Air supplied to port 2 forces the pistons towards the actuator end caps. A counterclockwise rotation is achieved. Exhaust air exits from port 4.

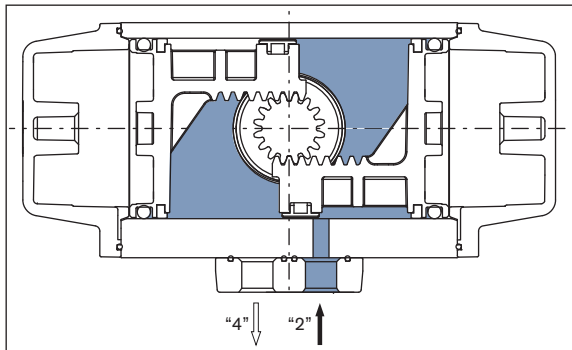

Air supplied to port 4 forces the pistons inwards. A clockwise rotation is achieved. Exhaust air exits from port 2.

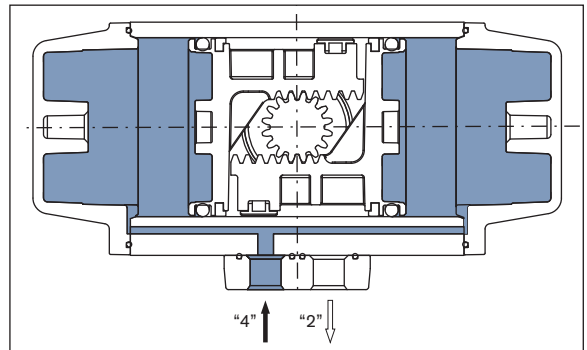

Note: Top view

Dimensions [mm] - Aluminium actuator

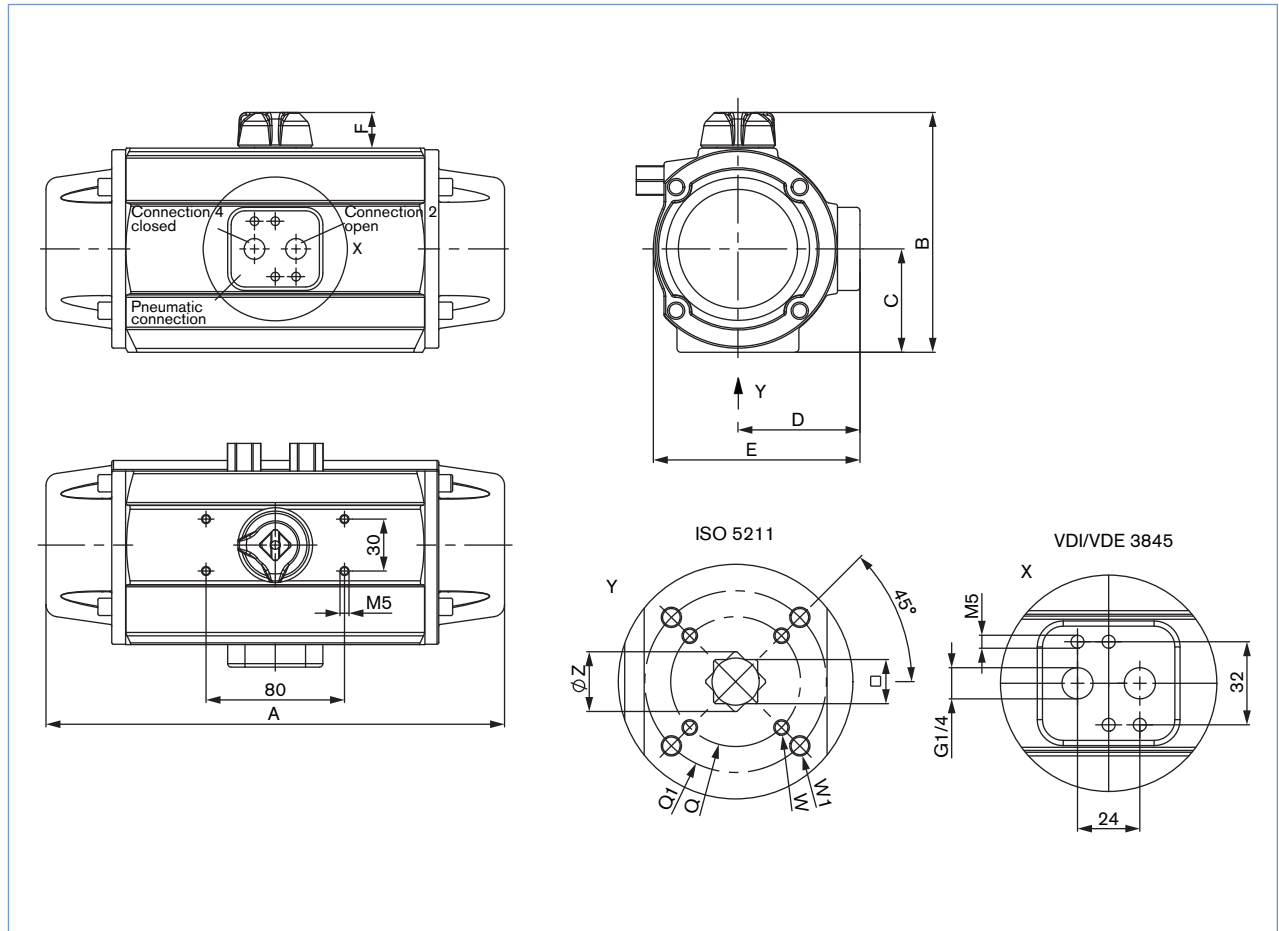

Size	A	B	C	D	E	F	Q	Q1	W	W1	Ø Z1	SW	ISO5211
W	140.2	89.3	37.2	48.2	76.1	20	36	42	M5	M5	14.3	11	F03-04
J / 00	152.3	102.1	43.2	52.2	84.1	20	42	50	M5	M6	19	14	F04-05
5 / 05	201.2	119	49.2	61.7	101.6	20	50	70	M6	M8	23	17	F05-07
K / 10	225.1	123.1	52.2	62.7	103.6	20	50	70	M6	M8	23	17	F05-07
L / 15	264.2	138.6	59.7	70.5	119.4	20	50	70	M6	M8	23	17	F05-07
Q / 20	311	147.3	63.7	75.1	127.5	20	50	70	M6	M8	29	22	F05-07
Y / 25	356.2	174.6	77.2	89.2	153.5	20	70	102	M8	M10	36.5	27	F07-10
M / 30	427.5	191	86.3	97.2	169	20	70	102	M8	M10	36.5	27	F07-10

Dimensions [mm] - Polyamide actuator

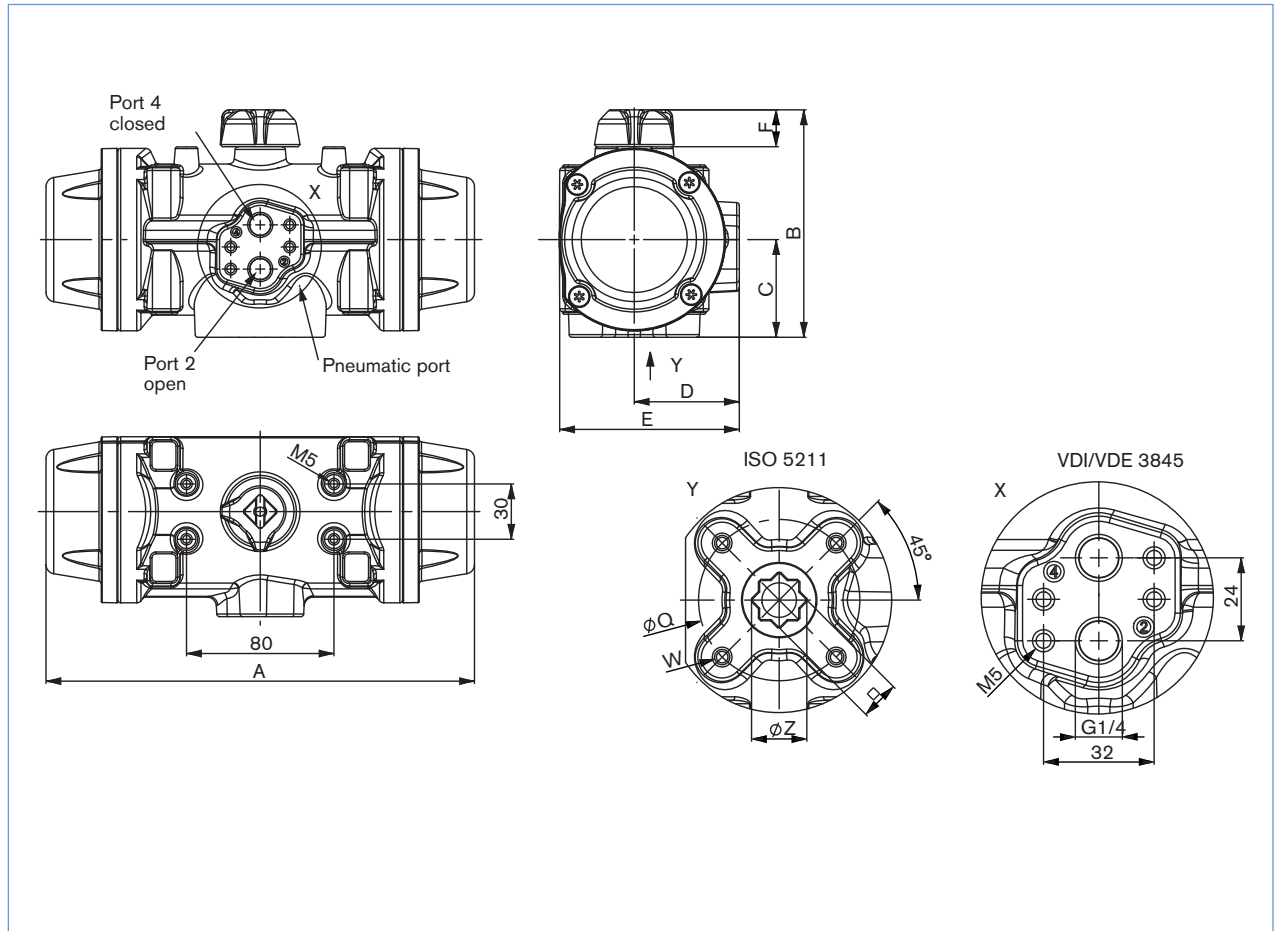

Size	A	B	C	D	E	F	Q	W	Ø Z1	SW	ISO5211
W	144	89	35.5	42.5	70.4	20	42 (36 optional)	M5	14.1	11	F04 (F03 optional)
J / 00	158	101.4	43	47.5	77.6	20	50	M6	19	14	F05
K / 10	230	123	52.7	56.5	97.1	20	70	M8	23	17	F07
Q / 20	313	146.4	63.8	67.5	120.6	20	70	M8	29	22	F07