

## 2/2-way Solenoid Valve for high pressures and temperatures



Type 0255 can be combined with...



**Type 2508**

Cable plug



**Type 1078**

Timer unit



**Type 2511**

ASI cable plug

- Seat valve, direct-acting
- Pressure range up to 100 bar
- Media temperature up to 250 °C
- Push-over solenoid system
- For gases and fluids

The direct-acting plunger solenoid valve Type 0255 is also suitable for high pressures and high temperatures.

Circuit function A

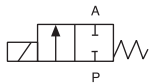

2/2-way valve, normally closed by spring force

Technical data	
<b>Orifice</b>	DN 1.0 - 6.0 mm
<b>Body material</b>	Brass with stainless steel seat 1.4305 or stainless steel body 1.4581
<b>Coil material</b>	Epoxy
<b>Coil insulation class</b>	H
<b>Seal material</b>	FKM, PTFE (others on request)
<b>Media</b>	FKM PTFE
	Hot air, hot oils, oils with additives, per-solutions Water, steam, fuels, hydraulic materials, alcohol, organic solvents, waste gas
<b>Media temperature</b>	FKM PTFE Steel
	-10 to +130 °C -40 to +180 °C Up to + 250 °C (on request)
<b>Viscosity</b>	Max. 21 mm <sup>2</sup> /s
<b>Ambient temperature</b>	Max. + 55°C (250 °C on request), please see ordering chart
<b>Voltage tolerance</b>	± 10%
<b>Duty cycle</b>	100% continuous rating
<b>Electrical connection</b>	Cable plug for Ø 7 mm cable, acc. to DIN EN 175301-803 Form A (supplied as standard)
<b>Protection class</b>	IP 65 with cable plug
<b>Weight [kg]</b>	0.6 (brass version)
<b>Installation</b>	As required, preferably with actuator upright

Power consumption		
Inrush	Hold (hot coil) <sup>1)</sup>	
AC [VA]	AC [VA/W]	DC [W]
35-40	16/10	approx.12 (13)

<sup>1)</sup> value in brackets at coil temperature 20 °C

Response times				
Orifice [mm]	Opening [ms]		Closing [ms]	
	AC	DC	AC	DC
1.0-6.0	10-20	20-80	20-30	20-30

## Materials

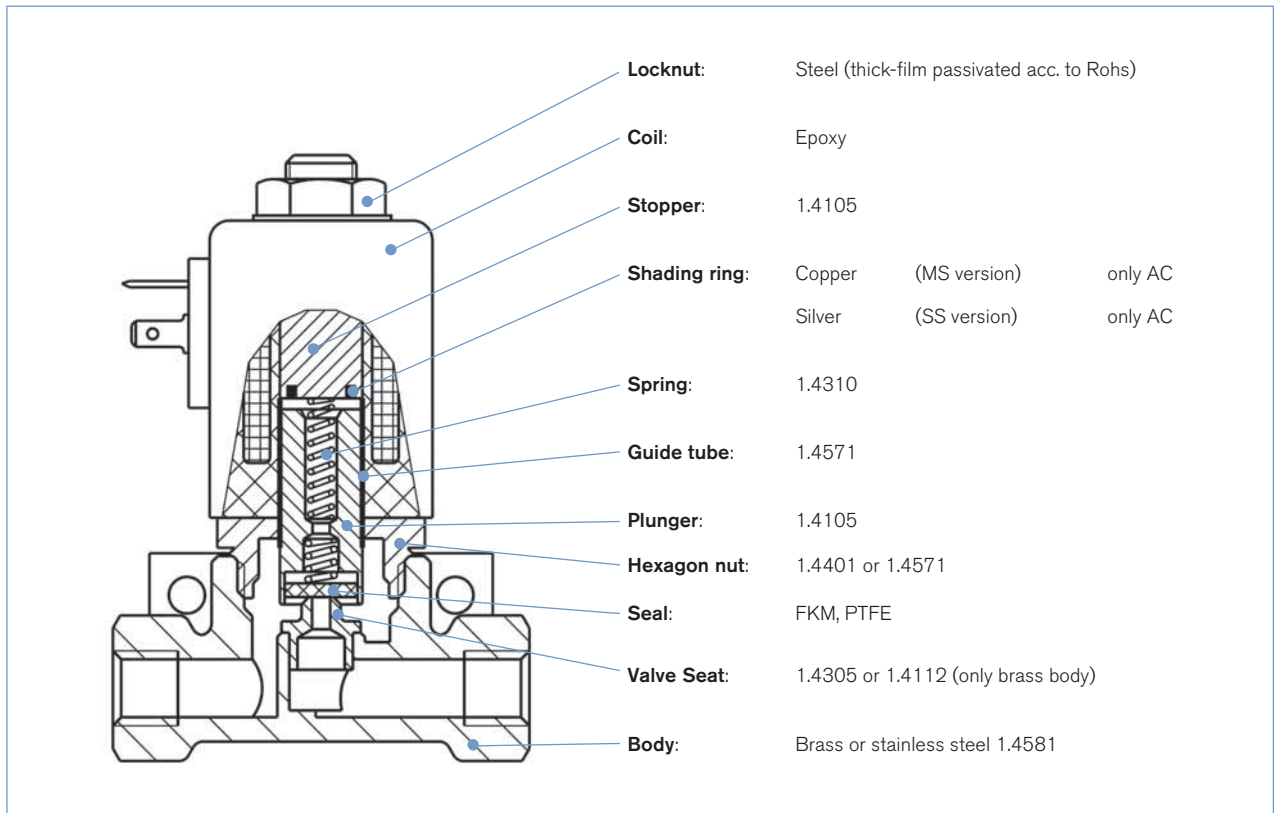

## Mounting set

- 2 M5 x 35 cheesehead screws
- 1 mounting bracket

Valve mounted using mounting kit  
Refer to the dimensional drawings for the valve

37 mm separation between the M5 threaded holes  
48 mm separation between the Ø7 bores

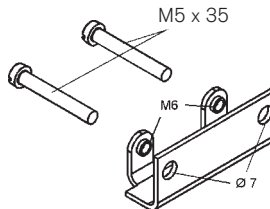

Item no. 151 287

(only for brass body versions)  
Mounting set for stainless steel versions on request

## Ordering chart for valves (other versions on request)

All valves with brass body and stainless steel seat or stainless steel body with cable plug included

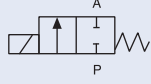
Circuit function	Port connection	Orifice [mm]	Kv value water <sup>1)</sup> [m <sup>3</sup> /h]	Pressure range [bar] <sup>2)</sup>			Seal material	Item no. per voltage/frequency [V/Hz]				
				DC for gases and liquids	AC for gases for liquids			024/DC	024/50	110/50	230/50	
<b>A</b>  2/2-way valve NC	<b>Brass body</b>											
	G 1/4	1.0	0.03	0-100	0-100	0-100	PTFE	058 360	020 755	–	067 692	
		2.0	0.12	0-20	0-60	0-35	FKM	089 888	020 033	020101	064 119	
		3.0	0.25	0-10	0-25	0-16	PTFE	052 872	058 421	058 888	046 865	
		4.0	0.5	0-4	0-12	0-10	PTFE	058 796	065 454	023 897	053 188	
		5.0	0.65	0-2	0-7	0-6	PTFE	020 164	049 194	049 830	050 879	
		5.0	0.65	0-2	0-7	0-6	FKM	–	–	–	052 424	
	G 3/8	4.0	0.5	0-4	0-12	0-10	PTFE	065 438	059 100	046 886	051 143	
		5.0	0.65	–	0-16	0-6	FKM	–	022 551	–	025 885	
		5.0	0.65	0-2	0-7	0-6	PTFE	020 664	057 644	023 581	050 880	
		6.0	0.8	0-1	0-5	0-4	PTFE	053 764	050 389	066 222	051 324	
	G 1/2 <sup>3)</sup>	4.0	0.5	0-4	0-12	0-10	PTFE	089 404	–	089 403	076 551	
		6.0	0.8	0-1	0-5	0-4	FKM	135 958	135 959	135 947	135 950	
	<b>Stainless steel body</b>											
	G 1/4 <sup>3)</sup>	1.0	0.03	0-100	0-100	0-100	PTFE	018 004	078 420	–	019 862	
		3.0	0.25	0-10	0-25	0-16	PTFE	021 554	018 593	–	061 010	
		4.0	0.5	0-4	0-12	0-10	PTFE	021 251	020 468	–	023 279	
		5.0	0.65	0-2	0-7	0-6	PTFE	125 097	019 991	086 924	025 250	
	G 1/2 <sup>3)</sup>	3.0	0.25	0-10	0-25	0-16	PTFE	019 204	059 254	–	055 506	
4.0		0.5	0-4	0-12	0-10	PTFE	065 684	066 932	–	054 473		
6.0		0.8	0-1	0-5	0-4	FKM	022 504	052 859	067 990	054 811		

<sup>1)</sup> Flow rate; Kv value water [m<sup>3</sup>/h] measured at +20°C, 1 bar pressure at valve inlet and free outlet

<sup>2)</sup> Pressure valves [bar]; gauge pressures with respect to the prevailing atmosphere pressure (the pressure rates for liquids are specified on the type plate)

<sup>3)</sup> All versions with mounting bracket included

### **i** Further versions on request



#### Approvals

UL, UR, CSA, ATEX, CGA/AGA



#### Temperature

High temperature version up to 250 °C



#### Materials

Seal material EPDM, NBR



#### Analytical

Silicon, oil and fat-free version for oxygen



#### Pressure

High performance version with high power electronic for higher pressures.

## Dimensions [mm]

## Stainless steel version

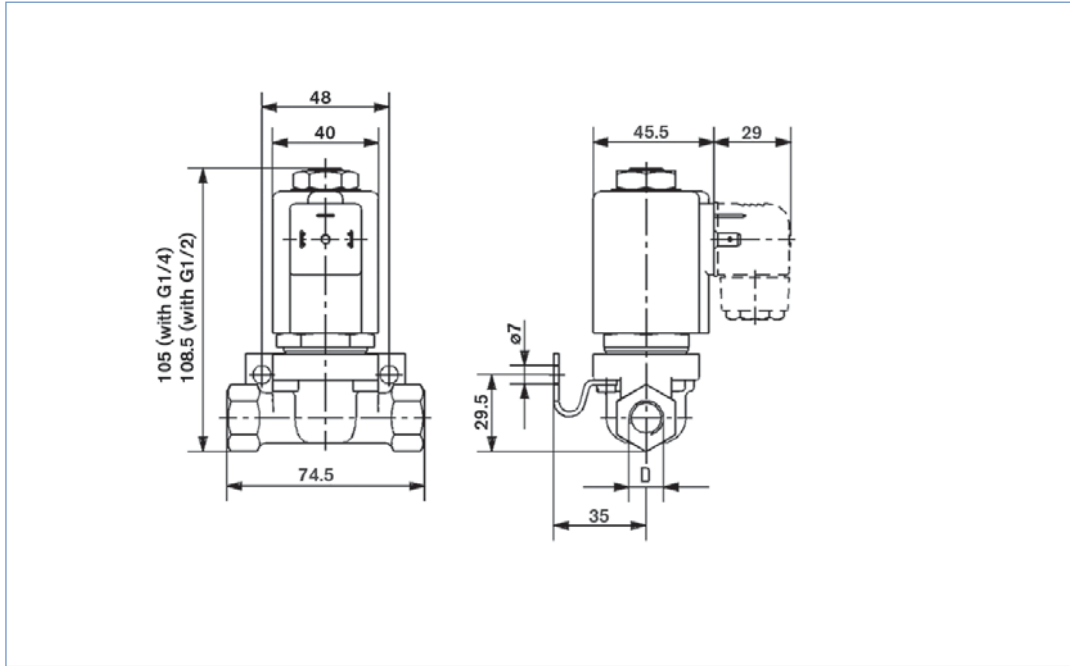

## Brass version

